



UNIVERSITY OF NOVI SAD
Technical faculty "Mihajlo Pupin"
Zrenjanin, Republic of Serbia

In cooperation with partners

*Industrial Engineering
and
Environmental Protection*

I I Z S
conference

PROCEEDINGS

**X International Conference –
Industrial Engineering And Environmental
Protection (IIZS 2020)**

Zrenjanin, 8-9th October 2020.



University of Novi Sad
Technical faculty “Mihajlo Pupin”
Zrenjanin, Republic of Serbia



X International Conference Industrial Engineering and Environmental Protection (IIZS 2020)

Proceedings

Zrenjanin, 8 – 9th October 2020.

IN COOPERATION WITH PARTNERS:

 <p>UP T Universitatea Politehnica Timișoara</p>	<p>UNIVERSITY POLITEHNICA TIMISOARA, FACULTY OF ENGINEERING, HUNEDOARA, ROMANIA</p>	
	<p>UNIVERSITY «St. KLIMENT OHRIDSKI», TECHNICAL FACULTY, BITOLA, MACEDONIA</p>	
	<p>„AUREL VLAICU” UNIVERSITY OF ARAD, FACULTY OF ENGINEERING, ARAD, ROMANIA</p>	
	<p>UNIVERSITY OF EAST SARAJEVO, FACULTY OF MECHANICAL ENGINEERING EAST SARAJEVO, REPUBLIC OF SRPSKA, B&H</p>	
	<p>UNIVERSITY OF GIRE SUN, FACULTY OF ENGINEERING, GIRE SUN, TURKEY</p>	

X International Conference - Industrial Engineering and Environmental Protection (IIZS 2020)

Organizer of the Conference:

Technical faculty "Mihajlo Pupin", Zrenjanin, University of Novi Sad, Republic of Serbia

Reviewers:

Ph. D Slavica Prvulovic, Technical faculty "Mihajlo Pupin", Zrenjanin, Republic of Serbia
Ph.D Bogdana Vujić, Technical faculty "Mihajlo Pupin", Zrenjanin, Republic of Serbia
Ph.D Eleonora Desnica, Technical faculty "Mihajlo Pupin", Zrenjanin, Republic of Serbia
Ph.D Ljiljana Radovanović, Technical faculty "Mihajlo Pupin", Zrenjanin, Republic of Serbia
Ph.D Jasmina Pekez, Technical faculty "Mihajlo Pupin", Zrenjanin, Republic of Serbia
Ph. D Vladimi Šinik, Technical faculty "Mihajlo Pupin", Zrenjanin, Republic of Serbia
Ph.D Višnja Mihajlović, Technical faculty "Mihajlo Pupin", Zrenjanin, Republic of Serbia
Ph.D Snežana Filip, Technical faculty "Mihajlo Pupin", Zrenjanin, Republic of Serbia

Publisher:

Technical faculty "Mihajlo Pupin", Zrenjanin, University of Novi Sad

For publisher:

Ph.D Dragica Radosav, Dean of Technical faculty "Mihajlo Pupin", Zrenjanin

Technical treatment:

MSc Mića Đurđev, Technical faculty "Mihajlo Pupin", Zrenjanin, Republic of Serbia
MSc Borivoj Novaković, Technical faculty "Mihajlo Pupin", Zrenjanin, Republic of Serbia
BSc Luka Đorđević, Technical faculty "Mihajlo Pupin", Zrenjanin, Republic of Serbia
MSc Ivan Palinkaš, Technical faculty "Mihajlo Pupin", Zrenjanin, Republic of Serbia

The Conference is supported by the Ministry of Education, Science and Technological Development, Republic of Serbia

ISBN: 978-86-7672-340-9

CIP - Каталогизacija u publikaciji
Biblioteka Maticе српске, Нови Сад

62:005.3(082)(0.034.4)
502/504(082)(0.034.4)

INTERNATIONAL Conference Industrial Engineering and Environmental Protection (10 ; 2020 ; Zrenjanin)

Proceedings [Elektronski izvor] / X International Conference Industrial Engineering and Environmental Protection (IIZS 2020), Zrenjanin, 8-9th October 2020. - Zrenjanin : Technical Faculty "Mihajlo Pupin", 2020. - 1 elektronski optički disk (CD-ROM) ; 12 cm

Nasl. sa naslovnog ekrana. - Bibliografija uz svaki rad.

ISBN 978-86-7672-340-9

a) Индустрijско инжењерство - Зборници б) Животна средина - Заштита - Зборници

COBISS.SR-ID 22384393

SCIENTIFIC COMMITTEE - TECHNICAL FACULTY „MIHAJLO PUPIN“

Ph.D Slavica Prvulović, Technical faculty "Mihajlo Pupin", Zrenjanin, Serbia
Ph.D Vjekoslav Sajfert, Technical faculty "Mihajlo Pupin", Zrenjanin, Serbia
Ph.D Ljiljana Radovanović, Technical faculty "Mihajlo Pupin", Zrenjanin, Serbia
Ph.D Bogdana Vujić, Technical faculty "Mihajlo Pupin", Zrenjanin, Serbia
Ph.D Eleonora Desnica, Technical faculty "Mihajlo Pupin", Zrenjanin, Serbia
Ph.D Vladimir Šinik, Tehnicki fakultet "Mihajlo Pupin", Zrenjanin, Serbia
Ph.D Nadežda Ljubojev, Technical faculty "Mihajlo Pupin", Zrenjanin, Serbia
Ph.D Jasmina Pekez, Technical faculty "Mihajlo Pupin", Zrenjanin, Serbia
Ph.D Snežana Filip, Technical faculty "Mihajlo Pupin", Zrenjanin, Serbia
Ph.D Višnja Mihajlović, Technical faculty "Mihajlo Pupin", Zrenjanin, Serbia

INTERNATIONAL SCIENTIFIC COMMITTEE

Ph.D James G. Speight, CD&W Inc., Laramie, Wyoming, USA
Ph.D Hosam E.A.F. Bayoumi Hamuda, Obuda Univerzity, Budapest, Hungary
Ph.D Svetlana Lilkova, University of Architecture, Civil Engineering and Geodesy (UACEG), Faculty of Hydraulic Engineering, Sofia, Bulgaria
Ph.D Dimitar G. Petrov, Technical University Sofia, branch Plovdiv, Bulgaria
Ph.D Valentina Emilia Balas, "Aurel Vlaicu" University of Arad, Faculty of Engineering, Arad, Romania
Ph.D Imre Kiss, University Politehnica Timisoara, Faculty of engineering, Hunedoara, Romania
Ph.D Francisc Popescu, University Politehnica Timisoara, Timisoara, Romania
Ph.D Mukrimin Şevket Guney, University of Giresun, Faculty of Engineering, Giresun, Turkey
Ph.D Mustaca Serkan Soylu, University of Giresun, Faculty of Engineering, Giresun, Turkey
Ph.D Yalçın Tepe, University of Giresun, Faculty of Engineering, Giresun, Turkey
Ph.D Mustafa Türkmen, University of Giresun, Faculty of Engineering, Giresun, Turkey
Ph.D Aysun Turkmen, University of Giresun, Faculty of Engineering, Giresun, Turkey
Ph.D Muharrem Hilmi Aksoy, Selcuk University, Engineering Faculty, Konya, Turkey
Ph.D Alexander Salnikov, Ukhta State Technical University (USTU), Ukhta, Republic of Komi, Russia
Ph.D Hrvoje Glavaš, Josip Juraj Strossmayer University of Osijek, Faculty of Electrical Engineering, Computer Science and Information Technology, Osijek, Croatia
Ph.D Tomislav Barić, Josip Juraj Strossmayer University of Osijek, Faculty of Electrical Engineering, Computer Science and Information Technology, Osijek, Croatia
Ph.D Mirko Karakašić, Josip Juraj Strossmayer University of Osijek, Faculty of Mechanical Engineering Slavonski Brod, Slavonski Brod, Croatia
Ph.D Vangelce Mitrevski, University «Sv. Kliment Ohridski», Technical Faculty, Bitola, Macedonia
Ph.D Tale Geramitcioski, University «Sv. Kliment Ohridski», Technical Faculty, Bitola, Macedonia
Ph.D Milija Kraišnik, University of East Sarajevo, Faculty of Mechanical Engineering, Republic of Srpska, Bosnia and Herzegovina
Ph.D Mirjana Vojinović Miloradov, professor emeritus, University of Novi Sad, Faculty of Technical Sciences, Novi Sad, Serbia
Ph.D Bratislav Blagojević, University of Niš, Faculty of Mechanical Engineering, Niš, Serbia
Ph.D Blaža Stojanović, University of Kragujevac, Faculty of Engineering, Kragujevac, Serbia
Ph.D Dragan D. Milanović, University of Belgrade, Faculty of Mechanical Engineering, Belgrade, Serbia
Ph.D Mijodrag Milošević, University of Novi Sad, Faculty of Technical Sciences, Novi Sad, Serbia
Ph.D Dejan Lukic, University of Novi Sad, Faculty of Technical Sciences, Novi Sad, Serbia
Ph.D Milan Rackov, University of Novi Sad, Faculty of Technical Sciences, Novi Sad, Serbia
Ph.D Snežana Dragicevic, University of Kragujevac, Faculty of Technical Sciences, Cacak, Serbia
Ph.D Jasmina Radosavljevic, University of Niš, Faculty of Occupational Safety, Niš, Serbia
Ph.D Amelija Đorđević, University of Niš, Faculty of Occupational Safety, Niš, Serbia
Ph.D Ivona Radovic, University of Belgrade, Faculty of Technology and Metallurgy, Belgrade, Serbia
Ph.D Mirjana Kijevcanin, University of Belgrade, Faculty of Technology and Metallurgy, Belgrade, Serbia
Ph.D Aleksandra Sretenovic, University of Belgrade, Faculty of Mechanical Engineering, Belgrade, Serbia
Ph.D Aleksandra Mihailovic, University of Novi Sad, Faculty of Technical Sciences, Novi Sad, Serbia
Ph.D Nebojša Ralevic, University of Novi Sad, Faculty of Technical Sciences, Novi Sad, Serbia

Ph.D Aleksandar Ašonja, University Business Academy in Novi Sad, Faculty of Economics and Engineering Management in Novi Sad, Serbia
Ph.D Marina Milovanovic, University "Union – Nikola Tesla", Faculty for entrepreneurial business and real estate management, Belgrade, Serbia
Ph.D Jasmina Perišić, University "Union – Nikola Tesla", Faculty for entrepreneurial business and real estate management, Belgrade, Serbia
Ph.D Jordana Ninkov, Senior Research Associate, Institute of Field and Vegetable Crops, Novi Sad, Serbia
Ph.D Tamara Ivetic, Senior Research Associate, University of Novi Sad, Faculty of Sciences, Department of Physics, Novi Sad, Serbia
Ph.D Marko Ristic, Research Associate, Institute Mihajlo Pupin, Belgrade, Serbia

Organizing Committee:

Ph.D Ljiljana Radovanović, Technical faculty "Mihajlo Pupin", Zrenjanin, Serbia

Ph.D Slavica Prvulović, Technical faculty "Mihajlo Pupin", Zrenjanin, Serbia

Ph.D Eleonora Desnica, Technical faculty "Mihajlo Pupin", Zrenjanin, Serbia

Ph.D Bogdana Vujić, President, Technical faculty "Mihajlo Pupin", Zrenjanin, Serbia

Ph.D Jasmina Pekez, Technical faculty "Mihajlo Pupin", Zrenjanin, Serbia

Ph.D Višnja Mihajlović, Technical faculty "Mihajlo Pupin", Zrenjanin, Serbia

Ph.D Vladimir Šinik, Tehnicki fakultet "Mihajlo Pupin", Zrenjanin, Serbia

Ph.D Snežana Filip, Technical faculty "Mihajlo Pupin", Zrenjanin, Serbia

Ph.D Zoran Čepić, Faculty of technical sciences, Novi Sad, Serbia

M.Sc Jasna Tolmac, Technical faculty "Mihajlo Pupin", Zrenjanin, Serbia

M.Sc Ivan Palinkaš, Technical faculty "Mihajlo Pupin", Zrenjanin, Serbia

M.Sc Una Marceta, Technical faculty "Mihajlo Pupin", Zrenjanin, Serbia

M.Sc Borivoj Novakovic, Technical faculty "Mihajlo Pupin", Zrenjanin, Serbia

M.Sc Mića Đurdev, Technical faculty "Mihajlo Pupin", Zrenjanin, Serbia

B.Sc Eleonora Terečik, Technical faculty "Mihajlo Pupin", Zrenjanin, Serbia

B.Sc Luka Đorđević, Technical faculty "Mihajlo Pupin", Zrenjanin, Serbia

Word of Thanks

We wish to thank Ministry of Education,
Science and Technological Development, Republic of Serbia,
for donated financial means which supported printing
the Conference Proceedings and organization of
X International Conference -
Industrial Engineering and Environmental Protection (IIZS 2020)

INTRODUCTION

Departments of Mechanical engineering and Department of Environmental protection of Technical Faculty "Mihajlo Pupin", Zrenjanin, has organized the X Anniversary International Conference «Industrial Engineering and Environmental Protection – IIZS 2020».

The topics of scientific conference «IIZS 2020», cover the fields of Industrial engineering and Environmental protection: Mechanical engineering, Energetics and process technique, Designing and maintenance, Oil and gas engineering, Health and environmental protection, Environmental management and Occupational safety.

The main goals of the conference are: innovation and expansion of knowledge engineers in industry and environmental protection; support to researchers in presenting the actual results of research projects, establishing new contacts with leading national and international institutions and universities; popularization of the faculty and its leading role in our society and the immediate environment, in order to attract quality young population for studying at our faculty, cooperation with other organizations, public companies and industry; initiative for collecting ideas in solving specific practical problems; interconnection and business contacts; introducing professional and business organizations with results of scientific and technical research; presentation of scientific knowledge and exchange of experiences in the field of industrial engineering.

We would like to express our gratitude to the partners of the conference – „Aurel Vlaicu” University of Arad, Faculty of engineering, Arad, Romania; University «St. Kliment Ohridski», Technical faculty, Bitola, Macedonia; University Politehnica Timisoara, Faculty of engineering, Hunedoara, Romania; University of East Sarajevo, Faculty of mechanical engineering East Sarajevo, B&H, Republic of Srpska; University of Giresun, Faculty of engineering, Giresun, Turkey for supporting the organization of the 10th Anniversary International Conference «IIZS 2020». We are also grateful to all the authors who have contributed with their works to the organization of the scientific meeting «IIZS 2020».

We would like to extend our special thanks to the Ministry of Education, Science and Technological Development, Republic of Serbia and the management of Technical Faculty «Mihajlo Pupin», University of Novi Sad, for supporting the organization of the Conference «IIZS 2020».

Since we are celebrating the 10th Anniversary of our Conference we are trying to keep the tradition of researchers meeting every year. We are open and thankful for all useful suggestions which could contribute that the next, XI International Conference - Industrial Engineering and Environmental Protection, become better in organizational and program sense.

Chairman of the Organizing Committee
Prof. Ph.D Ljiljana Radovanović

Zrenjanin, 8 - 9th October 2020.

Conference participants are from the following countries:



Serbia



Italy



Slovenia



Portugal



United States of America



Bulgaria



Romania



Canada



Turkey



Austria



Iran



Croatia



Hungary



Czech Republic



Germany



Bosnia and Herzegovina

CONTENTS

PLENARY SESSION

THE INFLUENCE OF THE ADSORBENT HYDRATION ON COBALT ADSORPTION FROM WATER SOLUTIONS (Jovan Jovanović, Ivana Milošević, Sanja Kurćubić, Milan Milivojević)	3
EXTRACTS OBTAINED BY NATURAL DEEP EUTECTIC SOLVENTS (NDESs) EXTRACTION AS POTENTIAL FUNCTIONAL FOOD ADDITIVES (Rada Pjanović, Predrag Petrović, Ana Milivojević, Danijela Šeremet, Draženka Komes)	11
INTERACTIONS OF CLIMATE CHANGE WITH FOOD SECURITY AND GOALS OF SUSTAINABLE DEVELOPMENT IN AGROECOSYSTEM (Hosam Bayoumi Hamuda)	17

I - INDUSTRIAL ENGINEERING

Session 1. Mechanical Engineering

DEVELOPMENT OF INNOVATIVE AND ENTREPRENEURIAL COMPETENCIES OF FUTURE ENGINEERS THROUGH THE ITlab PROJECT AT THE TECHNICAL FACULTY “MIHAJLO PUPIN” ZRENJANIN (Dragica Radosav, Eleonora Desnica, Slavica Prvulović, Ljiljana Radovanović, Jasmina Pekez, Vladimir Šinik, Ivan Palinkaš)	30
INDUSTRIAL ENGINEERING METHODS AND TECHNIQUES IN INDUSTRY 4.0 (Mirjana Misita, Vesna Spasojević Brkić, Dragan D. Milanović, Martina Perišić)	36
PROCEDURE DEVELOPMENT OF FLIP STATION FOR POSITING DISC AND ROTOR TYPE PARTS (Miroslav Milutinović, Spasoje Trifković, Aleksija Đurić)	42
MODERN SWARM-BASED ALGORITHMS FOR THE TENSION/COMPRESSION SPRING DESIGN OPTIMIZATION PROBLEM (Mića Đurđev, Eleonora Desnica, Jasmina Pekez, Milošević Mijodrag, Dejan Lukić, Borivoj Novaković, Luka Đorđević)	49
ANALYSIS OF CROSS-SECTION INFLUENCE ON EIGENFREQUENCIES OF THE CRANES WITH LOADING-UNLOADING TROLLEYS (Spasoje Trifković, Nebojša Radić, Miroslav Milutinović)	54
NUMERICAL INVESTIGATION OF THERMAL AND MECHANICAL BEHAVIOR OF WAFER MOLD (Omer Sinan Sahin, Muharrem Hilmi Aksoy, Abdullah Sadik Tazegul)	62
AUTOMATION AND INDUSTRY 4.0 (Stanko P. Stankov)	70

DYNAMIC MODELLING AND CONTROL OF A REACTION WHEEL INVERTED PENDULUM USING MSC ADAMS AND MATLAB (Abdullah Çakan, Ümit Önen)	78
FORGE WELDING OF BIMETALIC AXE (Zoran Karastojković, Nikola Bajić)	83
VOCATIONAL KNOWLEDGE TRANSFER OF CRAFT MASTER SKILLS IN POST INDUSTRIAL ERA (Vlad Walter Veckie, Edward Anthony Veckie).....	89
USING THE LASER SCANNING FOR CONSERVATION OF CULTURAL HERITAGE BUILDINGS (Clara-Beatrice Vilceanu, Luisa Dungan, Sorin Herban, Francisc Popescu)	98

Session 2. Energetics and Process Technique

MANUFACTURE OF THERMAL SOUND INSULATION PANELS FROM RASPBERRY AND BLACKBERRY CUTTINGS (Srećko Ćurčić, Sandra Milunović Koprivica, Milan Vesković)	106
GENERALIZED DIFFERENTIAL QUADRATURE METHOD FOR STUDYING THE IN-PLANE VIBRATIONS OF CURVED PIPES CONVEYING FLUID (Svetlana Lilkova-Markova, Dimitar Lolov).....	114
TECHNICAL AND TECHNOLOGICAL PARAMETER ANALYSIS OF HAMMER MILL CRUSHER (Slavica Prvulović, Jasna Tolmač, Milica Josimović, Vladimir Jakovljević, Aleksandra Božović)...	122
SMART AND NETWORKED VILLAGES - INFORMATION SYSTEM FOR RURAL DEVELOPMENT (Krešimir Lacković, Milan Ivanović).....	128
APPLICATION OF ORGANO-MINERAL AND MICROBIAL FERTILIZERS IN THE PROCESS OF RAISING RASPBERRIES (Srećko Curcic, Stevan Babic, Sandra Milunovic Koprivica, Momcilo Vujcic, Aleksandar Lepasovic)	137
OPTIMIZATION OF A SIMULATION FOR THERMOELECTRIC GENERATORS AND THEIR APPLICATION IN WATER BOILER SYSTEMS WITH COMBUSTION CHAMBER (Cristian Chirita, Momir Tabakovic).....	143
ALTERNATE FEEDSTOCKS IN THE REFINERY (James G. Speight, Ljiljana Radovanović)	152
MATHEMATICAL MODELS APPLIED FOR EXPERIMENTS ON BIOGAS PRODUCTION AT SMALL SCALE (Adrian Eugen Cioabla, Gabriela-Alina Dumitrel, Ana Maria Pană, Valentin Ordodi, Dorin Lelea, Mădălina Ivanovici, Francisc Popescu, Luisa Izabel Dungan).....	160

Session 3. Designing and maintenance

TEMPERATURE MAPPING IN PHARMACEUTICAL WAREHOUSE – FRAMEWORK FOR PHARMACY 4.0 (Ilija Tabašević, Dragan D. Milanović, Vesna Spasojevic Brkić, Mirjana Misita)	171
---	-----

CLUSTER AS A MODEL OF ENTREPRENEURIAL INFRASTRUCTURE (Vlado Medaković, Bogdan Marić).....	176
MATHEMATICAL MODEL OF OPTIMIZATION OF VIBRO-DIAGNOSTICS PROCEDURES (Milica Josimovic, Ljubisa Josimovic, Slavica Prvulovic, Vladimir Šinik).....	182
THE STUDY OF FACTORS AFFECTING THE QUALIFICATION OF PHARMACEUTICAL FACILITIES (Ilija Tabašević, Dragan D. Milanović).....	191
ON PID CONTROLLER DESIGN FOR A HIGH-ORDER SYSTEMS (Saša Lj. Prodanović, Ljubiša M. Dubonjić).....	199
CBM CONCEPT-PREDICTIVE MAINTENANCE-VIBRATION ANALYSIS AND BALANCING PROCESS OF INDUSTRIAL FANS (Borivoj Novaković, Ljiljana Radovanović, Rade Ivetić, Vladimir Šinik, Mića Đurđev, Luka Đorđević).....	208
BRIEF REVIEW OF THE APPLICATION OF THE SPM METHOD IN ORDER TO IMPROVE PREVENTIVE MAINTENANCE OF BEARINGS (Luka Djordjević, Borivoj Novaković, Jasmina Pekez, Ljiljana Radovanović, Mića Djurdjev)	214

Session 4. Oil and Gas Engineering

OIL PREPARATION AND HEATING FOR PIPELINE TRANSPORT (Jasna Tolmac, Slavica Prvulovic, Marija Nedic, Dragisa Tolmac, Vladimir Sinik).....	221
TESTING AND CONQUERING INTERVAL TECHNOLOGY ON THE WELL (Milan Marković, Zvonimir Bošković)	226
INCREASING THE QUALITY OF SEPARATION IN THE PHASE OF PREPARATION OF OIL FOR TRANSPORT (Milan Marković, Jasmina Perišić).....	232

II – ENVIRONMENTAL ENGINEERING

Session 5. Health and Environmental protection

CO ₂ EMISSION ASSESSMENT OF CONSTRUCTION AND WASTE MATERIALS IN THE CONTEXT OF CIRCULAR ECONOMY: CASE STUDY OF PROJECT “CORRIDOR X” (Nikola Karanović).....	244
ENVIRONMENTAL IMPACT ASSESSMENT FROM SMALL INCINERATION FACILITY OF ANIMAL CARCASS AND MATERIAL (Sandra Kozomora Subotin, Dejan Ubavin, Bojan Batinić, Zoran Čepić).....	250
FIRE RISKS IN A SMALL INCINERATION FACILITY OF ANIMAL CARCASS AND MATERIAL (Sandra Kozomora Subotin, Dejan Ubavin, Jelena Radonić, Zoran Čepić).....	257
EPOXICONAZOLE AND TEBUCONAZOLE ADSORPTION IN TWENTY DIFFERENT AGRICULTURAL SOILS IN RELATION TO THEIR PROPERTIES (Nikola Bošković, Kerstin Brandstätter-Scherr, Petr Sedláček, Zuzana Bílková, Lucie Bielská, Jakub Hofman)	265

EMISSION OF GREENHOUSE GASES FROM “BUBANJ” LANDFILL IN NIŠ (Jasmina Radosavljević, Amelija Đorđević, Ana Vukadinović, Lidija Milošević).....	273
EFFECTS OF SUNSPACE GEOMETRY ON THE ENERGY PROPERTIES OF DETACHED APARTMENT BUILDINGS (Ana Vukadinović, Jasmina Radosavljević).....	280
CAUSE-AND-EFFECT RELATIONSHIP BETWEEN CARBON MONOXIDE CONCENTRATIONS IN AMBIENT AIR AND RESPIRATORY DISEASES IN PRESCHOOL CHILDREN (Amelija Đorđević, Ana Miltojević, Aca Božilov, Goran Janačković).....	287
MODEL FOR QUANTIFICATION OF ENVIRONMENTAL IMPACT OF TEXTILE PRODUCTS WITHIN WEBSHOPS (Nemanja Stipić, Jürgen Seibold).....	294
SYNTHESIS AND IMMOBILIZATION OF ZnO NANOPARTICLES DOPED BY WO ₃ ON GLASS BED FOR DIAZINON REMOVAL FROM WATER (Afshin Maleki, Farzaneh Moradi, Reza Rezaee, Behzad Shahmoradi)	302
INFLUENCE OF MIXING INTENSITY ON ADSORPTION BEHAVIOUR OF ORGANIC POLLUTANTS ON MICROPLASTICS IN WATER (Maja Lončarski, Aleksandra Tubić, Sanja Vasiljević, Jasmina Agbaba).....	307
ARE WE AWARE OF MICROPLASTIC CONTENTS IN TOOTHPASTES? (Anja Bubik).....	313
WASTE LUBRICATING OILS, ENVIRONMENTAL IMPACT, RECYCLING AND STATE IN THE REPUBLIC OF SERBIA (Snežana Filip, Snežana Komatina).....	319
EXPERIMENTAL INVESTIGATION OF THE THERMAL DEGRADATION OF FOREST LITTER - PINE NEEDLES (Nikola Mišić, Milan Protić)	324
ANALYSIS OF SOUND LEVELS OF FOOD COURTS AND COFFEE HOUSES AT UNIVERSITY CAMPUS IN NOVI SAD (Selena Samardžić, Robert Lakatoš, Aleksandra Mihailović, Anja Ranković, Slavko Rakić, Savka Adamović, Dragan Adamović)	330
ASSESSMENT OF METHANE ENERGY RECOVERY POTENTIAL FROM THE MUNICIPAL SOLID WASTE LANDFILL OF ZRENJANIN (Una Marčeta, Bogdana Vujić, Višnja Mihajlović, Jelena Mičić)	335
IMPACT OF COVID-19 PANDEMIC CRISIS ON ENVIRONMENTAL PROTECTION EXPENDITURES OF LOCAL SELF GOVERNMENTS IN SERBIA (Nedeljko Ćurić).....	338
NO ₂ AQI ANALYSIS AS A MEASURE OF AIR POLLUTION REDUCTION IN THREE CITIES IN SERBIA, CAUSED BY THE QUARANTINE DUE TO THE COVID 19 PANDEMIC (Veselin Bežanović, Mladenka Novaković, Dušan Milovanović, Dragan Adamović)	346
IMPACTS OF ORGANIC WASTE MATERIALS ON SOIL CHARACTERIZATION (Hosam Bayoumi Hamuda, Katalin Hrustinszki, Ágnes Róczy, Mungunzaya Ganbat)	351

INFLUENCE OF CLIMATE CHANGE AND URBAN DEVELOPMENT ON GNSS MEASUREMENTS (Alina Bălă, Luisa Dungan, Clara-Beatrice Vîlceanu, Sorin Herban).....	360
ANALYSIS OF PHOTOVOLTAIC SOLAR PANEL EFFICIENCY (Marija Stankov, Nataša Dabić, Ivan Palinkaš, Dušanka Milanov)	366
PHARMACEUTICAL WASTE DISPOSAL PRACTICE AMONG THE CITIZENS IN THE MUNICIPALITY OF ZRENJANIN (Eleonora Terečik, Una Marčeta, Jelena Mičić, Višnja Mihajlović).....	374

Session 6. Environmental Management

AN APPLICATION OF DELPHI METHOD IN SELECTION OF HOSPITAL MANAGER (Ali Reza Afshari, Milan Nikolić).....	383
ENVIRONMENT PRESERVATION AND ACHIEVING COMPETITIVENESS WITHIN THE FRAMEWORKS OF SUSTAINABLE DEVELOPMENT (Mihalj Bakator, Dejan Đorđević, Ljiljana Đorđević, Srđan Bogetić, Dragan Čočkaló).....	390
THE CRUCIAL ROLE OF INNOVATION IN ACHIEVING COMPETITIVENESS OF DOMESTIC ENTERPRISES (Dragan Čočkaló, Mihalj Bakator, Dejan Đorđević, Cariša Bešić, Sanja Stanisavljev)	396
EMPLOYEES' PERCEPTION OF ENERGY CONSUMPTION AND ENVIRONMENTAL PROTECTION (Ivana Dolga, Ladin Gostimirović, Aleksandra Mihailović, Nebojša M. Ralević)	402
LANDSCAPE CHANGE SURVEY IN THE GÖDÖLLŐ HILLS BASED ON HISTORICAL MAPS (Krisztina Demény)	409

Session 7. Occupational Safety

FIRE IN INDUSTRIAL FACILITIES FROM THE ASPECTS OF FACILITY SAFETY AND EMPLOYEES HEALTH (Goran Bošković, Dejan Ubavin, Milana Ilić Mićunović, Zoran Čepić)	417
CONTRIBUTION TO THE SAFETY ANALYSIS DURING OPERATION WITH TRUCK-MOUNTED CRANE (Goran Bošković, Dejan Ubavin, Dragan Adamović, Zoran Čepić).....	422
AN APPROACH FORWARD TO DIGITALIZATION OF WORKPLACE RISK ASSESSMENT AND MONITORING (Mirjana Misita, Vesna Spasojević-Brkić, Martina Perišić, Marija Milanović, Ankica Borota-Tišma).....	427
GEOMETRIC CHARACTERISTICS OF PM PARTICLES TESTED WITH JMICROVISION SOFTWARE (Milana Ilić Mićunović, Zoran Čepić, Boris Agarski, Zorica Miroslavljević, Željko Santoši).....	434
THE EFFECTS OF ECONOMIC TRENDS AND SAFETY REGULATIONS ON OCCUPATIONAL INJURIES (Goran Janačković, Ivan Radojković, Amelija Đorđević, Jasmina Radosavljević, Dejan Vasović)....	441

PRELIMINARY DESIGN CALCULATIONS OF A SMALL WIND GENERATOR FOR THE SURROUNDINGS OF TOWN OF ZRENJANIN (Dimitar Petrov).....	447
EUROPEAN ONGOING INITIATIVES FOR TRANSFORMING COVID19 CRISIS INTO AN OPPORTUNITY FOR A SUSTAINABLE FUTURE (Kaja Primorac, Lucija Kolar, Anja Bubik, Daniela Tulone).....	457

Plenary Session

THE INFLUENCE OF THE ADSORBENT HYDRATION ON COBALT ADSORPTION FROM WATER SOLUTIONS

Jovan Jovanović¹, Ivana Milošević¹, Sanja Kurćubić¹, Milan Milivojević¹

¹University of Belgrade, Faculty of Technology and Metallurgy, Belgrade, Serbia

e-mail: iwanamiloshevic@gmail.com

Abstract: In this paper, adsorption of cobalt (II) ions from aqueous solutions was investigated, using Ca-alginate particles and composite made from Ca-alginate and hemp fibers with different degree of hydration in order to determine kinetics and adsorption isotherms for this processes. The concentrations of cobalt were monitored using atomic absorption spectrophotometry (AAS). Based on the experimental results, kinetic parameters and the coefficients for Langmuir and Freundlich adsorption isotherms were obtained. The obtained results showed that pretreatment had relatively high impact on cobalt adsorption and that investigated materials can provide a reduction of cobalt (II) ions concentration in wastewater in a cost-effective and efficient manner.

Key words: cobalt, adsorption, alginate beads, alginate-hemp fiber composite

INTRODUCTION

Clear water is essential for preservation of life on Earth. However, intensive industrial development has led to increased water pollution making it one of the greatest problems facing humanity today [1]. Some of the most common and most dangerous water pollutants are heavy metals. These are very toxic, non-degradable substances that must be removed from water in order to preserve its natural composition.

Cobalt is silver-gray, shiny, ductile and magnetic hard metal which chemical properties are very similar to nickel and iron [2, 3, 4]. The most common oxidation states of cobalt are +2 (cobaltous) and +3 (cobaltic) [3, 4]. Cobalt is rarely found in nature - there are traces of cobalt in Earth's crust and in mineral ores. In small amounts cobalt is necessary for normal functioning of human body since it is important constituent of vitamin B12. On the other hand, exposure to larger concentration of cobalt may indicate some serious health issues like cardiomyopathy, occupational contact dermatitis, chronic thyroiditis, polycythemia, etc. Since cobalt is widely used in industrial processes, its concentration in human environment including water is rising [2]. Therefore, removal of this element from industrial wastewater is necessary in order to prevent possible adverse effects of cobalt exposure on humans.

Over the years, many technologies for water purification from heavy metals have been developed. Commonly used methods include chemical precipitation, membrane separation, electroflotation, ion exchange, reverse osmosis and adsorption [5]. Adsorption stands out among listed methods for its flexibility and simple application. Cost of adsorption can be reduced by using easily available, low-cost materials such as biosorbents [1].

In this study the adsorption of cobalt ions from aqueous solutions using Ca-alginate and Ca-alginate-hemp fiber composite in different hydration condition was investigated.

THEORY

Alginates

Alginates are natural, linear, anionic, water-soluble polysaccharides which can be isolated from cell wall of brown algae. These are complex compounds which consist of α -L-guluronic acid and β -D-manuronic acid blocks (G and M block respectively) linked by 1,4-glycosidic bonds. Number and arrangement of these bounds have great impact on alginate properties. Alginate gels contain functional groups (carboxylic and hydroxyl) which represents active sites for metal ion binding hence they can be used as adsorbents. Due to their properties like low toxicity, biocompatibility, relatively low prices and simply gelation, alginates are increasingly used for adsorption of heavy metal ions from water [6].

Hemp fibers

Hemp has a great potential in removal of heavy metals from water due to its large biomass, low costs and easy growing. As well as alginates, hemp fibers contain different functional groups in its structure which allow them to bind metal ions from liquid. Content and position of these functional groups have significant influence on adsorption capacity of hemp fibers. Structure of hemp fibers can be modified in order to improve its adsorption ability [7, 8].

Adsorption kinetics

In order to understand and/or design adsorption process, knowledge of adsorption kinetic is required. There are many mathematical models that describe adsorption kinetic. Some of the models that are commonly used for this purpose are pseudo-first order model, pseudo-second order model and Weber-Moriss model [9].

Pseudo-first order model assumes that adsorption process follows first-order mechanism [9]. Linear form of pseudo-first model is given by following expression:

$$\ln(q_e - q_t) = \ln q_e + k_1 t \quad (1)$$

where q_e is equilibrium adsorption capacity in mg/g, q_t is adsorption capacity at time t in mg/g, k_1 is pseudo-first rate constant in min^{-1} and t is time in min.

According to pseudo-second order model, adsorption is proportional to the available adsorption sites on the surface of the adsorbent and process can be described by pseudo-second mechanism [9].

Linear form of pseudo-second model is given by following equation:

$$\frac{q_t}{t} = k_2 q_e^2 - k_2 q_e q_t \quad (2)$$

where k_2 is pseudo-second order rate constant.

Weber-Moriss model takes into account that adsorption is complex process which contains of film diffusion, surface diffusion and pore diffusion. It gives ability to determine which of these processes is the slowest and therefore limit the overall rate of the process [9].

Weber-Moriss model is defined as:

$$q_t = K_p \sqrt{t} + C \quad (3)$$

where K_p is rate constant in $\text{mg}/(\text{g} \cdot \text{min}^{0.5})$ and C is boundary layer thickness.

Adsorption isotherms

Adsorption isotherms are mathematical expressions that give connection between amount of adsorbate attached on a surface of adsorbent and equilibrium concentration of adsorbate [10]. There are many different adsorption isotherms models among which the most famous are Langmuir and Freundlich isotherm.

Langmuir isotherm is based on assumptions that adsorbent surface consists of equal adsorption sites which can bind only one adsorbate molecule.

Linear form of Langmuir isotherm is given by equation:

$$\frac{c_e}{q_e} = \frac{1}{K_L} + \frac{a_L}{K_L} c_e \quad (4)$$

where c_e is equilibrium concentration of adsorbate in solution in mg/dm^3 , K_L is adsorption equilibrium constant in dm^3/g and a_L is Langmuir constant connected with adsorption energy in dm^3/mg .

Freundlich isotherm describes adsorption on heterogeneous adsorbent surface [11].

Linear form of Freundlich isotherm is given by equation:

$$\ln q_e = \ln K_F + \frac{1}{n} \ln c_e \quad (5)$$

where K_F is adsorption constant in $(\text{mg/g})(\text{dm}^3/\text{mg})^{1/n}$, and $1/n$ is adsorption intensity.

EXPERIMENTAL

The experiments were conducted using: extract of brown algae in a powder form, cobalt-chloride ($\text{CoCl}_2 \cdot 6\text{H}_2\text{O}$), calcium-chloride ($\text{CaCl}_2 \cdot 2\text{H}_2\text{O}$), industrial hemp fibers and distilled water. Preparation of a standard 500 ppm cobalt-chloride solution, an alginate solution, alginate particles and an alginate-hemp fiber composite was performed.

- Standard 500 ppm solution of cobalt-chloride was made by dissolving 0,505 g of $\text{CoCl}_2 \cdot 6\text{H}_2\text{O}$ in 250 ml of distilled water. Working solutions of different concentrations (10, 20, 30, 50 and 75 ppm) were obtained by adding appropriate amount of standard cobalt-chloride solution in 50 ml of distilled water.
- Alginate solution was prepared by dissolving 1 g of brown algae powder in 50 ml of distilled water. This solution was later used to obtain alginate particles and alginate-hemp fiber composite.
- Alginate particles were made by instilling 2% alginate solution in 2% calcium-chloride solution in distilled water. Particles were submerged in solution for 24 hours. Thereafter, they were rinsed with distilled water and left in it for another 24 hours. Three sets of particles with different degree of hydration were made - dry particles, rehydrated particles and fresh particles. First set of particles (dry particles) was dried at 60 °C for 24 hours. Second set of particles (rehydrated particles) was rehydrated in distilled water for 24 hours after drying. Third set of particles (fresh particles) was inserted in cobalt solution without drying.
- In order to obtain alginate-hemp fiber composite, hemp fibers were immersed for 24 hours in each of following liquids respectively: alginate solution, calcium-chloride solution and distilled water. As well as particles, composite were made in three forms - dry composite, rehydrated composite and fresh composite. Dry composite was obtained by drying treated fibers at 60 °C for 24 hours. Rehydrated composite was obtained by rehydrating treated fibers in distilled water for 24 hours. Remaining treated fibers were submerged in cobalt solution and it represents fresh composite.

Convenience of every set of alginate particles and alginate-hemp fiber composite for adsorption of cobalt from aqueous solutions was tested. During the experiments, samples of these solutions were taken at 3, 5, 7, 10, 15, 30, 60, 120 and 300 minutes and the cobalt concentration in them was measured.

RESULTS AND DISCUSSION

Adsorption capacity as a function of contact time

Adsorption capacity (q_t) presents amount of adsorbate which is adsorbed per unit mass of adsorbent and is given by the following equation:

$$q_t = \frac{(c_0 - c_t)V}{m} \quad (6)$$

where c_0 is the initial concentration of cobalt in mg/dm^3 , c_t is the concentration of cobalt at time t in mg/dm^3 , m is the mass of the adsorbent in g and V is the volume of the solution in dm^3 .

Time-dependence of adsorption capacity for all investigated adsorbents is shown in Figure 1. The tests were performed on the 50 ppm working solution.

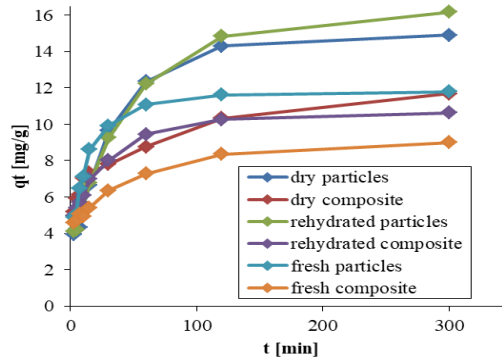

Fig. 1. The adsorption capacity vs. time, for $c_0=50$ ppm Co(II) ions, at 250 rpm, and 25 °C.

As can be seen in Figure 1, in almost all cases observed, equilibrium was established after ~ 120 min. Rehydrated particles have been showed to have the greatest adsorption potential, while adsorption potential of fresh composite is the lowest.

Values of equilibrium adsorption capacities (measured after 24h) are given in Table 1.

Table 1. The equilibrium sorption capacity, for $c_0 = 50$ ppm Co(II) ions, at 250 rpm, and 25 °C

Adsorbent	Dry particles	Dry composite	Rehydrated particles	Rehydrated composite	Fresh particles	Fresh composite
$q_{e,exp}$ (mg/g)	14.31	10.34	14.85	10.26	11.61	8.35

As it can be seen, using alginate particles as an adsorbent always gives a better result compared to composite, which is expected as alginate have bigger adsorption capacity than hemp fibers [12]. As for the particles, the best results were obtained using the one which were rehydrated. On the other hand, dry composite proved to be the best of the examined composite sets. As it can be seen in all cases the drying has positive effect on adsorption capacity probably due to the cracks in adsorbent structure that enable easier diffusion of adsorbate inside the adsorbent.

Results obtained for initial concentration of 75 ppm of cobalt-chloride where compared with results obtained for adsorption of cadmium (II) ions using same adsorbents [13]. In both cases better result were obtained using alginate particles, while the fresh adsorbents have the lowest adsorption potential. Furthermore, values of adsorption capacity are lower for cobalt (II) comparing to cadmium (II) ions.

Adsorption capacity as a function of initial concentration of cobalt in solution

Defining the dependence of the adsorption capacity on the initial concentration of adsorbate enables the construction of adsorption isotherms that are crucial for the analysis of the adsorption process.

Within this paper, examination of five solutions with cobalt concentrations of 10, 20, 30, 50 and 75 were performed. Results are presented in Figure 2.

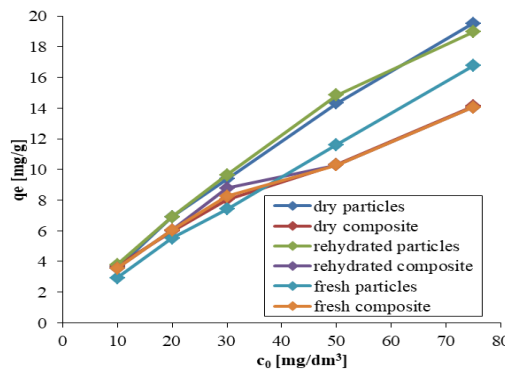

Fig. 2. The adsorption capacity vs. initial concentration of cobalt, at 250 rpm, and 25 °C.

Figure 2 shows that as initial concentration of cobalt in solution increases, so does the adsorption capacity. This graph also confirms previously presented conclusion that particles give better results than composite in the same condition.

Adsorption efficiency

Adsorption efficiency is obtained by following equation:

$$R [\%] = \frac{c_0 - c_e}{c_0} 100 \quad (7)$$

Dependence of adsorption efficiency on contact time for tested adsorbents obtained by experiments on 50 ppm working solution is presented in Figure 3.

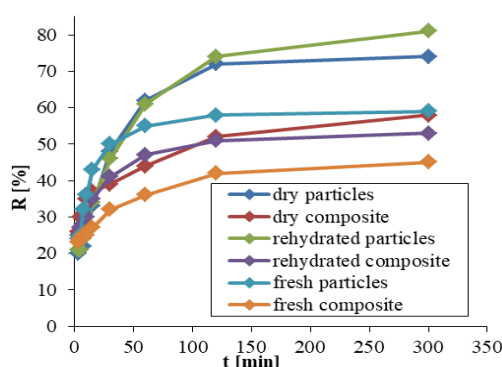

Fig. 3. The adsorption efficiency vs. time, for $c_0=50$ ppm Co(II) ions, at 250 rpm, and 25 °C

As it can be seen, the highest adsorption efficiencies are shown by dry and rehydrated particles. Using these adsorbents, after 120 minutes adsorption of about 70 - 80 % of cobalt ions was achieved. For the same time, about 60 % of cobalt ions were adsorbed on fresh particles. As for the composite, efficiency is somewhat lower. All sets of composite achieve adsorption of about 60 - 70 % of cobalt ions. It is also shown that the adsorption process on composite is slower compared to the process that takes place on the particles.

Adsorption kinetics

The adsorption kinetics of cobalt (II) ions on alginate particles and alginate-hemp fiber composite were examined using pseudo-first order and pseudo-second order kinetic model.

Results obtained for rehydrated particles are presented in Figures 4 as example, while results obtained for all of examined adsorbents are shown in Table 2. Tests were performed on 50 ppm working solution.

Table 2. The obtained parameters for pseudo-first order and pseudo-second-order kinetic model

Kinetic model	Parameter	Dry particles	Dry composite	Rehydrated particles	Rehydrated composite	Fresh particles	Fresh composite
Pseudo-first order	K_1 (min^{-1})	-0.0093	-0.0115	-0.0091	-0.0111	-0.0112	-0.0079
	q_e (mg/g)	9.488	6.007	11.36	4.54	4.319	4.384
	R^2	0.82	0.96	0.91	0.88	0.74	0.93
Pseudo-second order	K_2 (min^{-1})	0.0039	0.0084	0.003	0.0128	0.0142	0.0124
	q_e (mg/g)	15.75	11.86	17.12	10.87	12.05	9.174
	R^2	0.99	0.99	0.99	0.99	0.99	0.99

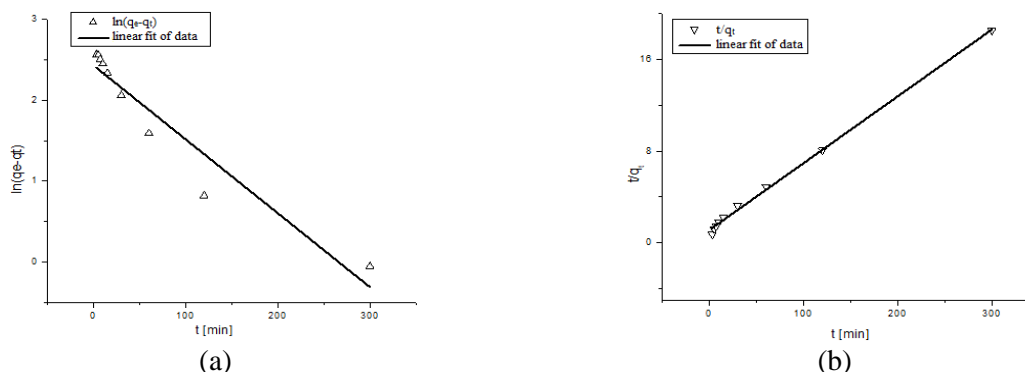

Fig. 4. The kinetics of Co(II) adsorption on rehydrated particles for $c_0=50$ ppm at 250 rpm, and 25 °C; (a) pseudo-first order, (b) pseudo-second order

Values of R^2 is closer to unity for pseudo-second model than for pseudo-first model which indicates that adsorption of cobalt (II) ions on investigated adsorbents is better described by pseudo-second kinetic model. Also, values of adsorption capacity calculated based on pseudo-second model are closer to the experimentally determined ones.

The kinetics of cobalt (II) ions adsorption on alginate particles and alginate-hemp fiber composite were also investigated by Weber-Moriss kinetic model. Results obtained for rehydrated particles are shown in Figure 5, while parameters of this model for different adsorbents are shown in Table 3.

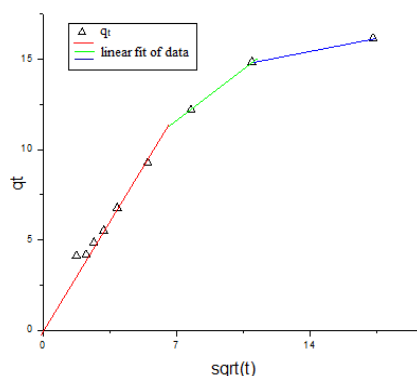

Fig. 5. The kinetics of Co(II) adsorption on rehydrated particles described with Weber-Moriss kinetic model for $c_0=50$ ppm at 250 rpm, and 25 °C

Table 3. The obtained parameters for Weber-Moriss kinetic model

Kinetic model	Parameter	Dry particles	Dry composite	Rehydrated particles	Rehydrated composite	Fresh particles	Fresh composite
Weber-Moriss model	K_{id1} (mg/g min ^{1/2})	0.079	0.214	0.19	0.053	0.024	0.105
	K_{id2} (mg/g min ^{1/2})	1.38	0.41	0.8	0.55	0.3	0.49
	K_{id3} (mg/g min ^{1/2})	-	0.97	1.71	1.02	1.46	-

Presented results show that dependence of adsorption on contact time for all tested adsorbents is multi-linear. This indicates that process of adsorption consists of several stages, namely that intraparticle diffusion isn't dominant mechanism.

Adsorption equilibrium

The equilibrium of cobalt (II) ions adsorption on different adsorbents was tested using Langmuir and Freundlich isotherms. Figure 6 presents results obtained for rehydrated particles, while results obtained for all investigated adsorbents are summarized in Table 4.

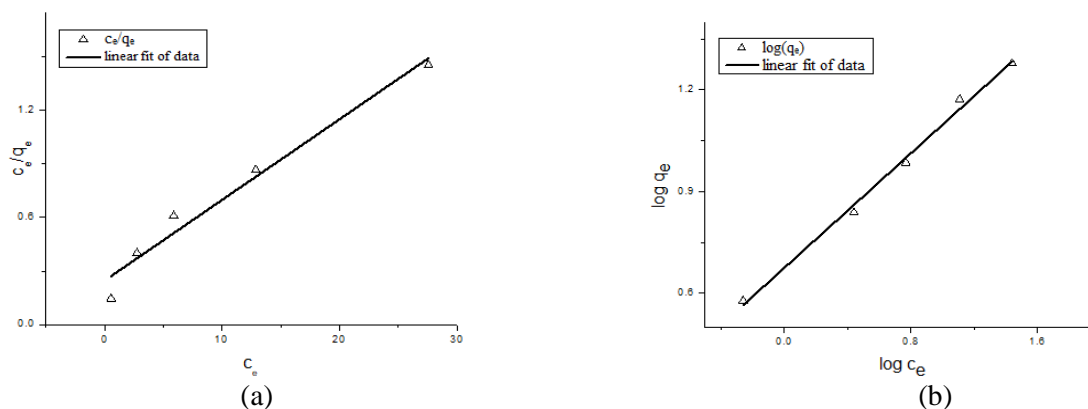

Fig. 6. The adsorption isotherm for Co(II) adsorption on rehydrated particles for $c_0=50$ ppm at 250 rpm, and 25 °C; (a) Langmuir, (b) Freundlich

Table 4. The obtained parameters for Langmuir and Freundlich isotherm

Adsorption isotherm	Parameters	Dry particles	Dry composite	Rehydrated particles	Rehydrated composite	Fresh particles	Fresh composite
Langmuir	K_L (min^{-1})	0.123	0.146	0.183	0.158	0.036	0.053
	q_m (mg/g)	24.39	15.31	22.17	15.15	28.91	16.67
	R^2	0.95	0.92	0.96	0.94	0.85	0.14
Freundlich	K_f (mg g^{-1}) ($\text{dm}^3 \text{mg}^{-1}$) $^{1/n}$	7,362	3,837	4,721	3,499	1,535	2,897
	n (g/dm^3)	3,425	3,058	2,364	2,703	1,488	2,849
	R^2	0.90	0.97	0.99	0.96	0.99	0.23

Higher values of R^2 obtained by fitting experimental data with Freundlich isotherm point out that this isotherm better represent equilibrium of cobalt (II) ions adsorption on investigated adsorbents than Langmuir isotherm except for dry particles. Since Freundlich isotherm is defined to describe heterogeneous adsorption, obtained results confirm that adsorption of cobalt (II) ions is multistage process as kinetic study already showed. However, R^2 coefficients for fresh composite obtained using both, Langmuir and Freundlich isotherm, are very low which suggests that these models don't describe equilibrium of adsorption of cobalt (II) ions on this adsorbent well and that another model has to be applied.

CONCLUSION

Based on the performed experiments, the obtained results and the presented discussion, the following may be concluded:

- The hydration condition of used adsorbent has evident impact on the adsorption process but further investigation is necessary in order to determine nature and reasons of this impact.
- Alginate particles showed higher adsorption capacity than alginate-hemp fiber composite.
- Adsorption kinetics of Co(II)-ions on investigated adsorbents can be presented with pseudo-second order kinetic model. Since rate-limiting process for the pseudo-second order process is diffusion (physical process) and for the pseudo-first order chemical reaction (chemical process), it may be concluded that tested adsorbents have good mass transfer properties, namely that their surface is easily available for adsorption.
- The examined adsorption process is well described by multistage diffusion model which indicates complex structure of adsorbents.

- The equilibrium of adsorption of Co(II)-ions can be described with Freundlich isotherm, which indicate the heterogeneity of the adsorbents surfaces and multistage adsorption.

REFERENCES

- [1] Milojković, J., Mihajlović, M., Šošarić, T., Lopičić, Z., Petrović, M., Lačnjevac, Č., Stojanović, M., Investigation of efficiency of different sorption materials for Cu(II) removal from aqueous solution, *Zaštita materijala*, Vol. 55, pp, 281-286, 2014
- [2] Barceloux, D. G., Cobalt, *Clin. Toxicol.*, Vol. 37, pp, 201-216, 1999.
- [3] Leyssens, L., Vinck, B., Van Der Straeten, C., Wuyts, F., Maes, L., Cobalt toxicity in humans. A review of the potential sources and systematic health effects, *Toxicology*, Vol. 387, pp, 43-56, 2017.
- [4] Paustenbach, D. J., Tvermoes, B. E., Unice, K. M., Finely, B. L., Kerger, B. D., A review of the health hazards posed by cobalt, *Crit. Rev. Toxicol.*, Vol. 43, pp, 316-362, 2013.
- [5] Asçi, Y., Kaya, S., Removal of cobalt ions from water by ion-exchange method, *Desalin. Water Treat.*, Vol. 52, pp, 267-273, 2014.
- [6] Milivojevic, M., Pajic-Lijakovic, I., Levic, S., Nedovic, V., Bugarski, B., Alginic Acid: Sources, Modifications and Main Applications, In: Moore, A., ed. *Alginic Acid - Chemical Structure, Uses and Health Benefits*, New York, Nova Science Publishers, Inc., Chapter 3, pp, 45-88, 2015.
- [7] Pejic, B., Vukcevic, M., Kostic, M., Skundric, P., Biosorption of heavy metal ions from aqueous solutions by short hemp fibers: Effect of chemical composition, *Journal of Hazardous Materials*, Vol.164, pp. 146-153, 2009.
- [8] Vukčević, M., Pejić, B., Laušević, M., Pajic-Lijakovic, I., Kostić, M., Influence of chemically modified short hemp fiber structure on biosorption process of Zn²⁺ ions from waste water, *Fiber Polymers*, Vol.15, pp, 687-697, 2014.
- [9] Kajjumba, G. W., Emik, S., Öngen, A., Özcan, H. K., Aydin, S., Modelling of Adsorption Kinetic Processes - Errors, Theory and Application, In: *Advanced Sorption Process Applications*, IntechOpen Limited, 2018.
- [10] Latour, R. A., The Langmuir isotherm: A commonly applied but misleading approach for the analysis of protein adsorption behavior, *J. Biomed. Mater. Res.*, Vol. 103, pp, 949-958, 2014.
- [11] Ayawei, N., Ebelegi, A. N., Wankasi, D., Modeling and Interpretation of Adsorption Isotherms, *J. Chem.*, Vol. 2017, pp, 1-11, 2017.
- [12] Milivojević M., Pejić B., Vukčević M., Kostić M., Novi biosorbent na bazi vlakna konoplje (*Cannabis sativa*) i *Ca-alginata* za uklanjanje jona olova i cinka, *Zaštita Materijala*, Vol. 59, pp, 67-76, 2018.
- [13] M. Milivojević, M., Devrnja, D., Antanasković, I., Jovanović, J., Kijevčanin, M., The impact of the adsorbent hydration on the cadmium adsorption from water solutions, VIII International Conference Industrial Engineering and Environmental Protection, October 11-12th, Zrenjanin, Serbia, pp, 19-26, 2018.

EXTRACTS OBTAINED BY NATURAL DEEP EUTECTIC SOLVENTS (NDESs) EXTRACTION AS POTENTIAL FUNCTIONAL FOOD ADDITIVES

Rada Pjanović¹, Predrag Petrović², Ana Milivojević²,
Danijela Šeremet³, Draženka Komes³

¹University of Belgrade, Faculty of Technology and Metallurgy, Belgrade, Serbia

²University of Belgrade, Innovation Centre, Faculty of Technology and Metallurgy,
Belgrade, Serbia

³University of Zagreb, Faculty of Food Technology and Biotechnology, Zagreb, Croatia

e-mail: rada@tmf.bg.ac.rs

Abstract: Due to the continuous demand of green extraction procedures, Natural Deep Eutectic Solvents (NDESs) have arisen in the last years as new green solvents alternative to the conventional organic ones. Compared with conventional organic solvents, NDESs are eco-friendly, biodegradable and non-toxic organic compounds which are also a low cost, being easy to produce in the laboratory. The aim of this paper is to give overview of NDESs extraction and to develop an extraction method for lemon balm (*Melissa officinalis*) polyphenolic compounds. From a preliminary screening of 5 different natural deep eutectic solvents combination of betaine and sucrose was selected. The effect of water in eutectic mixture was investigated using selected mixture. The best results were obtained with 50 % w/w water added to eutectic mixture.

Key words: extraction, natural deep eutectic solvents, lemon balm

INTRODUCTION

The development of new extraction techniques that exclude hazardous solvents and that are sustainable has been the subject of increasing research interest in recent years. More than fifty review papers dedicated to the application of natural deep eutectic solvents (NDESs) in various fields of science, research and technology (production of new materials, nanotechnology, biotechnology and bioengineering, the extraction and separation of natural products, liquid-liquid microextraction etc.) have been published in last five years, [1].

Ideal solvents should be non-volatile (reduced air pollution), non-flammable (process safety), stable (easier recycling and reuse) and based on renewable sources. NDESs are able to fully address all these requirements, [2]. Deep eutectic solvents (DESs) are defined as a mixture of two or more components, which may be solid or liquid and that at a particular composition the melting points of DESs are significantly lower than the melting points of their individual components. NDESs are a mixture of two or three components that form intramolecular hydrogen bonds; hydrogen bond acceptors usually are organicsalts (quaternary ammonium or phosphonium salt), while hydrogen bond donors could be: sugar, alcohol, amino acid, organic acid etc. In some cases, water could be added to the eutectic mixture. Since it is possible to use many different components to obtain the eutectic mixtures, it is possible to obtain a solvent with particular physicochemical properties and selectivity. NDESs are regarded to have good solubility for many components, including drugs, metal oxides, and carbon dioxide. Because of mentioned properties NDESs are very interesting as potential green solvents in many fields, including the extraction of biologically active compounds from plant materials, [2-4].

One of the most important compounds in the plants are polyphenols. Polyphenols offering various health benefits. Regularly consuming polyphenols is considered to boost digestion and brain health, as well as protect against heart disease, type 2 diabetes, and even certain cancers. Most of their health benefits are related to antioxidant activity they possess. More than 8,000 types of polyphenols have been identified. They can be categorized into 4 main groups:

- Flavonoids (60% of all polyphenols). Examples include quercetin, catechins, and anthocyanins, which are found in foods like apples, onions, dark chocolate, and red cabbage.
- Phenolic acids (30% of all polyphenols). Examples include hydroxybenzoic and hydroxycinnamic acids and their derivatives, which are mostly found in fruits, vegetables, whole grains, and seeds.

- Polyphenolic amides. This category includes capsaicinoids in chili peppers and avenanthramides in oats.
- Other polyphenols. This group includes resveratrol in red wine, ellagic acid in berries, curcumin in turmeric, and lignans in flax seeds and whole grains.

Addition of antioxidants to food delay the formation of toxic oxidation products, maintain nutritional quality, and extend the shelf-life of products, [5]. Polyphenols are natural antioxidants and the possibility of their use as an antioxidant in food and as a dietary supplement is increasingly being studied, [6-8].

Rosmarinic acid (Fig. 1) is a phenolic compound whose antioxidant activity has been widely investigated and well documented including in vivo studies, some of which regard its efficacy in reducing diabetes, [9]. Although it is named after rosemary from where it was first isolated, one of the important sources of rosmarinic acid is lemon balm (*Melissa officinalis*), [10].

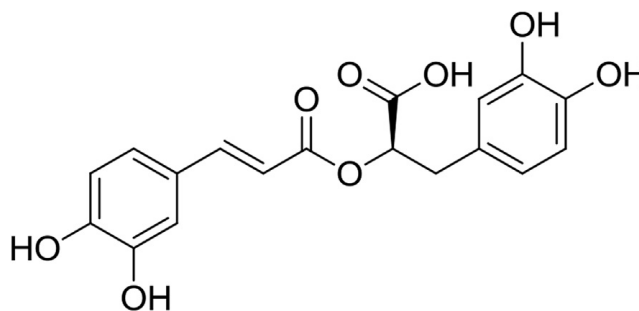

Fig. 1. Rosmarinic acid.

Lemon balm is a perennial herb from the mint family. The leaves, which have a mild lemon aroma, are used in traditional medicine. Lemon balm is used alone or as part of various multi-herb combination products. Lemon balm is used for anxiety, stress, insomnia, indigestion, dementia, and many other conditions. In foods and beverages, the extract and oil of lemon balm are used for flavoring.

The aim of this work was the application of NDESs to the green extraction of polyphenolic compounds of lemon balm. Extraction abilities of five NDESs were tested in comparison with conventional extraction with water. NDESs are highly viscous, which could obstruct mass transfer and lower the extraction yield, but their viscosities can be reduced significantly by simply adding an appropriate amount of water, [11]. Regarding this effect of water addition to the selected NDESs was also investigated.

MATERIAL AND METHODS

Materials

Dried lemon balm (*Melissa officinalis*) were purchased from Institute of Medicinal Plants Research "Dr Josif Pancic" (Belgrade, Serbia).

Lactic acid and malic acid were produced by Acros Organics (New Jersey, USA), choline chloride by Merck (Darmstadt, Germany), citric acid, glucose and sucrose by Fisher Scientific (Loughborough, UK) and betaine by Sigma-Aldrich Chemie (Steinheim, Germany). Formic acid (HCOOH) used for HPLC analysis was produced by Merck (Darmstadt, Germany) and methanol (MeOH) by J.T. Baker (Deventer, Netherlands).

Preparation of NDESs

Vacuum evaporating method, [12] was used for preparing natural deep eutectic solvents (NDESs) in certain molar ratios as listed in Table 1.

Briefly: components were dissolved in water and evaporated at 60°C with a rotatory evaporator (Heidolph Hei-VAP Value, Schwabach, Germany). The liquid obtained was put in a desiccator with silica gel till they reached a constant weight.

Table 1. Compositions of prepared NDESs

NDES	Abbreviation	Molar ratio
Lactic acid: Glucose	LA-Glu	1: 1
Choline chloride: Malic acid	ChCl-MA	1.5: 1
Betaine: Citric acid	B-CA	1: 1
Choline chloride: Malic acid: L proline	ChCl-MA-LPro	1: 1: 1
Betaine: Sucrose	B-Suc	2:1

Extraction procedure

0.1 g of grinded plant material was placed in 10 mL glass with 1.5 ml of solvent, covered with aluminium foil and heated to a temperature of 40°C using orbital shaker Ika KS 4000 i control (IKA-Werke, Staufen, Germany) during 1 h at 150 rpm. Beside mentioned NDESs extraction was done with demineralized water (W).

The results showed that the B-Suc mixture was the most suitable for the extraction of rosmarinic acid, so the influence of the water addition to this mixture was also examined. The 50 % w/w water was added to the eutectic mixture B-Suc and this mixture (B-Suc-W) was used to extract lemon balm as it's described above.

After finishing the extraction processes samples were centrifuged in an Eppendorf Centrifuge 5430 R (Eppendorf AG, Hamburg, Germany) at 20 °C and 15,000 rpm for 15 minutes. After centrifugation, the supernatant was separated from the precipitate, filtered through a cellulose acetate syringe filter 0.2 µm (Agilent, Santa Clara, US) and used in the analyzes.

HPLC analysis

Quantitative analysis of samples was done by Dionex Ultimate 3000 Thermo Scientific (Waltham, USA) HPLC system and a reverse phase column (PerkinElmer C18, 150 mm × 4.6 mm, 5 µm). Mobile phase was composed of solvent (A) H₂O: HCOOH = 100:0.1 % and solvent (B) MeOH:HCOOH=100:0.1 %. It was conducted by gradient elution in a following way: 0-30 min 10 - 35 % B, then 30-30.1 min 35-100 % B, 30.1 - 35 min 100 % B, 35-35.1 min gradient from 100-10 % B and 35.1-45 min 10 % B. A flow rate of 1.0 ml/min was used and column was thermostated at 30 °C. Injection volumes of extract and standards (0.5 mM) were 15 and 5 µl, respectively. Detection of compounds was carried out by UV detector at 280 and 310 nm.

Determination of phenolic content

UV spectra of the extracts was obtained on Shimadzu UV-1800 (Kyoto, Japan). Two absorption peaks around 280 and 320 nm characteristic for chlorogenic acid were measured to estimate the total polyphenol content in the extracts.

RESULTS AND DISCUSSION

Concentrations of rosmarinic acid in extracts, obtained by HPLC analysis are shown on Fig. 2. It could be seen that concentration of rosmarinic acid as a main phenolic compound in the lemon balm is much higher in the water extract comparing to all extracts with NDESs. All used NDESs are very viscous and that viscosity of the solvents affected the mass transfer and extraction efficiency. Addition of water to the B-Suc mixture lowered viscosity and in the concentration of rosmarinic acid was the highest in this extract. Also, could be seen that yield of rosmarinic acid is gained with eutectic mixtures containing betaine.

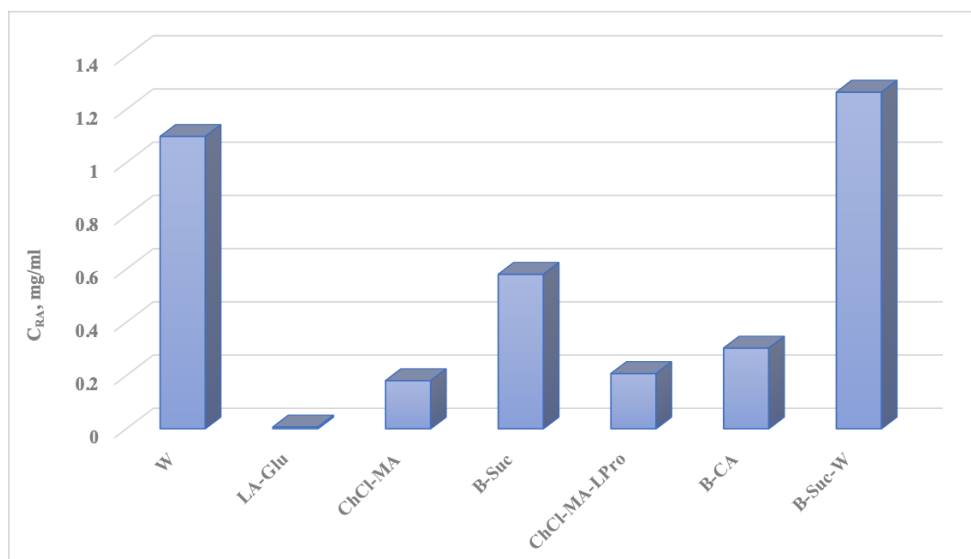

Fig. 2. Concentration of rosmarinic acid in extracts.

HPLC chromatograms of water extract and B-Suc extracts are shown on Fig.3. By comparing these chromatograms, it could be seen that a larger number of peaks is present in the extract obtained using the eutectic mixture. This means that eutectic mixtures extract more active components from the lemon balm than the conventional water extraction.

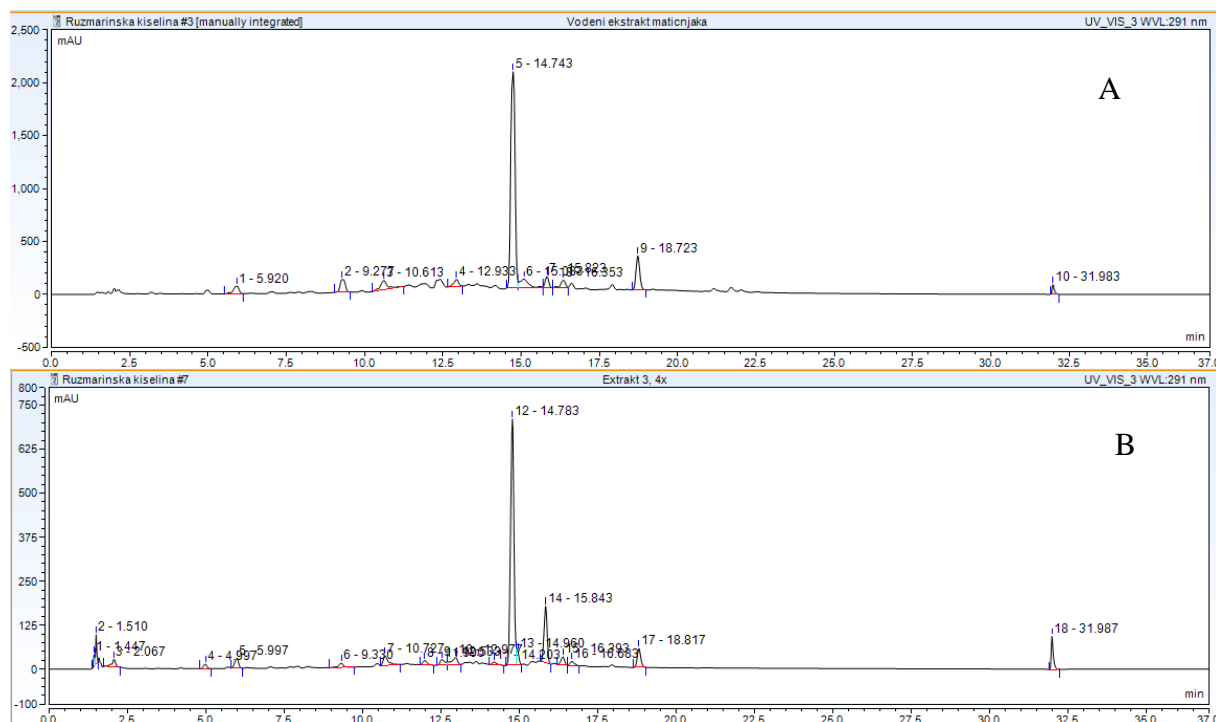

Fig. 3. Comparison of HPLC chromatograms of water extract (A) and betaine: sucrose extract (B)

Total phenolic content in extracts obtained by NDESs was estimated using UV spectra (Fig. 4). UV spectra of the extracts were very similar, showing the same pattern (two absorption peaks of high intensity around 280 and 320 nm) characteristic for chlorogenic acid (including rosmarinic acid), but also carnosic acid, one of the main constituents of *R. officinalis* phenolic fraction. UV spectral analysis indicates that the highest phenolic content was obtained using B-Suc, followed by B-CA, while three other NDES extracts contained similar amount of phenolic compounds as water extract.

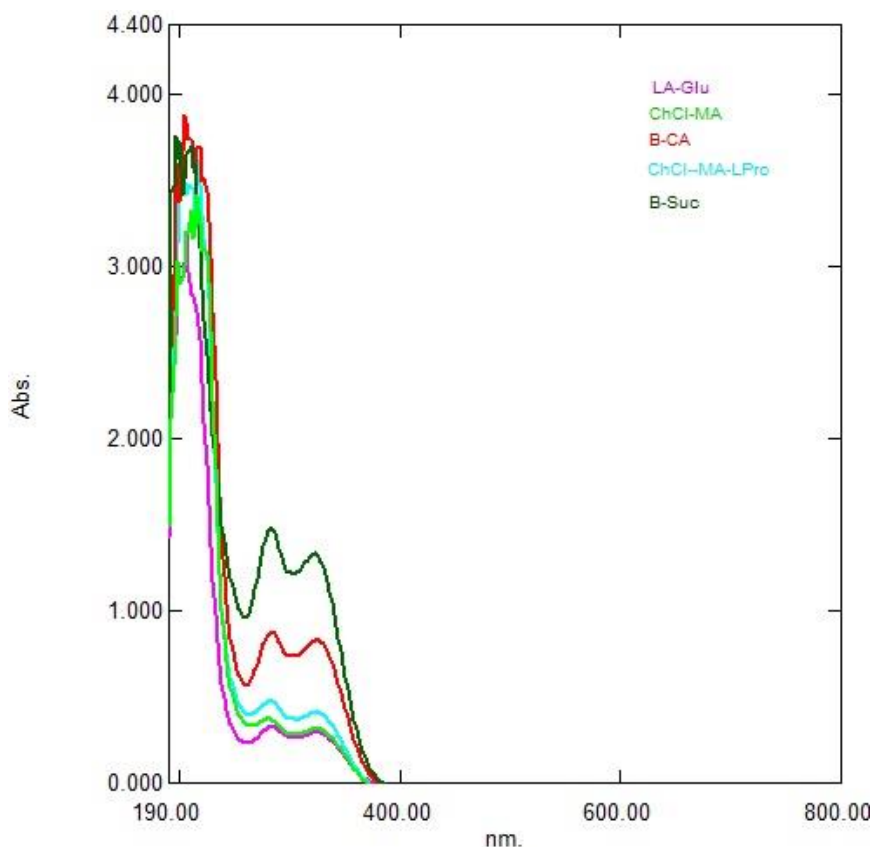

Fig. 4. UV spectra of NDESs extracts

CONCLUSION

The investigated NDESs (except LA-Glu) can be successfully used for the extraction of lemon balm (*Melissa officinalis*), but concentration of rosmarinic acid are lower than concentration in water extract.

Results shows that total phenolic content in extracts is higher when NDESs containing betaine were used for extraction than when water was used. Also, more different active compounds are present in the NDESs extracts.

Addition of water to eutectic mixtures affect solvent viscosity, intensify mass transfer and leads to higher yields of actives.

REFERENCES

- [1] Vilková, M., Płotka-Wasyłka, J., Andruch, V., The role of water in deep eutectic solvent-base extraction, *Journal of Molecular Liquids*, Vol.304, 112747, 2020.
- [2] Miličević, N., Panić, M., Valingera, D., Cvjetko Bubalo, M., Benković, M., Jurina, T., Gajdoš Kljusurića, J., Radojčić Redovniković, I., Jurinjak Tušek, A., Development of continuously operated aqueous two-phase microextraction process using natural deep eutectic solvents, *Separation and Purification Technology*, Vol.244, 116746, 2020.
- [3] Zainal-Abidin, M.H., Hayyan, M., Hayyan, A., Jayakumar. N.S., New horizons in the extraction of bioactive compounds using deep eutectic solvents: A review, *Analytica Chimica Acta*, Vol.979., pp.1-23, 2017.
- [4] Choi, Y.H., Verpoorte R., Green solvents for the extraction of bioactive compounds from natural products using ionic liquids and deep eutectic solvents, *Current Opinion in Food Science*, Vol. 26, pp.87–93, 2019.
- [5] Shahidi, F., Ambigaipalan, P., Phenolics and polyphenolics in foods, beverages and spices: Antioxidant activity and health effects – A review, *Journal of Functional Foods*, Vol. 18, Part B, pp. 820-897, 2015.

- [6] Alañón, M. E., Ivanović, M., Pimentel-Mora, S., Borrás-Linares, I., Arráez-Román, D., Segura-Carretero, A., A novel sustainable approach for the extraction of value-added compounds from *Hibiscus sabdariffa* L. calyces by natural deep eutectic solvents., *Food Research International* Vol.137, 109646, 2020.
- [7] Radošević, K., Curko, N., Gaurina Srček, V., Cvjetko Bubalo, M., Tomasević, M., Kovacević Ganić, Radojčić Redovniković, I., Natural deep eutectic solvents as beneficial extractants for enhancement of plant extracts bioactivity, *LWT - Food Science and Technology* Vol. 73, pp.45-51, 2016.
- [8] Bakirtzi, C., Triantafyllidou, K., Makris, D.P., Novel lactic acid-based natural deep eutectic solvents: Efficiency in the ultrasound-assisted extraction of antioxidant polyphenols from common native Greek medicinal plants, *Journal of Applied Research on Medicinal and Aromatic Plants*, 2016.
- [9] Binello, A., Cravotto, G., Boffa, L., Stevanato, L., Bellumori, M., Innocenti, M., Mulinacci, N., Efficient and selective green extraction of polyphenols from lemon balm, *Comptes Rendus Chimie*, Vol. 20, pp. 921-926, 2017.
- [10] Caleja, C., Barros, L., Barreira, J.C.M., Ciric, A., Sokovic, M., Calhelha, R.C., Beatriz, M., Oliveira, P.P., Ferreira, I.C.F.R., Suitability of lemon balm (*Melissa officinalis* L.) extract rich in rosmarinic acid as a potential enhancer of functional properties in cupcakes, *Food Chemistry*, Vol. 250, pp. 67-74, 2018.
- [11] El Achkar, T., Fourmentin, S., Greige-Gerges, H., Deep eutectic solvents: An overview on their interactions with water and biochemical compounds, Vol. 288, 111028, 2019.
- [12] Dai, Y., van Spronsen, J., Witkamp, G.J., Verpoorte, R., Choia, Y.H., Natural deep eutectic solvents as new potential media for green technology, *Analytica Chimica Acta*, Vol. 766, pp. 61– 68, 2013.

INTERACTIONS OF CLIMATE CHANGE WITH FOOD SECURITY AND GOALS OF SUSTAINABLE DEVELOPMENT IN AGROECOSYSTEM

Hosam Bayoumi Hamuda¹

¹Óbuda University, Rejtő Sándor Faculty of Light Industry & Environmental Engineering
Institute of Environmental Engineering & Natural Sciences, Budapest-Hungary

e-mail: bayoumi.hosam@rkk.uni-obuda.hu

Abstract: Climate change can either positively or negatively affects the activities of agroecosystem. The two-way relationship between agroecosystem and climate change has important economic and developmental implications for numerous regions worldwide. The link between climate change and the agroecosystem implies complex interactions and can be described as a two-way relationship. Climate change is not only increasing ambient temperature but also accelerating the frequency, duration and intensity of extreme weather and climate events, such as heavy precipitation and droughts, and causing sea level rise, which can lead to population displacement. Climate change-related reductions in land productivity and habitability and in food and water security can also interact with demographic, economic and social factors to increase migration. In addition to migration, climate change has also implications for travel and the risk of disease. Most of the early approaches to assessing the impact of climate change on agroecosystem focused on a single variable which is temperature. However, this variable would drop to 63% if temperatures were to rise by 2°C and therefore have implications for an agroecosystem balanced the economic growth of its productivity. The purpose of this paper is to present an overview of the existing literature on the relationship between agroecosystem and climate change in order to establish the current state of sustainable development.

Key words: Agroecosystem, Climate Change, Food Security, Interaction, Sustainable Development

INTRODUCTION

Global environmental change is a clear phenomenon in a variety of ways that are evident to any ecologist [1]. Perhaps the most obvious of these changes to many ecologists is the loss of old and acquisition of new species in the ecosystems studied. Over the time, it was observed that rare species disappear from landscapes, and new species arrive through a still-accelerating pace of biological invasions. As a form of global environmental change, biotic homogenization has far reaching consequences for both ecology and evolution that have yet to fully comprehend. Land use changes, habitat degradation and introduction of invasive species to ecosystems are among the main causes of biodiversity loss [2]. The ongoing biodiversity loss due to human actions is an undeniable crisis [2]; [3]. These changes in the global ecosystem are due to the climatic changes. Climate change reveals an unprecedented level of human intervention in ecological systems and processes. One factor that can potentially impact on perceived satisfaction is climate. Most of the early approaches to assessing the impact of climate change on agroecosystem focused on a single variable which is temperature. This literature suggests that climate change impact the natural environment of an agroecosystem. One potential threat to the future viability of the productivity of an agroecosystem identified in recent years is climate change. Climate change has the potential to impact on both the supply- and demand-sides of the product from economical point of view. There are multiple interactions between agroecosystem and the climate. Climate change threatens all life on the planet, as well as the very destinations that agroecosystem relies on. An agroecosystem depends on natural resources, such as water, landscapes, soil type, biodiversity, etc. These influence the potential attraction of the sustainable development of the system. However, climate change threatens the loss of some of these relevant natural resources.

As the planet warms, rising sea levels, extreme weather, and increasing temperatures are impacting ecosystems and communities around the World. Traditional and indigenous knowledge is the indispensable information base for many societies seeking to live in harmony with nature and adapt to disruptive weather events, a warming globe and rising seas.

Climate is a resource for agroecosystem and it is an essential ingredient in the agroecosystem product and experience. At the same time, climate poses a risk to agroecosystem. Risk is potential loss and opportunity is possible gain. Over the last few years there has been increasing recognition of the risks

and opportunities that climate change brings to the agroecosystem. In fact, climate-change research on urban scales has become recently an important and urgent topic [4].

AGROECOSYSTEM

The conversion of natural ecosystems into agricultural systems mediated by human activities (i.e., agroecosystems [5] is a main driver of changes in species composition. Assemblages in agroecosystems are often remarkably different from those in native environments [6].

Agro-ecology is a science that is based both on traditional knowledge and on advances being made by modern agricultural science (excepting, of course, transgenic biotechnology and pesticides), and utilizing elements of contemporary ecology, soil biology, biological control of pests, etc. A United Nations 2011 press release on its report "Agro-ecology and the right to food" states that: "Small-scale farmers can double food production within 10 years in critical regions by using ecological methods." Such agro-ecological methods are also safer from an environmental and health perspective. Ecosystem services are defined as the benefits that humans obtain from ecosystems. In recent years, this concept has become the paradigm of ecosystem management. Agro-ecology is most feasible for small and middle-size family units, and could actually play an important role in reversing the exodus to cities. The United Nations recently declared 2014 as the International Year of Family Farming, celebrating the global community of family farmers, to highlight the importance of family and smallholder farmers.

The International Assessment of Agriculture Knowledge, Science and Technology for Development report, the world's largest study on agriculture commissioned by the World Bank, Food & Agriculture Organization, World Health Organization, and other international organizations found that agro-ecological approaches, and not GM, provide a sustainable answer to the world's food crisis. This has recently been further substantiated by the UN Rapporteur on Food who states "To date, agro-ecological projects have shown an average crop yield increase more than 80% in 60 developing countries demonstrated a doubling of crop yields over a period of 3-10 years. Countries with an average increase of 116% for all African projects. Recent projects conducted in 20 African countries demonstrated a doubling of crop yields over a period of 3-10 years.

THE CLIMATE SYSTEM

To understand the climate of the Earth, including its variations and changes over time and its interactions with agroecosystem, The system consists of the atmosphere, ice and snow masses, land surfaces, rivers, lakes and the biosphere (including humans), as well as the mutual interactions and hence changes that are a consequence of the large variety of physical, chemical and biological processes taking place in and between these components (Fig.1.).

Another key feature of the system is the existence of various external forcing mechanisms, the most important being the Sun. Agroecosystem is one of many contributors to changes in the climate system. As with other human activities, there are many ways and spatial scales at which agroecosystem contributes to climate change (Fig.1.).

The atmosphere is the most rapidly changing part of the wider climate system, its composition having changed as the Earth has evolved. Despite their concentrations relative to gases such as nitrogen (N₂) and oxygen (O₂), a collection of atmospheric gases, notably CO₂, methane (CH₄), nitrous oxide (N₂O), ozone (O₃) and water vapour (H₂O), play a critical role in determining the temperature of the Earth. These so-called greenhouse gases absorb little or none of the short-wavelength radiant heat energy reaching the Earth from the Sun, but are highly effective absorbers of the longer-wavelength radiant heat energy emitted by the Earth. These gases, in turn, emit longer-wavelength radiant heat energy both upward and downward (Fig.2.). The resulting energy-'trapping' process raises the temperature of the Earth's surface to an average of 14°C, some 33°C above what it would be if the Earth's atmosphere contained no GHGs. This raised temperature is termed the natural greenhouse effect.

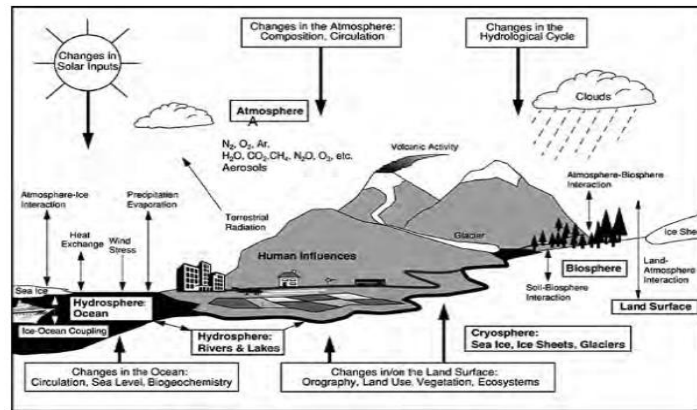

Fig. 1. Contributions of agroecosystem and other human activities to global climate change

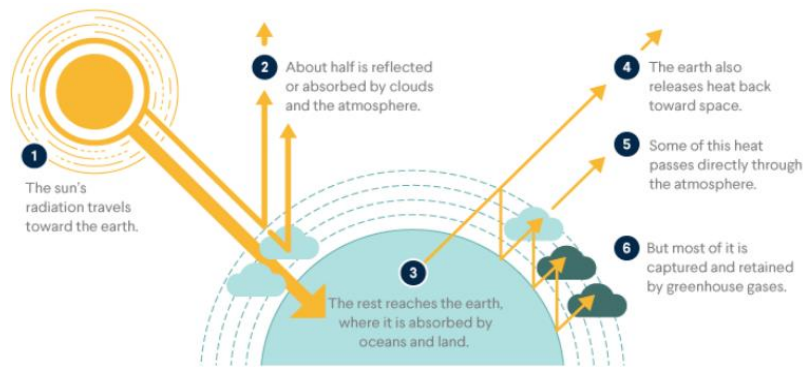

Fig. 2. Greenhouse effect

For centuries prior to the Industrial Revolution the concentrations of GHGs in the atmosphere remained relatively constant. But since then the concentrations have increased, largely as a result of the combustion of fossil fuels for industrial and domestic purposes, and due to biomass burning and deforestation. For example, the CO_2 concentration has increased by more than 30%, and is still increasing at the unprecedented annual average rate of 0.4%. The concentrations of other GHGs, such as CH_4 and N_2O , are also increasing, due to agricultural and industrial activities. The concentrations of the nitrogen oxides (NO and NO_2) and of carbon monoxide (CO) are also increasing. While these are not GHGs, they are involved in chemical reactions that result in higher ozone concentrations in the lower atmosphere. Ozone is a GHG, and its concentration has increased by 40% since pre-industrial times. This increasing concentration of GHGs is exacerbated by chlorofluorocarbons (CFCs) and other chlorine and bromine compounds. These do not occur naturally, but are manufactured for industrial and domestic use. In addition to being strong GHGs, they destroy stratospheric ozone. The increased concentration of GHGs in the atmosphere enhances the absorption and emission of long-wavelength radiant heat energy. The overall effect is a reduction in the long-wavelength radiant heat energy lost to space. This must in turn be compensated for by an increase in the temperature of the Earth's surface and lower atmosphere.

Abrupt climate changes of up to 10°C in a decade have been identified in some regions. Although abrupt climate change can occur for many reasons, it is conceivable that human forcing of climate change is increasing the probability of such large and abrupt events. Available evidence suggests that abrupt climate changes are not only possible but likely in the future, potentially with large impacts on ecosystems and societies. Figure 3 illustrates how CO_2 is absorbed by trees and soils and thereby taken out of the atmosphere. A potential co-benefit of this form of carbon sequestration is a gain in biodiversity.

Climate change is expected to increase the risk of illness in several parts of the World and consequently discourage the protectively of the agroecosystem. At the same time agroecosystem is a very energy-intensive activity that contributes to greenhouse gas emissions and the build-up of these gases in the atmosphere [7].

By resolution 64/200 of 21 [8] the General Assembly decided to designate 13 October as the date to commemorate the Day and to change the Day's name to International Day for Disaster Reduction. The objective of the observance is to raise awareness of how people are taking action to reduce their risk to disasters. The focus of this year's International Day for Disaster Reduction is on the traditional, indigenous and local knowledge which complement modern science and add to an individual's and societies' resilience. For example, knowledge of early warning signals in nature can be vital to ensuring early action is taken to mitigate the impact of both slow and fast onset disasters such as droughts, heat-waves, storms and floods. Combined with scientific knowledge such as reports generated by meteorologists, local knowledge is vital for preparedness and can be passed on from generation to generation.

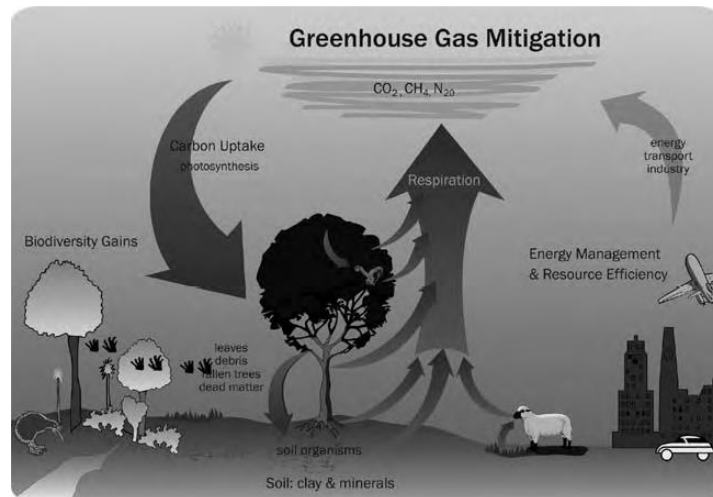

Fig. 3. Carbon cycle and sequestration of CO₂ through forest sinks

Climate change impacts will affect social and ecological systems in complex and broad-ranging ways as technological, economic, social and ecological changes take place across regions, groups and sectors. Many of these impacts, such as impacts on ecological systems, have cascading effects on social, economic and health outcomes. In order to respond to climate change, more vigorous actions are required to mitigate emissions of greenhouse gases (GHGs) and to adapt to unavoidable consequences that are increasing vulnerability around the world. This training places local sustainability, its development challenges and local vulnerabilities in the context of climate changes at regional and global levels in order to understand their linkages. It is well recognized that a response strategy to climate change is an additional and new area of sustainable community development, that in addition to many other local priorities like reducing poverty, improving sanitation and safe access to fresh water, health issues and diminishing ecological resiliency.

THE RELATIONSHIP BETWEEN AGROECOSYSTEM AND CLIMATE CHANGE

Interventions or responses designed to reduce climate-related risks fall into two categories: mitigation and adaptation. Mitigation includes initiatives for reducing GHG emissions, whereas adaptation refers to interventions that reduce the vulnerability to climate change impacts. With the increasing recognition of climate change as a major environmental issue that must be addressed in a concerted manner, there is a developing consensus on policies such as taxing services for their emissions of GHGs[9], [10 g. These diverse relationships between agroecosystem and climate are visualised in a simplified manner in Fig.4. The consequences of climate change for agroecosystem manifest as risks. The decision maker and planner will find it useful to differentiate between acceptable and unacceptable risks.

Interventions or responses designed to reduce climate-related risks fall into two categories (Fig. 4). First, mitigation initiatives reduce GHG emissions. Emissions reductions of at least 60% are required to stop further increases in the greenhouse effect. In comparison, the Kyoto Protocol will achieve

emission reductions of only 5.5% reduction in emissions, and only if there is full compliance! Thus further climate change is inevitable.

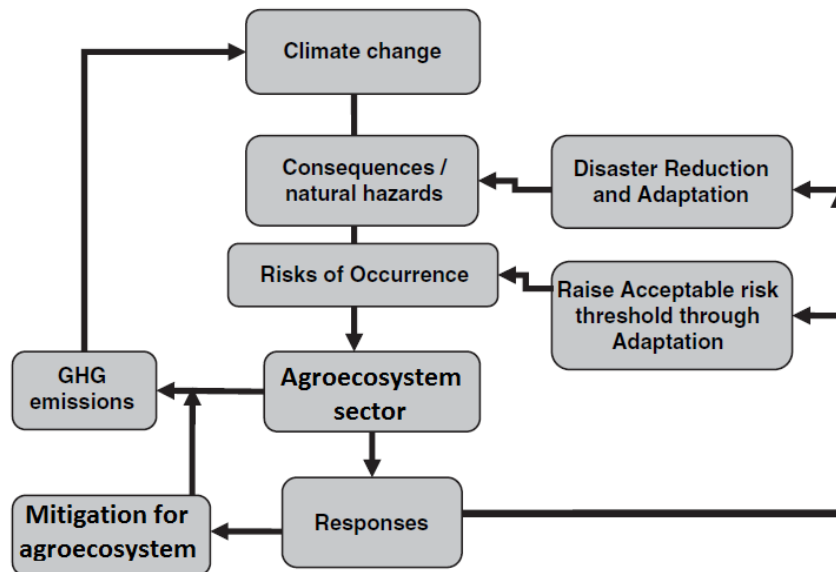

Fig. 4. Framework for assessing the relationship between agroecosystem and climate change, including possible responses by agroecosystem to mitigate impacts or adapt to changes in the climate

Moreover, even if the necessary reductions in emissions were to be achieved tomorrow, changes in the climate will still occur. This is due to inertia in the climate system. Thus mitigation brings climate benefits only in the longer term. However, mitigation of GHG emissions does generate short-term opportunities and benefits for agroecosystem, for example through energy conservation and increased use of renewable energy. Unlike mitigation, these interventions deal with the consequence component of risk. These interventions reduce risk through disaster reduction and wider adaptation initiatives.

For example: Figure 4 assumes that the relationships are linear and that the interactions between agroecosystem and climate are deterministic. In this logic it is possible to control the effects, i.e. reduce the risks and maximise the opportunities. In fact, both agroecosystem and climate operate individually and jointly as open systems that are also non-linear, non-probabilistic and non-deterministic as a result of the complex, dynamic relations between and among them and their constituent elements. Thus it is inappropriate to pursue a reductionist approach to understanding the interactions between the agroecosystem and climate systems, as would be the case if each component and linkage shown in Fig.4 was to be analysed individually. Importantly, characterising and combining the individual interactions will in itself not provide a fully integrated understanding of the relationships between agroecosystem and climate. The main elements of a agroecosystem are environment: human, sociocultural, economical, technological, physical, political, legal, etc. that are involved directly or indirectly in agroecosystem activities.

ADAPTATION RISK

One consequence of the open nature of the agroecosystem is a need for sectors cooperation when addressing the consequences of climate change. As risk assessment and management procedures have already been embraced by many sectors e.g., health, financial, transport, agriculture, energy and water resources. A risk-based approach (Fig.5) provides a common framework that facilitates coordination and cooperation amongst the various players, including the sharing of information that might otherwise be retained by information ‘gate keepers’.

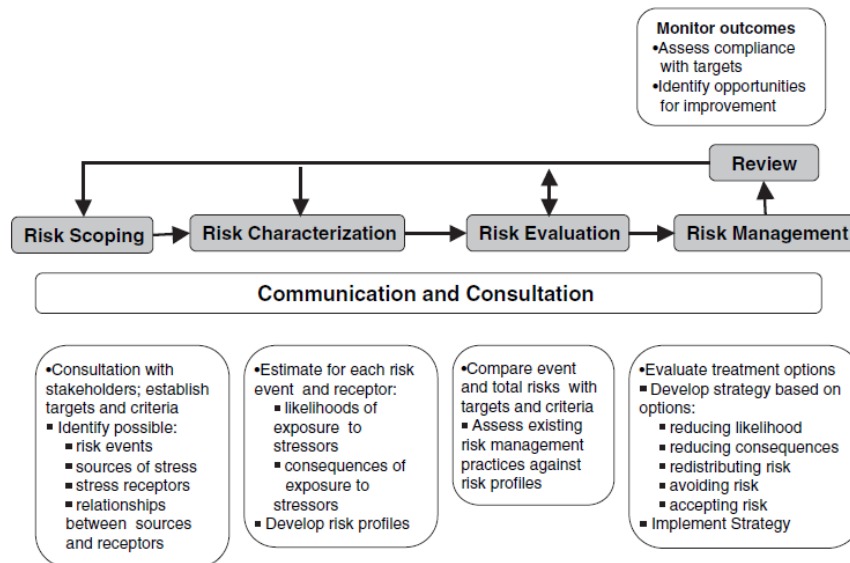

Fig. 5. Risk-based approaches to identifying and assessing options for managing the adverse consequences of climate change

Importantly, the existing familiarity of many planners and decision makers with risk management helps facilitate the mainstreaming of risk-based adaptation. Risk-based methods also facilitate an objective and more quantitative approach, including cost benefit analyses that not only assist in evaluating the incremental costs and benefits of adaptation and but also help in prioritising adaptation options. The approach also links to sustainable development by identifying those risks to future generations that present generations would find unacceptable.

The risk scoping and characterisation steps (Fig.5) facilitate identification of both the direct and indirect consequences of climate change. Overall, the risk-based approach ensures there is a strong functional link between the assessments of the risk and the identification, prioritisation and eventual selection of the adaptation initiatives required reducing the risks to acceptable levels.

Figure 6 illustrates the many dimensions to such a policy framework and process. Firstly, the framework acknowledges the iterative nature of the policy development process. The first iteration of the cycle will normally start with activities designed to support informed decision making related to the mitigation and adaptation initiatives to be undertaken. A strong enabling environment is critical to the successful implementation of those initiatives; while continuous improvement is ensured by reviewing the effectiveness of the implemented measures. The information gained in the monitoring process will be used as input into the decision making in the next iteration.

Monitoring vegetation (including the crops production) change and their potential drivers are important to environmental management. Recently, climate variables and human activities are two main drivers that could deeply influence the agroecosystem on the Earth. The climate system has been modified by humans as a result of GHG emissions. These ‘trap’ solar energy and raise the temperature of the Earth’s surface. This raised temperature is termed the natural greenhouse effect. Climate projections are associated with considerable uncertainties. Climate variables such as precipitation, temperature, and sun radiation drive the plant physiological processes such as photosynthesis, respiration, and transpiration, while human activities, such as urbanization, deforestation, grazing prohibition policy, reclamation of land from lakes, market fluctuation etc., could directly or indirectly change the processes of dynamics of the agroecosystem by modifying ecosystem composition and distribution.

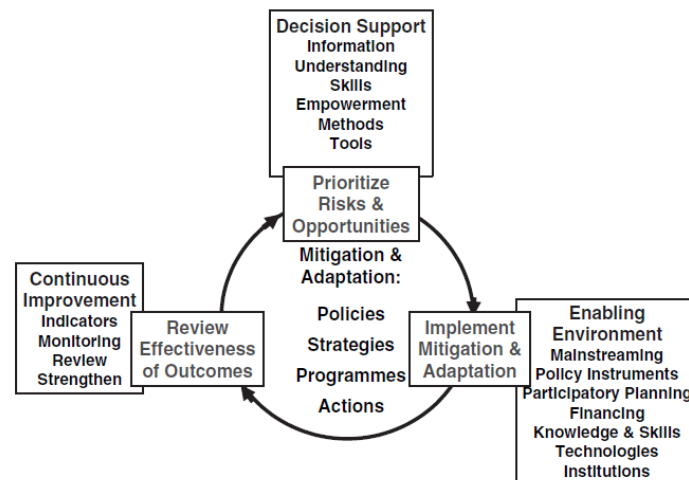

Fig. 6. Framework for climate change mitigation and adaptation

As usual, the associated relation with human induced land cover transitions such as deforestation, urbanization, land reclamation, or extremely climate events such as flood and drought. While gradual changes usually happen gradually and continuously, which indicate gradual improvement or deterioration of plant coverage or species composition in an agroecosystem associated with global warming, soil erosion, fertilizing, irrigation, or nurturing. These kinds of behaviours could be related to climate gradual change or indirect human activities such as environmental management, policy alteration, or market fluctuation.

Studies on agroecosystem changes detection and causative agent discrimination should be treated as follow-up flow for there are inner causality mechanisms between them. Agroecosystem areas controlled by human activities may have more dramatic change rates comparing with the areas controlled by climate factors.

Climate and in particular temperature is an important factor in agroecosystem services. Special attention was focused on the challenges of adaptation to changing climates and environments in urban areas worldwide. It deliberately moves away from conventional boundaries of urban climate/environmental change research that continue to dichotomize the frames of reference of this world into rich versus poor or North versus South. The rationale is threefold:

- In an integrated yet differentiated global system, key contemporary fault lines and differences no longer follow those historical cleavages.
- Climate changes do not follow national or regional boundaries while globalised economic processes often link geographically remote urban, peri-urban and rural localities distally.
- Finally, strategies for mitigating and adapting to environmental change seem increasingly to resonate across distally connected towns and cities of diverse locations, histories and geopolitical orientations.

CLIMATE STUDY FOR BETTER AGRICULTURE

The agricultural crisis is going to be on the other by the ‘natural’ calamities: drought, floods, upheavals in climate, etc. Snowfall, rainfall in 24 hours on summer; -30°C on February and etc., Coming within such a short span, these deviations from what is seen as normal have caused alarm among agricultural scientists, who stress the need for continuous research on the impact of climate changes on the agriculture of a state whose produce feeds half the nations.

Requirements:

- Climate protection study for better agriculture
- Urge nations to cut down on pesticide use
- Perishable production
- Food Act to benefit to face the increases the global population
- Study links pesticides and Cancer

- Biotechnology Regulatory Authority in the world
- GMOs - Concerns & Impacts
- Towards reviving a biodiverse farming system for food sovereignty

Objectives:

- Reflections - Past, Present and Future
- Agrobiodiversity: Past and Present
- Agro-ecology: Towards a healthier tomorrow
- Protection of Plant Varieties
- Protection of agrobiodiversity, that consists of cultivated plants and domesticated animals
- Agrobiodiversity includes varietal diversity and the existence of a range of cropping strategies.
- Green Revolution
- Stop using GM seeds, chemical fertilizers and pesticides.

Principles and key concepts

- Introduction to climate change and climate change adaptation
- Strategy development and planning for Climate Change Adaptation
- Legal frame work for Climate Change Adaptation
- Monitoring Vulnerability

Introduction to GIS for Climate change

- Introduction to GIS software
- Planning for a GIS system installation
- Working with a GIS software, data collection

Impacts of Climate Change and their Assessment

- Economic sector
- Social structure
- Agriculture
- Natural resources
- Migration and disasters

Climate Change Response

- Creating Responses: Determining the adaptation options
- Mainstreaming climate change into development decisions
- Developing adaptation responses
- Contingency Planning

AIMS OFFOOD SECURITY IN RELATION WITH CLIMATIC CHANGES

Climate change is a threat multiplier for hungry and undernourished people. Combined with conflict, it destroys livelihoods, drives displacement, widens inequalities, and undermines sustainable development including our goal of zero hunger by 2030. It is found that of the four main elements of food security, i.e., availability, stability, utilization, and access, only the first is routinely addressed in simulation studies. To this end, published results indicate that the impacts of climate change are significant, however, with a wide projected range (between 5 million and 170 million additional people at risk of hunger by 2080) strongly depending on assumed socio-economic development. The likely impacts of climate change on the other important dimensions of food security are discussed qualitatively, indicating the potential for further negative impacts beyond those currently assessed with models [11]. Thus, fundamental changes in agricultural systems are needed because climate change poses new and serious challenges for farmers hence food insecurity. Most important, agricultural adaptation and mitigation pathways need to be developed so as to avoid further threat on food security [12, 13].

These disasters have also disproportionately harmed low-income people and their access to food, which is why we have chosen to focus on the connection between climate change and food security in the 2019 Global Hunger Index (GHI), prepared by Concern Worldwide and Welthungerhilfe. Sadly, this is not a trend that appears to be going away any time soon. Looking ahead, climate models predict higher average temperatures in most land and ocean regions, hotter extremes in many inhabited regions, and both heavy precipitation and an increasing probability of drought in some areas. These are all additional challenges for reducing hunger.

Climate change and food security: Fast facts:

- Climate change is a threat multiplier for hungry and undernourished people.
- Countries with high levels of hunger are often also highly vulnerable to climate change, and have a low capacity to adapt.
- Climate change affects food production and availability, access, quality, utilization, and stability of food systems. In short, it impacts all aspects of the food system.
- Extreme weather-related disasters are increasing and reduce the yields of major crops.
- Higher levels of CO₂ reduce the nutritional value of crops.
- The global food system contributes about one-third of greenhouse gas emissions. About ⅓ of food are lost and wasted from farm to table. These losses therefore exacerbate climate change without improving food security or nutrition.
- Climate change and conflict combined destroy livelihoods, drive displacement, widen inequalities, and undermine sustainable development.
- Ending hunger and under nutrition in a changing climate demands large-scale action.

Climate change threatens agriculture and food production:

- Higher temperatures, water scarcity, extreme events like droughts and floods, and greater CO₂ concentrations in the atmosphere have already begun to impact staple crops around the world. Maize and wheat production has declined in recent years due to extreme weather events, plant diseases, and an overall increase in water scarcity.
- According to the Food and Agriculture Organization of the United Nations, the unpredictable yield for cereal crops in semi-arid regions of the world (like the Sahel region of Africa) is at least 80% the result of climate variability.

Alternatively, climate change can adversely affect the nutritional value of food that is grown. Studies show that higher carbon dioxide concentrations reduce the protein, zinc, and iron content of crops. By 2050, an estimated additional 175 million people could have zinc deficiencies and an additional 122 million people could be protein deficient. Communities relying largely on plant harvests for their nutrition will, again, feel this most acutely.

Beyond plant-based nutrition, this also has a ripple effect on livestock, who rely on the same resources as humans to eat, grow, and produce meat and/or milk. Livestock are also severely threatened by drought, accounting for 36% of drought-related losses (crops account for 49%). Climate extremes also threaten fish populations, especially in areas like Southeast Asia. Rain doesn't guarantee healthy crops, either. Higher rainfalls or flooding can produce toxic mold on crops. Crops grown in high-drought areas that are then moved into humid storage facilities are vulnerable to fungal infections or pests. The more climate changes and the more that extreme climate events become commonplace, the more food we lose on an annual basis. Figure 7 shows how these tools can be used to inform multi-stakeholder coordination processes that seek to mainstream climate change adaptation into sustainable development approaches.

Climate change does not yet feature prominently within the environmental or economic policy agendas of developing countries. Climate change results from activities all over the globe, it may lead to very different impacts in different countries, depending on local/regional environmental conditions and on differences in vulnerability to climate change—independent of the contributions to climate change of these countries.

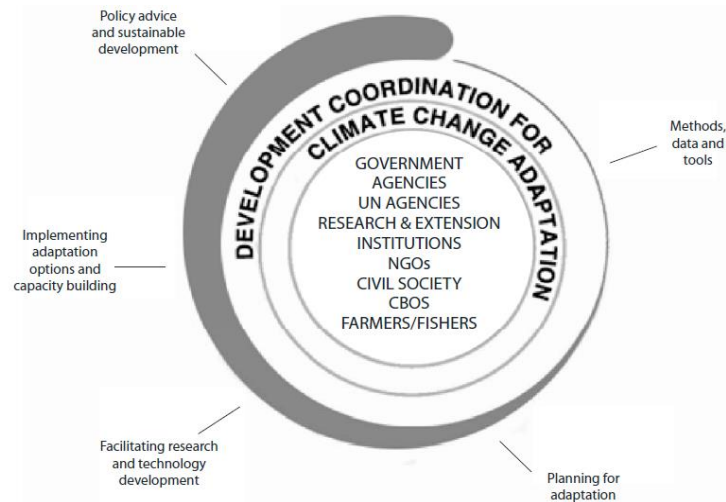

Fig. 7. Multi-stakeholder processes for mainstreaming climate change adaptation into sustainable development approaches [14]

LINKAGES BETWEEN CLIMATE CHANGE AND SUSTAINABLE DEVELOPMENT

The purpose of this part is to raise critical issues on the relationship between climate policy and sustainable development. It criticizes current policy approaches, including that reflected in the Kyoto Protocol, on the grounds that they have inadvertently resulted in the placing of climate policy and development into separate boxes. Policy experience on climate stabilization has developed largely within the institutional, economic, and political context of industrialized countries, but policy analysis now needs to turn single-mindedly to the situation of developing countries.

Yet evidence shows that some of the most adverse effects of climate change will be in developing countries, where populations are most vulnerable and least likely to easily adapt to climate change, and that climate change will affect the potential for development in these countries. Some synergies already exist between climate change policies and the sustainable development agenda in developing countries, such as energy efficiency, renewable energy, transport and sustainable land-use policies. Despite limited attention from policy-makers to date, climate change policies could have significant ancillary benefits for the local environment. The reverse is also true as local and national policies to address congestion, air quality, access to energy services and energy diversity may also limit GHG emissions. Nevertheless, there could be significant trade-offs associated with deeper levels of mitigation in some countries, for example where developing countries are dependent on indigenous coal and may be required to switch to cleaner yet more expensive fuels to limit emissions. The distributional impacts of such policies are an important determinant of their feasibility and need to be considered up-front. It follows that future agreements on mitigation and adaptation under the convention will need to recognise the diverse situations of developing countries with respect to their level of economic development, their vulnerability to climate change and their ability to adapt or mitigate. Recognition of how climate change is likely to influence other development priorities may be a first step toward building cost-effective strategies and integrated, institutional capacity in developing countries to respond to climate change. Opportunities may also exist in developing countries to use regional economic organisations to assist in the design of integrated responses and to exploit synergies between climate change and other policies such as those designed to combat desertification and preserve biodiversity.

The worst impacts will fall on developing countries, in part because of their geographical location, in part because of weak coping capacities, and in part because of more vulnerable social, institutional, and physical infrastructures. In the future, it would be necessary not only to induce adjustment in industrialized countries, but also to reorient the growth process in the developing world towards decarbonization. It is likely to undermine the sustainability of livelihoods as well as development.

Session 1.

Mechanical Engineering

DEVELOPMENT OF INNOVATIVE AND ENTREPRENEURIAL COMPETENCIES OF FUTURE ENGINEERS THROUGH THE ITlab PROJECT AT THE TECHNICAL FACULTY “MIHAJLO PUPIN” ZRENJANIN

**Dragica Radosav¹, Eleonora Desnica¹, Slavica Prvulović¹, Ljiljana Radovanović¹,
Jasmina Pekez¹, Vladimir Šinik¹, Ivan Palinkaš¹**

¹University of Novi Sad, Technical Faculty “Mihajlo Pupin”, Zrenjanin, Serbia

e-mail: desnica@tfzr.uns.ac.rs

Abstract: This project analyzes the role of new knowledge and the inevitable trend of the future, computer, and other communication, in the work of future engineers, as well as the importance of developing their entrepreneurial competencies, through the project "IT lab - laboratory for engineering analysis, modeling and simulation" at the Technical Faculty "Mihajlo Pupin," Zrenjanin. The project emphasizes the importance of dual and lifelong education as one of the elements that support the need for the introduction of some of the modern forms of learning. The project results can serve as proof of the justification of promoting entrepreneurship among students of technical and engineering educational profiles that will teach creative and innovative students how to start their business venture based on their engineering ideas.

Key words: entrepreneurial competencies, dual education, teaching improvement, IT lab

INTRODUCTION

Providing a skilled workforce for the economy is one of Serbia's key challenges (and other countries as well). The term "dual system" can, for example, refer to places of learning, but also intertwined pedagogical processes. In the first case, "duality" refers to alternately learning in the company and at school. In the second case, the "dual principle" refers to a combination of theory and practice [1].

For dual education, we often think that there is place only in high schools. Not only secondary vocational education is a functional measure for promoting economic goals, but faculties also apply it: Faculty of Organizational Sciences, Belgrade has more than 700 contracts with companies and student internships for ten years; The University of Novi Sad has made over 100 so-called spins of companies founded by professors and students, some of whom have 800 employees; Student projects at the Faculty of Electrical Engineering in Belgrade are also an essential type of dual education, students with companies implement innovative projects, concepts, innovation development so that their students are ready to enter the labor market and establish their own companies. Technical faculties are becoming an example for others [2].

THE IMPORTANCE OF PRACTICAL TRAINING AND DUAL EDUCATION IN THE PROFESSIONAL PREPARATION OF FUTURE ENGINEERS

Companies want staff that can be immediately involved in work processes, without an extended internship, and a safe way to provide staff, ready to get involved in the work, are practical training (professional internships) for students. Practical training, well designed, organizing professional visits of students to production companies and laboratories, introducing students to technological processes, machines and measuring equipment, reviewing technical documentation and insight into the situation in the factory, will contribute to better employment opportunities for graduate engineers in the economy. By adapting to the market, students are provided with practical knowledge, which can be applied immediately [2].

Dual education combines formal, university education, and informal acquisition of relevant professional knowledge and skills through student work on practical problems in companies. With this combination, students who want it get theoretical and required practical knowledge and skills. In this way, students are trained to acquire the competencies needed by employers, and students who are educated in this way find it easier to get better jobs.

At the Technical Faculty "Mihajlo Pupin," dual education is realized through two strategic directions. One is based on laboratory accreditation so that students can do not only regular classes but also applicable projects. The second strategy refers to students' professional practice after the third and fourth years of study, which has been realized for many years.

PROJECT IT LAB - LABORATORY FOR ENGINEERING ANALYSIS, MODELING AND SIMULATION

At the Technical Faculty "Mihajlo Pupin" in Zrenjanin, in the school year 2018/2019, the project "IT lab - laboratory for engineering analysis, modeling and simulation" was implemented, funded by the Ministry of Education, Science and Technological Development within the program activity "Development of high education." The objectives of this project were to contribute to the development of the educational process to improve the cooperation of higher education institutions with the economy and other stakeholders in the local community, and through the development of entrepreneurial competencies; innovating existing courses by increasing the use of information technology in teaching and developing digital competencies for work and future development. The project IT lab - laboratory for engineering analysis is designed to significantly contribute to the development of digital competencies of students and create a good foundation and critical competencies for lifelong learning. The project included three accredited study programs at the faculty - Mechanical Engineering (undergraduate studies), Information Technologies in e-Government (master studies) and Industrial Engineering in Oil and Gas Exploitation (undergraduate studies).

Realized project activities [3]

Promotion of the beginning of work on the project - was realized on November 20, 2018. in the small amphitheater of the Technical Faculty "Mihajlo Pupin" in Zrenjanin (Fig. 1).



Fig. 1. Promotion of the beginning of work on the project

Founding of IT lab - laboratory for engineering analysis, modeling, and simulation - which serves to improve the knowledge and skills of students in the field of mechanical engineering and information technology following the current market demand.

Procurement of software - the software's that are procured: Matlab (Mathworks - Software license Matlab Individual, Academic Perpetual; Mathworks - Software license Simulink Individual, Academic Perpetual); 3DExperience Catia; ArcGIS (Esri ArcGIS Academic Department License Medium)

Software installation and training for work - was performed on computers in the IT lab - laboratory for engineering analysis, modeling and simulation by the obtained licenses. Teachers, associates, and students are trained to work on Matlab, 3DExperience Catia, and ArcGIS software.

The innovation of 7 courses - Innovated courses:

1. Technical drawing with computer graphics - innovated in the part of the course's content that refers to 3D visualization of objects according to the standards of technical drawing using 3DExperience Catia software.
2. Machines and devices - is innovated in the part of the content of the course related to the application of the MATLAB program to simulate the operation of pumps, compressors, fans, pneumatic transport systems, convective dryers with pneumatic transport of materials (Fig. 2).

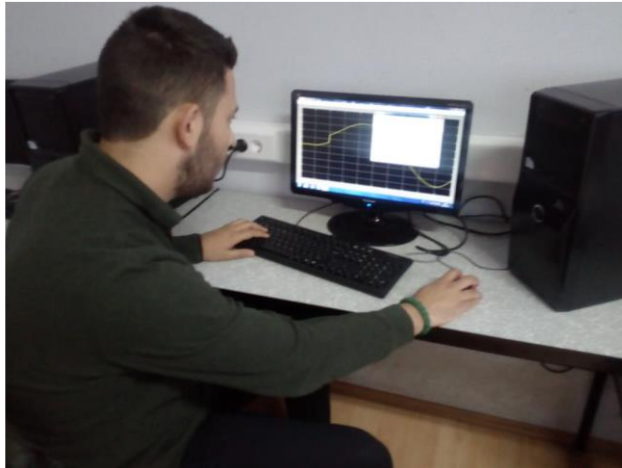

Fig. 2. Work of students in the IT lab on course Machines and devices

3. Geographic information systems - are innovated in the part of the course content related to the application of 3D approaches in layer management and 3D visualization and further development in accordance with modern technologies (Fig. 3).



Fig. 3. Work of students in the IT lab on course Geographic information systems

4. Preparation of production process - is innovated in the part of the course's content that refers to the construction preparation that deals with product design.
5. Mechanical design CAD/CAM - innovated in the part of the course content using 3DExperience Catia software.
6. Industrial geology - is innovated in the part of the course content related to the application of GIS programs for obtaining the necessary knowledge in the collection, systematization, generalization and analysis of geological-geophysical information for geological study of deposits.
7. Automatic control - is innovated in the part of the course content related to the application of the software tool MATLAB Simulink for all thematic units of the course.

Organizing knowledge testing - a total of 10 new colloquia were organized within the courses covered by the project.

Surveying - one survey was conducted with teachers and associates and one survey with students involved in the project on the project's satisfaction. Based on the results of the student survey on attitudes and opinions on job satisfaction on the project, which are presented graphically in Figure 4, it can be concluded that the quality of the project was rated with an excellent average score of 4.56 [4.]

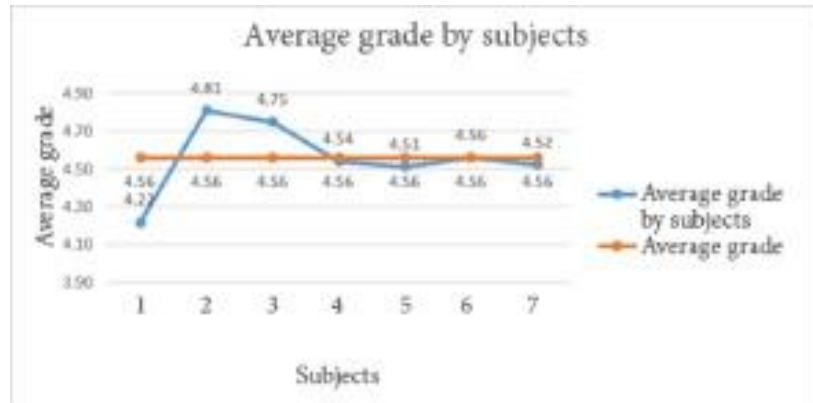

Fig. 4. Graphic presentation of the results of the student satisfaction survey for all seven courses (subjects) covered by the project [4]

Promotion of the achieved results within the project "IT lab - laboratory for engineering analysis, modeling and simulation" - was realized on June 19, 2019. in the small amphitheater of the Technical Faculty "Mihajlo Pupin" in Zrenjanin.

DEVELOPING INNOVATIVE AND ENTREPRENEURIAL COMPETENCIES OF FUTURE ENGINEERS

In a fast-changing, interconnected world, education must change to prepare students for success in life. The world economy pays you for what you can do with what you know. Nations that want a knowledge economy are investing to produce students who can intelligently manage and evaluate information and data. They are moving beyond asking whether students can reproduce what they learned in school. They want to know how creatively they can use what they know, and whether they can extrapolate from it and apply their knowledge in another context. Skills such as critical thinking, creativity, problem solving, and collaboration are at an increasing premium [5].

It is well known that engineers and technical staff create national income. It is also known that finalization of studies is a necessary but not sufficient condition for incorporation in the economic development. Namely, the sense of engineering is problem solving, so the essence of engineering education is learning how to pose a problem and learning how to solve a problem. So, efficient studies develop both problem posing and problem solving skills [6].

In the project [7], through the research of students' entrepreneurial readiness in Serbia, it is pointed out the necessity of organizing academic courses at all higher education institutions, especially on engineering technical - technological profiles. The idea is to check the connection between specific characteristics of students and their readiness for entrepreneurship.

The study program Mechanical Engineering, within which the IT lab - laboratory for engineering analysis, modeling and simulation project was conducted, largely gives entrepreneurial competencies to graduate students, especially due to the importance of mechanical products in all spheres of life and work.

Considering that great importance has been attached to the development of entrepreneurship in recent years, the IT - lab - laboratory for engineering analysis project has enabled students to be trained in the skills they need and be able to design, construct and make a finished product, machine or device. The

application of appropriate software enables the design and simulation of the operation of simple machine parts to complex production plants.

Thus, students acquired clear entrepreneurial competencies because they can realize digitalized technical preparation from technical sketches through workshop drawings to the virtual design of machines and devices and predict their behavior at work based on given conditions.

The realization of the IT lab project - laboratory for engineering analysis, modeling and simulation is a step towards encouraging entrepreneurial competencies by encouraging a faster transition from mass production of low-value products to products with higher added values, i.e., products that are typically related to knowledge, advanced technological capabilities, and highly specialized skills.

In the study programs, Information Technology in e-Government and Industrial Engineering in Oil and Gas Exploitation, which are also included in this project, IT - lab - laboratory for engineering analysis, modeling, and simulation largely provides entrepreneurial competencies in the development and development of necessary GIS database for use in the economy in accordance with the relevant field of activity.

CONCLUSION

For the application of the dual principle in the modernized system of secondary and higher vocational education in Serbia, it will be crucial to attracting employers and companies, as well as the introduction of support mechanisms to ensure the quality of the learning process in both learning environments.

The dual program is a program for students who can and want to study seriously and who are willing to invest in their promising professional career through good work. What the student gets the most is self-confidence and the development of responsibility for independently creating their future.

With the launch of the IT - lab project, opportunities were created to raise the faculty to a new and modern technological level. Students were given the opportunity to more easily and better master the courses covered by the project by applying the improvements made possible by modern software packages and improved access to courses. In this way, conditions were created for faster and more efficient results in the fields of research, development, and testing of new products, which further opens the possibility for the laboratory to include entities from the local community and beyond (businesses, government institutions, high schools). etc.) to work on joint educational, research, and development projects.

Gratitude: The research results presented in this project are part of the project "IT lab - laboratory for engineering analysis, modeling and simulation," funded by the Ministry of Education, Science and Technological Development within the program activity "Development of higher education" 2018/2019, under number 451-02-02733 / 2018-06. Members of the project team: Ph.D Dragica Radosav, Dean, Project Manager; Ph.D Eleonora Desnica, member; Ph.D Slavica Prvulović, member; Ph.D Ljiljana Radovanović, member; Ph.D Jasmina Pekez, member; Ph.D Vladimir Šinik, member; MSc Ivan Palinkaš, member.

REFERENCES

- [1] Dualno srednje stručno obrazovanje u Srbiji - Studija izvodljivosti, GIZ, 2015., <http://www.pks.rs/SADRZAJ/Files/Centar%20za%20edukaciju/GIZ%20VET%20-%20Dualno%20obrazovanje%20STUDIJA%20Srpski%20WEB%20s2.pdf>
- [2] Desnica, E., Vulić, M., Education of the 21st century in the function of ability improvement and engineering competence, International conference Inovaeducation 2018, September, Novi Sad, pp. 129-139, 2018.
- [3] Radosav, D., Desnica, E., Pekez, J., Unapređenje nastave kroz projekat IT lab (laboratorija za inženjersku analizu, modeliranje i simulaciju), IX Naučno stručni skup Preduzetništvo, inženjerstvo i menadžment PIM9, Zrenjanin, 2020., (paper accepted)
- [4] Radosav, D., Palinkaš, I., Pekez, J., Desnica, E., Radovanović, Lj., Prvulović, S., Šinik, V., Tehnički izveštaj (sa priložima), Tehnički fakultet „Mihajlo Pupin“, Zrenjanin, br. 01-2460, 2019.

- [5] A Practical Guide to Learning and Teaching with Technology -Transforming Education for the Next Generation, Intel education (accessed on 2019)
- [6] Okuka, A., Žigić, M., Grahovac N., Spasić, D., Efikasnost studiranja kao osnova privrednog razvoja, XXIII Skup Trendovi razvoja: "Položaj visokog obrazovanja i nauke u Srbiji", Zlatibor, 2017., Paper No.T3.2-1
- [7] Stošić Mihajlović, Lj., Mihajlović, M. Inovativne preduzetničke kompetencije studenata inženjerskog tehničko-tehnološkog profila, 3. Nacionalna konferencija sa međunarodnim učešćem Informacione tehnologije, obrazovanje i preduzetništvo, ITOP18, str. 279-288, Čačak, 2018.

INDUSTRIAL ENGINEERING METHODS AND TECHNIQUES IN INDUSTRY 4.0

Mirjana Misita¹, Vesna Spasojević Brkić¹, Dragan D. Milanović¹, Martina Perišić¹

¹University of Belgrade, Faculty of Mechanical Engineering, Belgrade, Serbia

e-mail: mmisita@mas.bg.ac.rs

Abstract: The paper analyzes the importance of the application of methods and techniques of industrial engineering in the business environment of Industry 4.0. Survey done indicates that in the new business environment, the methods and techniques of industrial engineering come to full expression because cyber-physical systems give a complete insight into the nature of production processes. Accordingly, an example of an IE method application and ways of its integration in I4.0 environment is given and discussed.

Key words: industrial engineering, industry 4.0.

INTRODUCTION

Industry 4.0 - a new business philosophy of the factories of the future is a concept made possible by connected elements: the internet, machines and people. In such an environment, computers communicate and process large amounts of data using artificial intelligence. The system consists of autonomous systems, cyber physical systems, sensors, robots, smart machines, people, and the whole concept from the point of view of business management allows understanding what happens in the production process. Detailed insight into the nature of functioning of production processes allows to make better decisions about planning, scheduling, strategic planning, maintenance, production efficiency, quality, etc. In that sense it can be spoken Management 4.0, Logistics 4.0, Supply Chain 4.0, Maintenance 4.0. The whole philosophy of business is changing, approaching business from a different aspect, which opens up numerous possibilities.

INDUSTRIAL ENGINEERING METHODS IN I4.0

In environment Industry 4.0, we have the opportunity to really manage business and production processes. So far, we have had input data and output data, we have changed the input data to get the desired output according to the feedback principle. Each business-production process represented the so called a black box because there was no information from the production itself. Industry 4.0 enables the storage of a large amount of data on the very characteristics of business and production processes thanks to sensors, Internet of Things (IoT), Big Data, Cloud Technology. I4.0 technology allows permanent storage of many data/characteristics of all relevant factors (such as temperature, vibration, pressure, but also downtime, bottlenecks, failures, etc.) that allow insight into the flow of production processes, operations, movements, materials, energy, human resources and all other available resources. By applying Data Analysis concept from a multitude of stored data (where there are good data, but also there are so-called messy data (unclear type different form, wrong entry, etc.) and some data that are unusable) using appropriate techniques cleans data and extracts good data for further analysis. Data analysis includes:

- descriptive analysis – what happened,
- predictive analysis – what should happen,
- prescriptive analysis – what we would like to happen.

Furthermore, different industrial engineering methods and techniques can be applied in factories depending on the goal of the company to be achieved. The application of these methods and techniques of industrial engineering enables the increase of business efficiency, maintenance, quality, management, etc. [1-4].

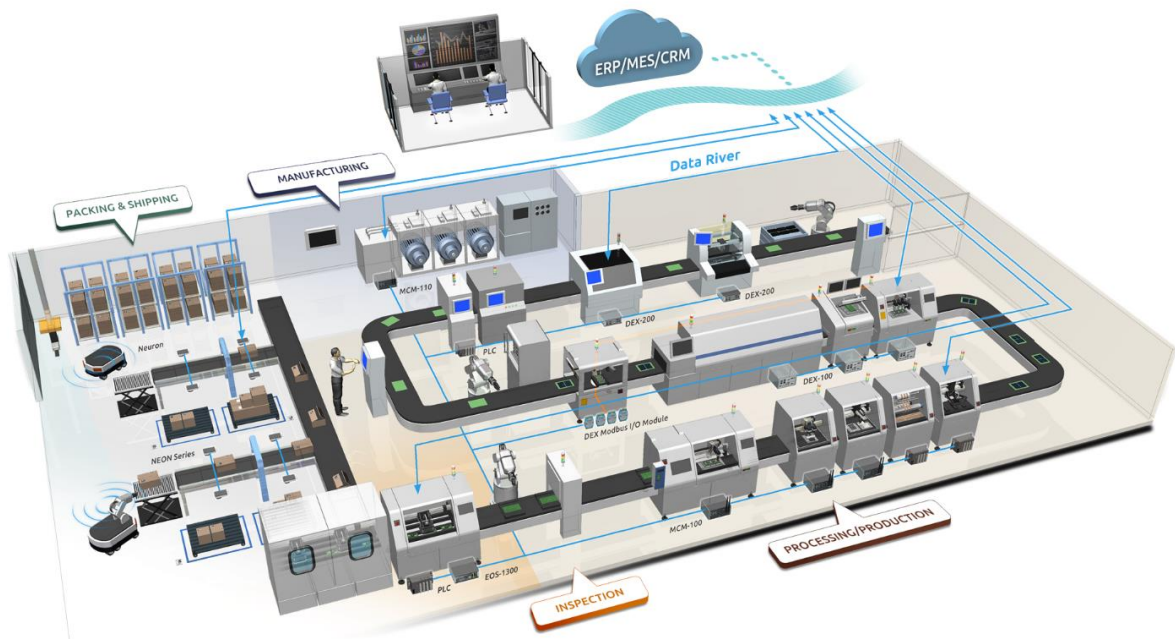

Fig. 1. Smart factory [5]

For example, in I4.0 environment, when there are the above data from the Cloud, it can be applied different methods of planning, scheduling, SWOT, TMP, SKK, BSC, failure structure, bottlenecks in the production process, methods of optimization of production processes [6]-7]. Decisions can be made based on data from the production process itself, and not after the end of the production cycle. It means that costs and production cycle times can be minimized. Until now, unit costs of production precisely because of the lack of information within the production process have always been unknown. Also, Lean production can be adequately applied according to Toyota's concept, in which the consumption of all production resources is reduced to a minimum while maintaining product quality, exactly on time (JiT concept) and with minimal wastes [8-11]. That is, everything that is set as target criteria for optimizing production processes, in environment I4.0 is enabled to be applied thanks to the concept that provides insight into the production process itself, as well as the ability to manage systems in such an environment.

The application of artificial intelligence (AI) in the I4.0 environment has several domains: the first segment refers to the application of AI over a large amount of data for the purpose of descriptive analysis [12-15]. For example, machine learning as a tool for observing patterns of behavior and for predicting behavior in further work. Then, AI is used in the process of making decisions about further activities, planning, forecasting, strategy development, implemented in knowledge support systems based on knowledge, expert systems, artificial neural networks and the like. AI is also used to design algorithms for the operation of systems in IoT environment in order to express their synchronized effect.

The next aspect that should be mentioned is that the employee is freed from repetitive tasks, then tasks that represent a risky job, hazardous substances, etc. which improves the position of the employee in the I4.0 environment because it reduces the risk and possibility of injury at work, and on the other hand, employees are more engaged in creative and innovative work.

Also, collaboration in stable, reliable supply chains, based on long-term partnerships are not sustainable in the circumstances of today's global economy, so, concept of remote engineering proposed in [16] could be used in aim to enhance competitive advantages and provides a fast, economical and experience sharing method for the enterprises. Industrial engineering methods are usable to overcome issues in available, common conceptions of how to measure usability [17].

It is also necessary to mention augmented reality (AR) and virtual reality (VR) as tools that allow employees to perform their work tasks. AR and VR have a large share in the design of new products, design, marketing, etc. AR enables employees to perform complex business operation more easily, it enables great diversification of the production program, adjustment of products according to the

customer's wishes. It describes systems that superimpose computer-generated information that can be multisensory, in reality seeking to improve the real environment rather than replace it [17]. VR is a computer interface that allows the user to be a part of an experimental simulation and is successfully applied in many branches of the manufacturing industry [18].

Methods and techniques of industrial engineering of production processes applied in I4.0 in order to achieve greater business efficiency can be applied through:

- logical functions,
- production rules, network rules,
- decision tree,
- knowledge base,
- conditional formatting,
- statistical analysis, correlation, regression, factor analysis,
- multi-criteria decision making, etc.

For example, data stored in the cloud can be used for FMEA analysis (Failure Mode and Effects Analysis). FMEA analysis can be generated in the form of SQL queries, and plans and action measures for risk mitigation in the form of a knowledge base. In this way, by applying the generated module for FMEA analysis in I4.0, we are enabled online monitoring of failures and preventive maintenance of machinery, thus reducing maintenance cost and increasing the efficiency of the machinery maintenance process.

Table 1. Example SQL query for FMEA analysis

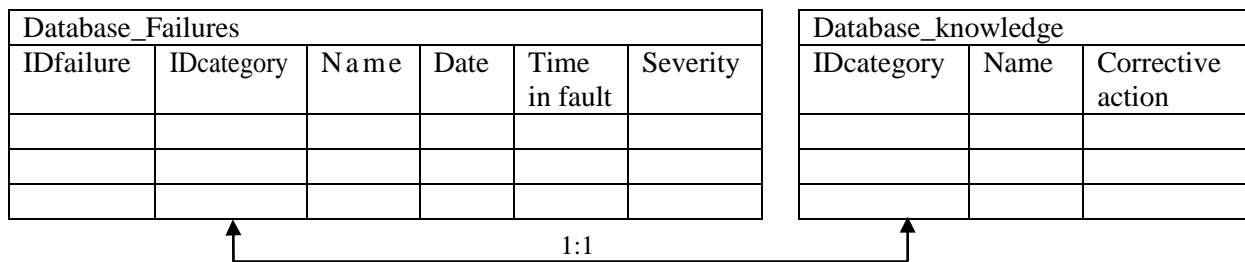

```
SELECT *
FROM Database_failures
LEFT JOIN Database_knowledge ON
Database_failures.IDcategory=Database_knowledge.IDcategory
ORDER BY Database_failures.IDfailure
```

```
SELECT
Database_failures.IDfailure,
Database_failures.IDcategory,
COUNT(database_failures.IDfailure) AS Failure_Frequency,
Database_failures.Failure_Frequency * Database_failures.Failure_Frequency.Severity AS RNP
FROM Database_failures
LEFT JOIN Database_knowledge ON
Database_failures.IDcategory=Database_knowledge.IDcategory
GROUP BY database_failure.IDCategory
ORDER BY RNP DESC
```

Above query gives as calculation of Risk Priority Number for determination order of application corrective measures for maintenance of observed machine.

I4.0 also characterizes the introduction of cyber-physical systems that are reflected in the use of smart devices (sensors, actuators). A smart device is a machine with the properties of a computer. One of its main features is the ability to communicate with other smart devices in the environment (data transmission) and perform smart operations.

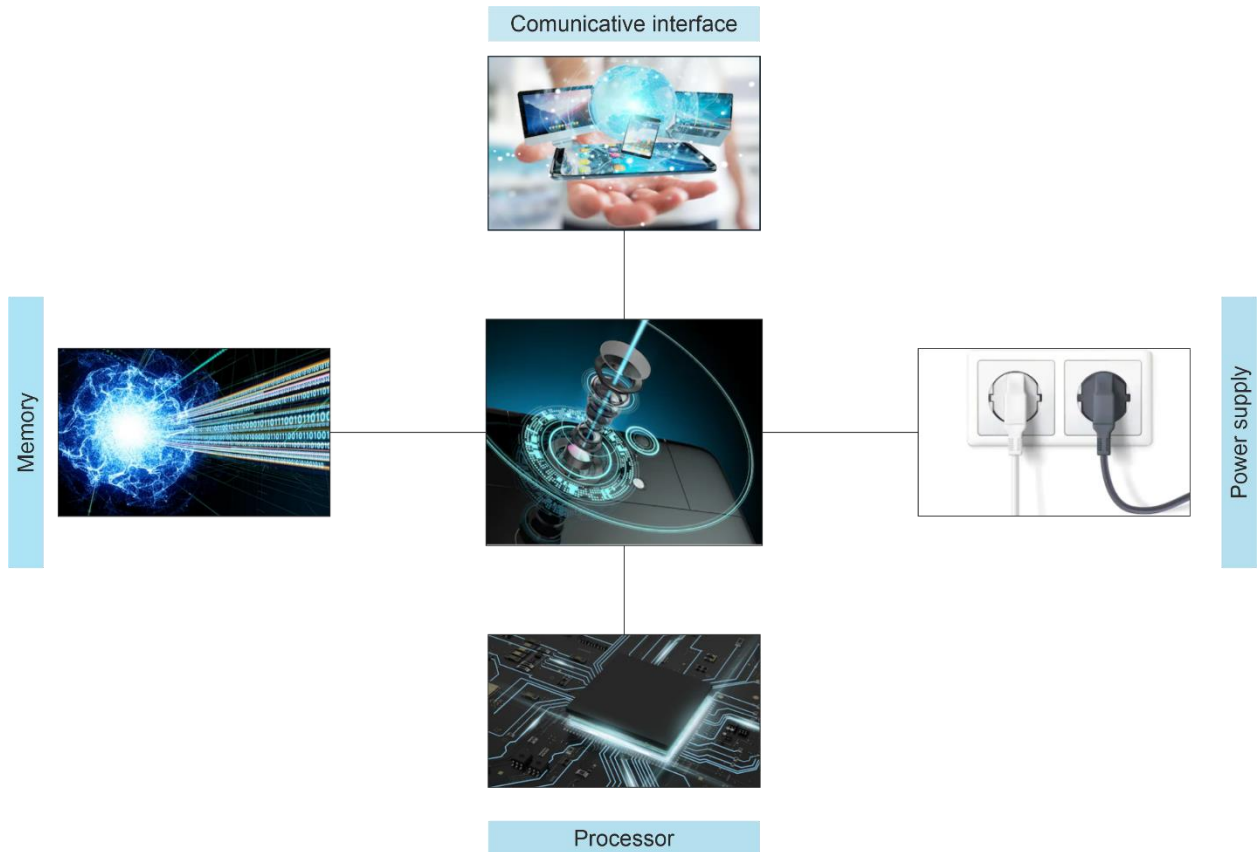

Fig. 3. Smart sensor

One smart device must have a power supply, memory, processor and communication interface. What needs to be satisfied from the aspect of business production industry are, first of all, low prices and low energy (Machine to Machine – M2M) of these devices. Figure 3 shows smart sensor, and Figure 4 shows smart actuator.

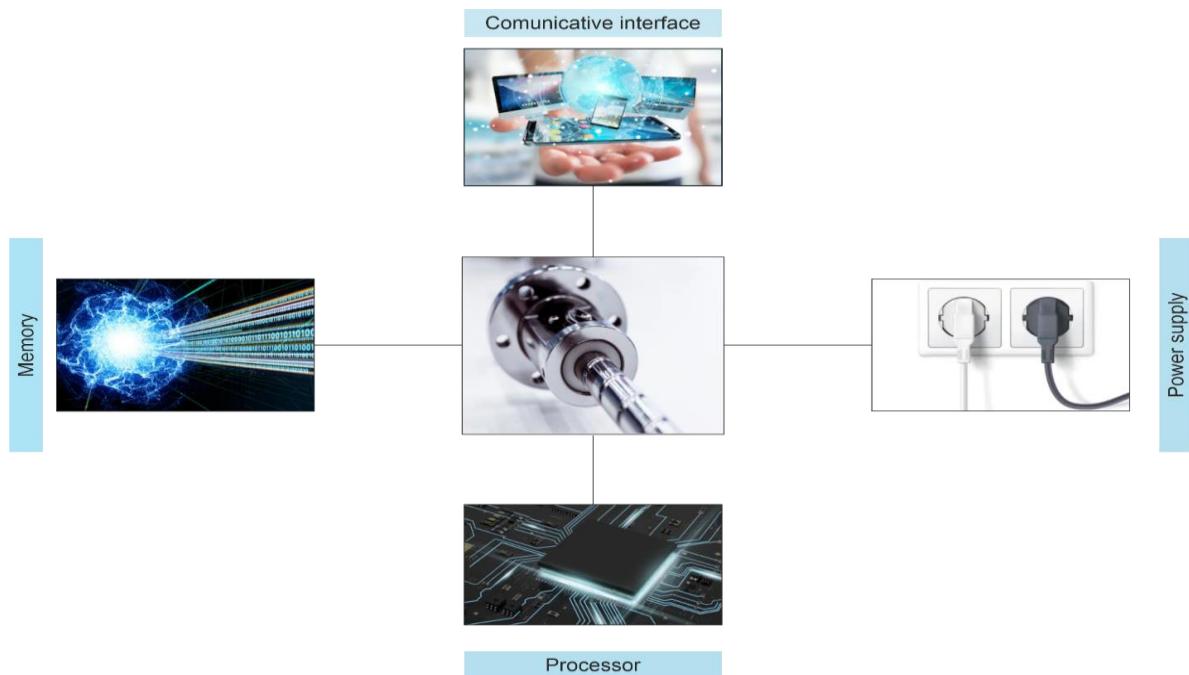

Fig. 4. Smart actuator

Presented model of integration of industrial engineering methods and techniques enables online monitoring of production process influence factors, and also enables increasing productivity and efficiency of the business production systems. Also, according to our previous results employees' behavior has to be in accordance with technological level – as in [18] upgrading of technological levels forces employment of proactive people with soft culture.

CONCLUSION

In a new business environment dominated by smart machines, the applied method and technique of industrial engineering can point to the internal potentials of manufacturing companies. Methods and techniques of industrial engineering are aimed at optimizing production processes, better utilization of available resources, reducing downtime and waste, more efficient production management and increasing profitability. In Industry 4.0, these methods and techniques implemented come to full expression as networking and communication between cyber-physical systems is raised to a higher level.

Future researches should be focused on implementing of presented model of integration of industrial engineering methods and techniques in the industry. Also, the research can be focused on employees and their satisfaction by implementing I4.0 in production factories, then how the implementation of the presented model can affect on workplaces.

ACKNOWLEDGEMENT

This paper is supported by grants from the Ministry of Education, Science and Technological Development, grants from project E113300 and contract 451-03-68/2020-14/200105 (subproject TR 35017).

REFERENCES

- [1] Barreto, L., Amarala, A., Pereira, T. "Industry 4.0 implications in logistics: an overview", MESIC, Vigo (Pontevedra), Spain, 2017.
- [2] Lolli, F., Balugani, E., Ishizaka, A., Gamberini, R., Rimini, B. A., Regattieri, Machine learning for multi-criteria inventory classification applied to intermittent demand, *Production Planning & Control*, 30 (1) pp. 76-89, 2019.
- [3] Moeuf, A. Pellerin, R. Lamouri, S. Tamayo-Giraldo, S. Barbaray, R., The industrial management of SMEs in the era of Industry 4.0, *International Journal of Production Research*, 56 (3), pp. 1118-1136, 2018.
- [4] Pereira, M.T., Silvaa, A., Ferreira, L.P., Sá, J.C., Silva, F.J.G., A DMS to Support Industrial Process Decision-Making: A Contribution Under Industry 4.0, *Procedia Manufacturing*, Vol. 38, pp. 613-620, 2019.
- [5] Adlink - Leading Edge Computing, Meet your Factory of the Future, https://www.adlinktech.com/cn/Smart_Manufacturing, Accessed on: September, 2020.
- [6] Bueno, A., Filho, M.G., Frank, A.G., Smart production planning and control in the Industry 4.0 context: A systematic literature review, *Computers & Industrial Engineering*, Vol. 149, 106774, 2020.
- [7] Ivanov, D. Dolgui, A. Sokolov, B. Werner, F. Ivanova, M., A dynamic model and an algorithm for short-term supply chain scheduling in the smart factory industry 4.0, *International Journal of Production Research*, 54 (2) pp. 386-402, 2016.
- [8] Liker, J. K., Don't Count Humans Out: At Toyota, classic industrial and systems engineering keeps industry 4.0 from taking manufacturing away from reality. (Cover story). *ISE: Industrial & Systems Engineering at Work*, Vol. 50, n. 8, pp. 28–33, 2018.
- [9] Oliveira, J. Sá, J.C. Fernandes A. , Continuous improvement through "Lean Tools" – An application in a mechanical company, *Procedia Manufacturing*, Vol. 13, pp. 1082-1089. 2017.

- [10] Pekarcikova, M., et al. Material Flow Optimization through E-Kanban System Simulation. *International Journal of Simulation Modelling (IJSIMM)*, Vol. 19, n. 2, pp. 243–254, 2020.
- [11] Rossit, D.A., Tohmé, F., Frutos, M., Industry 4.0: Smart Scheduling, *International Journal of Production Research*, Vol. 57 (12) pp. 3802-3813, 2019.
- [12] Rossit, D.A., Tohmé, F., Frutos, M., Production planning and scheduling in cyber-physical production systems: A review, *International Journal of Computer Integrated Manufacturing*, 32 (4–5), pp. 385-395, 2019.
- [13] Sackey, S. M.; Bester, A.; Adams, D. Q. A Framework for an Industrial Engineering Learning Facility Paradigm toward Industry 4.0. *South African Journal of Industrial Engineering*, Vol. 31, n. 1, pp. 122–132, 2020.
- [14] Wuest, T. Smart manufacturing builds opportunities for ISEs: Engineering expertise is needed to manage challenges posed by Industry 4.0 innovations. *ISE: Industrial & Systems Engineering at Work*, Vol.51, no. 4, pp. 40–44, 2019.
- [15] Spasojević-Brkić, V., Putnik, G., Shah, V., Castro, H. and Veljković, Z., Human-computer interactions and user interfaces for remote control of manufacturing systems. *FME Transactions*, 41(3), pp.250-255, 2013.
- [16] Brkić, V.K.S., Putnik, G.D., Veljkovic, Z.A. and Shah, V., Interface for distributed remote user controlled manufacturing: manufacturing and education sectors led view. In *Handbook of Research on Human-Computer Interfaces, Developments, and Applications*, pp. 363-391, IGI Global, 2016.
- [17] Doil, F., Schreiber, W., Alt, T., & Patron, C., Augmented reality for manufacturing planning. In *Proceedings of the workshop on Virtual environments*, pp. 71-76, 2003, May.
- [18] Moeuf, A. Pellerin, R. Lamouri, S. Tamayo-Giraldo, S. Barbaray, R., The industrial management of SMEs in the era of Industry 4.0, *International Journal of Production Research*, 56 (3), pp. 1118-1136, 2018.
- [19] Brkic, V.K.S., Veljkovic, Z.A. and Petrovic, A., Industry 4.0 technology and employees behavior interaction in serbian industrial companies. In *International Conference on Applied Human Factors and Ergonomics*, pp. 94-103, Springer, Cham, 2019, July.

PROCEDURE DEVELOPMENT OF FLIP STATION FOR POSITING DISC AND ROTOR TYPE PARTS

Miroslav Milutinović¹, Spasoje Trifković¹, Aleksija Đurić¹

¹University of East Sarajevo, Faculty of Mechanical Engineering, East Sarajevo,
Republic of Srpska, B&H

e-mail: miroslav.milutinovic@ues.rs.ba

Abstract: The rapid progress of automation, functional requirements and requirements for the shortest possible assembly times of machine parts also require the development of various constructions solutions that serve to help solve various problems in manufacturing flows. Through this work presents the clearly defined steps from the idea, or the list of requirements that are defined by the customer to the final constructions (workstation). Based on the list of requirements, a conceptual solution was formed, on the basis of which they developed shapes and dimensions of a workstation, with a clearly indicated division of manufactured or purchased parts. In the end, after various analyzes, documentation was prepared on the basis of which a constructions solution was made. Based on customer requirements, sensors and cameras were used to detect the position of parts.

Key words: design workstations, sensors, automation

INTRODUCTION

The lack of manpower, as well as the acceleration of the production process, also caused an increase in the degree of automation. Daily increases the number of robots that replace human labor in different spheres of mechanical industry. There are many examples of automation in the automotive industry [1]. In addition to the many possibilities of robot operation, there is a need for automated auxiliary stations that complete the system and lead to process balancing [2-3]. Depending on the production process, the function will depend, as well as the construction of those stations. The development of an independent and automated station creates the basis for its inclusion in a fully automated system or system based on industry 4, which can be developed in several ways [4].

Through this paper, the procedure of development of one station is presented, for positioning two different machine parts, which are placed on that station by a robot, then taken and carried on to other stations. This procedure covers the entire process from the idea, ie the requirements of the table, the requirements of the production line, but also the limitations from the aspect of robotics to the construction of a structure that meets all these requirements. At the very beginning, there is always the question of quality, price, speed of change, as well as the position of the intermediate station between two workstations where the transport of the machine part from one to another requires changing the position ie rotation of the parts. Changing the position of the part opens up new potential problems. One of them can be the way of positioning and fixing the part, as well as the coordination between the object that puts and takes over the part from the table. Complete coordination should be coordinated and monitored by sensors. This is one of the essential requirements that must be defined from the very beginning. There are several ways in which the development path from idea to realization can be defined.

DEFINITION OF REQUIREMENTS AND CONCEPTS

There are a number of requirements that must be met when designing a construction for positioning disc and rotor type parts. These requirements can be divided into two types, namely the requirements that the constructions must meet in relation to the disk and the requirements related to the rotor. Both development paths must go through the same procedure defined in Figure 1.

There are two ways to develop this construction. The first is the individual (separate) development of the constructions, which refers to the parts of the disk type and the parts of the rotor type, and subsequently define the elements of the connection between these two constructions. Another way is to develop both constructions together and parallel.

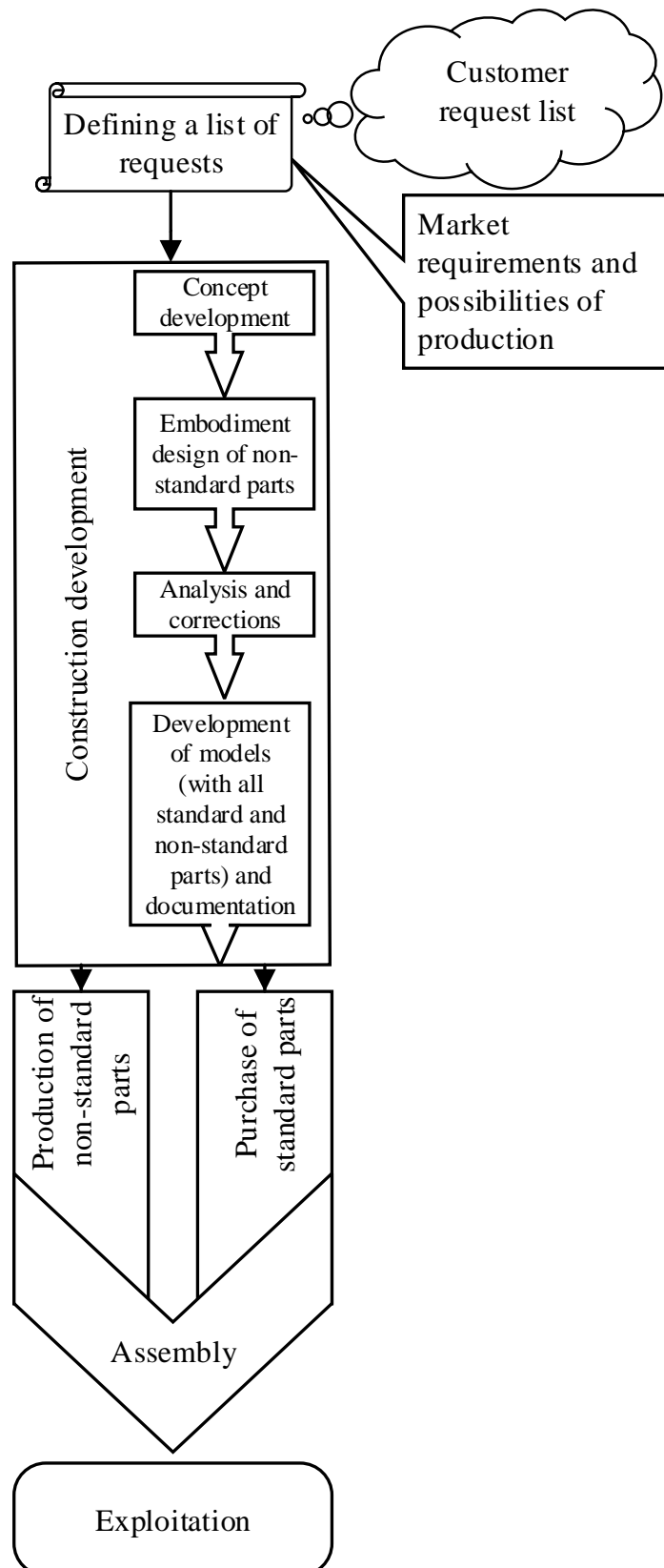

Fig. 1. Display of workstation development from idea to finished product in the process of exploitation

The requirements that must be met related to the disk are:

- The disc should be positioned at a height between 800 and 1000 [mm];

- The robot must have access to the part from both sides, ie it can be put from one side, from the side from which it was taken from the conveyor, and taken from the other side;
- The part must be clearly and unequivocally positioned each time you leave and take the part;
- The part must always be in the same position when the robot picks it up from the station;
- The coordination of the robot grips with the workstation must be harmonized;
- The robot can only catch the part by a cylindrical surface on which there is a rough finish (clearly defined area);
- Part detection must be performed;
- The construction must have a load capacity of at least 12.5 [kg];
- The sensors used to detect the part must be from the IFM manufacturer;
- If parts detection cameras are used, they must be from the Keyence manufacturer;
- If a motor is used to rotate the bearing parts, it must be from the FESTO manufacturer,...

Requirements set in relation to the rotor can be defined as:

- The construction must provide clear and unambiguous positioning of the part;
- The position of the part must be detected;
- The robot must have unobstructed access to the station when installing and removing the part;
- The sensors used to detect the part must be from the IFM manufacturer;
- If parts detection cameras are used, they must be from the Keyence manufacturer;
- Height to be between 850 and 950 [mm];
- The robot can grasp the part for the cylindrical surface on which the rough processing is;
- It must be possible to access the robot rotation from several directions, if the part is not well positioned,...

Based on clearly defined requirements, a conceptual solution of the table can be formed (Figure 2) on the basis of which the shapes and dimensions of all parts will be developed. The concept was made separately for the disk type part and the rotor type part.

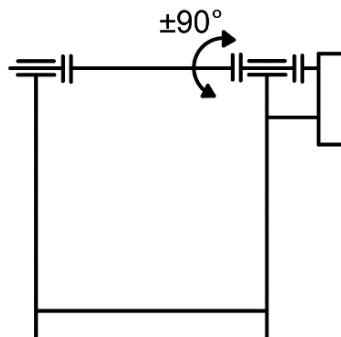

Fig. 2. Conceptual design construction for a part of the disk type

Identical, based on the requirements for the construction on which the rotor will be positioned, a conceptual solution was formed (Figure 3).



Fig. 3. Conceptual design construction for rotor type parts

On the basis of two separate concepts, it was established that the conditions for the disk and the rotor can be met on the same construction, and based on that, a conceptual solution was formed as in Figure 4.

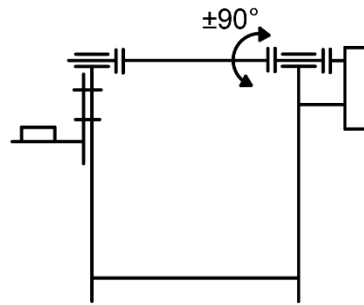

Fig. 4. Conceptual design for defined requirements for disk and rotor parts

EMBODIMENT DESIGN

In developing the shape and dimensions of machine parts, it is very important to take into account the preparation of materials from which machine parts will be made, ie care should be taken whether the material is in the warehouse (in stock) or must be ordered from suppliers. Also, another very important thing is if you purchased a semi-finished product what is the deadline and what is the price of delivery? If there are finished parts from some suppliers, and they can be delivered to the assembly plant as soon as possible and at the lowest possible prices, and they meet the requirements, such parts should be given priority over the parts that are made completely.

As the most appropriate for the production of a support constructions is a welded constructions made of a profile of square cross-section, with sheet metal fillings from the apartment, which have the function of supporting the upper load-bearing surfaces (Figure 5). According to the requirements that the robot must have access to the part on both sides, ie to "put down" the part and lower it to the workstation, and then to take the same part with the same or other grips from the station on the other side, (in Figure 6.)

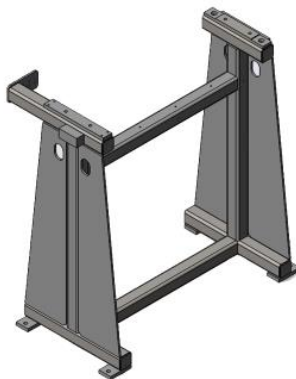

Fig. 5. Developed shape of the supporting structure

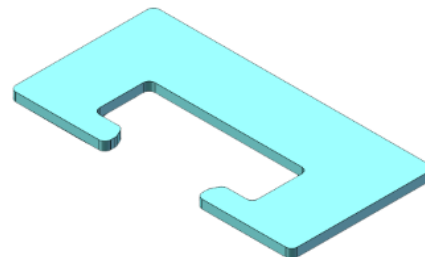

Fig. 6. Developmental shape of the support plate

On the basis of further clearly defined requirements, other parts were also developed, but standard ones that could be purchased were used, and their price was lower than the production price. All these parts are positioned on the developed support plate and fastened in an appropriate way, so that they can position the part and hold it until the robot grippers accept it (Figure 7).

The shapes and dimensions of the subassembly for rotor positioning were obtained in an identical way (Figure 8).

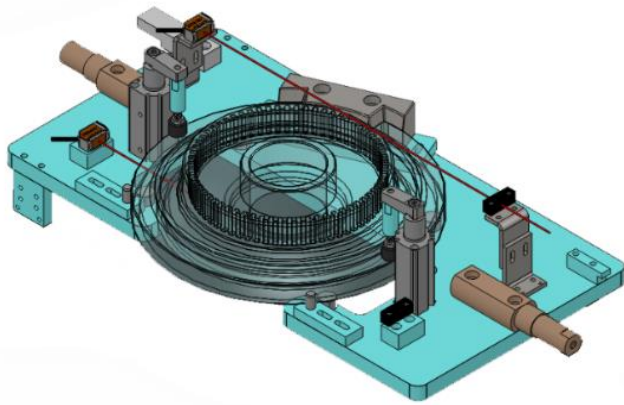

Fig. 7. Developmental shape of the support plate with all supporting elements, without screws

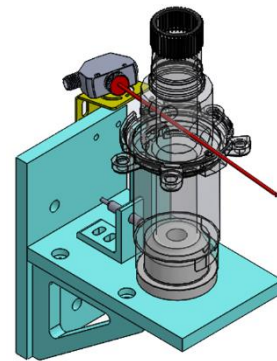

Fig. 8. Developmental form of the supporting constructions for the rotor, without screws

Taking into account all the requirements and limitations, a complete workstation assembly was developed for positioning the disk and rotor type parts (Figure 9). Figure 9a shows the construction in the position when the robot lowers the parts on the construction, while Figure 9b shows the position of the station in the position when the robot takes the parts.

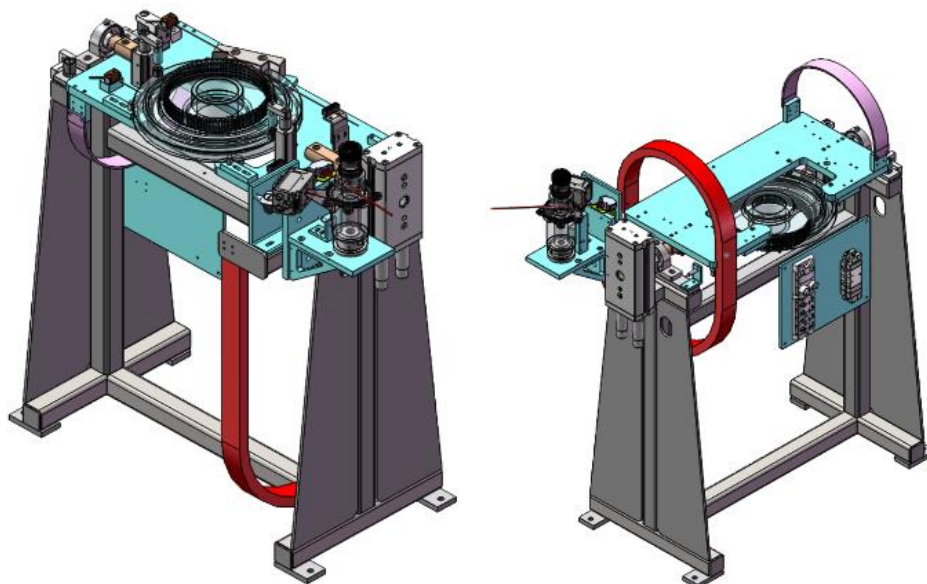

Fig. 9. Development form of a station for positioning disk and rotor type parts

ANALYSIS THE WORKING OF CONSTRUCTION

By analyzing the work of the construction, it can be concluded that the disk together with the carrier plate rotates by an angle of 180° , while the rotor is only positioned in a certain position, so that the robot can be programmed to take it from the appropriate side and bring it to the next station in a clearly defined position.

The plate is rotated using a Festo rotary actuator with a gear and a gear rack (Figure 10). The maximum allowed moment of inertia on the coupling at a pressure of 6 [bar] ranges from 1000-67000[kgcm²] for a rotation of 180° depending on the time cycle which can be from 0.5-4 [sec].

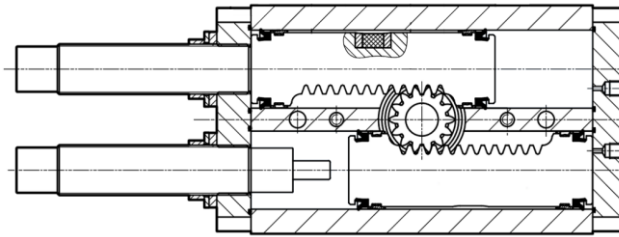

Fig. 10. Festo swivel drive with gear and gear rack

An inductive IFM short-range PNP sensor was used to detect the presence of the rotor, while a laser sensor with a range of up to 300 [mm] was used to detect the position. The position and presence of the disc is detected by two retroreflective sensors. One sensor gives a signal that the disc is placed on the board, while the other sensor checks the correct position of that disc. If both signals are positive it means that the disc is in position, which gives a signal that the grippers can clamp the disc and that the plate can be rotated by 180°. When the disk is brought to the position to be on the lower side of the board, it is necessary to keep it in a precisely defined position with appropriate grips which will release it and allow the robot to take it over when the robot accepts the disk. This is made possible by the use of rotating grippers. In order to be able to rotate the table, two bearings with ball bearings were used, and in order to stop the plate each time in the same position, an additional inductive sensor and small shock absorbers were used. An additional sensor detects the position of the board and based on it, a signal is obtained from which side of the board the robot should approach the table.

DEFINITION OF STANDARD AND NON-STANDARD PARTS

The next step, after the developed model, is the preparation of documentation for each non-standard part on the basis of which the production is performed. Figure 11 shows a complete model with some of the positions and parts that are made. In addition to the parts that are made, it is necessary to use standard components so that the assembly can function and perform its function.

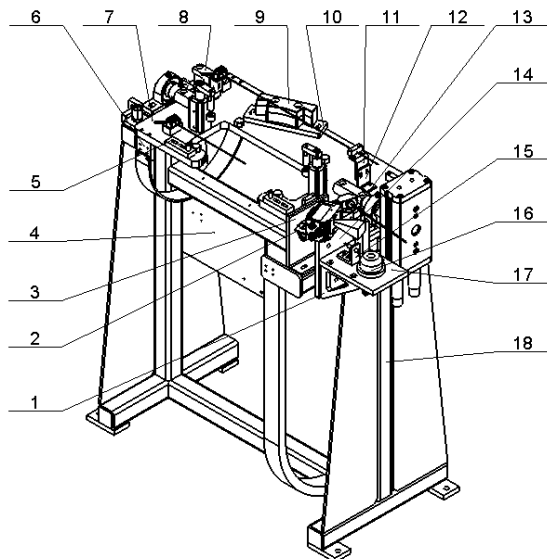

Fig. 11. Isometric view of the model with some of the positions and parts that are made.

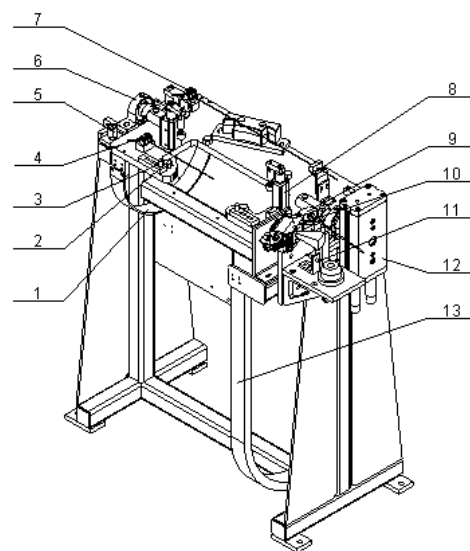

Fig. 12. Isometric view of the model with some of the positions of the standard parts

Figure 12 shows a view of the model, which defines some of the standard components that are ordered from the manufacturer and together with the parts made in the production plant are assembled into one assembly.

CONCLUSION

On the basis of the customer's request and the possibilities of the contractor's production plant, ie the workshop, a wish list was defined on the basis of which the analysis and making a sketch, ie the concept of how the workstation will work, was approached. After that, an audit is performed with the client and obtaining approval to develop the shape and dimensions for each component. With the development of components, a complete assembly of the workstation with all standard and non-standard parts was made, after which a meeting with the customer was scheduled again in order to obtain the consent for the developed station. This document is the basis for further development of documentation and procurement of standard components. After all the previously defined steps and the production of parts, a construction was made on which the test was performed together with the customer. The development of this station is one of the basic steps for the analysis of the robot's operation and the development of grips with which the robot will carry the disk and the rotor.

REFERENCES

- [1] Kulkarni, A. A, Dhanush, P, Chetan B S, Thamme Gowda C S, Shrivastava, P. K. Recent Development of Automation in Vehicle Manufacturing Industries, International Journal of Innovative Technology and Exploring Engineering, Volume-8, Issue-6S4, April 2019. pp.410-413, 2019.
- [2] Sagwekar, A., Rajhans, N. R., Hans, N. Workload balancing of assembly line in an automobile manufacturing industry, International conference on manufacturing Excellence, At Nasik, 2019.
- [3] Kern, W., Rusitschka, F, Kopytynski, W., Keckl, S., Bauernhansl, T. Alternatives to assembly line production in the automotive industry, 23rd International Conference on Production Research, 2015.
- [4] Gong, L., Zou, B., Kan, Z. (2019) Modeling and Optimization for Automobile Mixed Assembly Line in Industry 4.0, Journal of Control Science and Engineering Volume 2019.

MODERN SWARM-BASED ALGORITHMS FOR THE TENSION/COMPRESSION SPRING DESIGN OPTIMIZATION PROBLEM

Mića Đurđev¹, Eleonora Desnica¹, Jasmina Pekez¹, Milošević Mijodrag²,
Dejan Lukić², Borivoj Novaković¹, Luka Đorđević¹

¹University of Novi Sad, Technical Faculty “Mihajlo Pupin”, Zrenjanin, Serbia

²University of Novi Sad, Faculty of Technical Sciences, Department for Production Engineering, Novi Sad, Serbia

e-mail: mica.djurdjev@tfzr.uns.ac.rs

Abstract: The scientific literature is enriched with large number of optimization problems of various levels of difficulty. Constrained optimization tasks in the field of engineering design have grown very popular in the last years and many authors have implemented different algorithms in order to obtain optimal solutions. One of the well-known engineering optimization problems is so-called tension/compression spring design. Several novel and very popular swarm-based intelligent algorithms are implemented in this study in order to minimize weight of the string and to obtain comparative results. Graphical representations of convergence curves as well as statistical results have been also included in this brief study. Swarm-based algorithms performed well and fast for the tension/compression design problem.

Key words: swarm-based algorithms, spring design, optimization, metaheuristics

INTRODUCTION

Optimization may consider a number of different problems whose complexity mostly depends on the forms of objective functions and its constraints [1]. Optimization problems can be found in many areas of engineering and industry and can be classified in different ways which requires different optimization techniques to solve them. Engineering design problems are one of the well-studied constrained optimization problems that typically consider minimization or maximization of objective functions by finding appropriate values of design variables (design parameters) according to the set of specific constraints [2]. Real-world design problems may include a large number of these variables and also a number of different linear or non-linear constraints which increase complexity when making function evaluations. In that sense, efficient and flexible optimization techniques are required.

To deal with constrained optimization problems in engineering design a number of different metaheuristic algorithms have been proposed. According to [3], metaheuristic algorithms can be grouped in three main categories, evolutionary, physics-based, swarm-based and human-based group, such as represented in Fig.1. The first group of techniques is inspired by natural evolution principles. The second one imitates physical processes that can be found in our universe. The third group of algorithms is inspired by social behavior of animals and creatures in the nature. The last group covers human-based solutions that imitate human behavior in various activities.

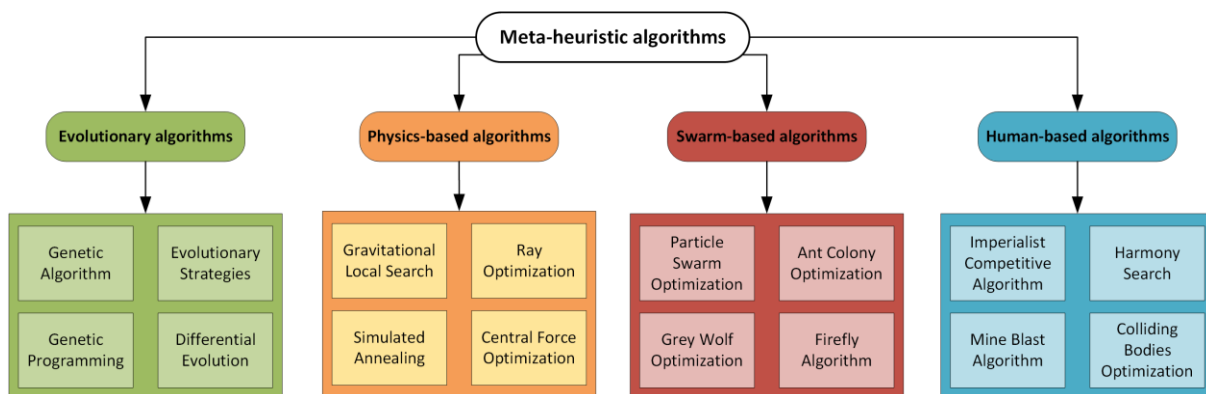

Fig. 1. A classification of metaheuristic algorithms

The emphasis in this paper will be placed on the third group of metaheuristic algorithms which are studied and introduced within the scientific field called Swarm intelligence. Swarm-based metaheuristics are population-based algorithms where a randomly generated population of individuals (potential candidates) cooperate among each other and statistically over generations become better and better and ultimately they are able to find good enough (satisfactory) solutions for a problem at hand [4]. Using a set of specific rules, swarm-based algorithms define the position vector and change it over iterations. This is achieved in two main phases, exploration, in which algorithm performs abrupt changes to ensure different regions of search space are checked, and exploitation where algorithm directs search around the best possible solutions found so far [5]. Exploitation improves local search capabilities, while exploration leans towards global search. The main advantages of these stochastic techniques are problem independence, simplicity of understanding and implementation, and adaptability to difficulties of real-world problems.

In that sense, several swarm-based metaheuristics will be employed to solve the optimization problem from engineering design called tension/compression string design problem. Comparative results will be obtained in order to show performances of the proposed algorithms and ultimately, proposals for algorithm adjustments, improvements or modifications will be highlighted.

THE TENSION/COMPRESSION STRING DESIGN PROBLEM

The tension/compression string design problem was firstly introduced in [6,7]. Objective function for this optimization task is to minimize the weight of the tension/compression string which is shown in Fig. 2 and Fig. 3. The optimal design of the spring must satisfy constraints on minimum deflection, shear stress, surge frequency and limits on outside diameter and decision variables [8]. Three continuous decision variables are taken into account: wire diameter (d or x_1), mean coil diameter (D or x_2) and number of active coils (P or x_3). Mathematical formulation of the tension/compression spring design problem is given as follows [3,9,10]:

Decision variables:

$$\vec{x} = [x_1, x_2, x_3] = [d, D, P] \quad (1)$$

Minimize:

$$f(\vec{x}) = (x_3 + 2)x_2x_1^2 \quad (2)$$

Subject to inequality constraints:

$$g_1(\vec{x}) = 1 - \frac{x_2^3x_3}{71785x_1^4} \leq 0 \quad (3)$$

$$g_2(\vec{x}) = \frac{4x_2^2 - x_1x_2}{12566(x_2x_1^3 - x_1^4)} + \frac{1}{5108x_1^2} \leq 0 \quad (4)$$

$$g_3(\vec{x}) = 1 - \frac{140,45x_1}{x_2^2x_3} \leq 0 \quad (5)$$

$$g_4(\vec{x}) = \frac{x_1 + x_2}{1,5} - 1 \leq 0 \quad (6)$$

Bound range:

$$0,05 \leq x_1 \leq 2,00 \quad (7)$$

$$0,25 \leq x_2 \leq 1,30 \quad (8)$$

$$2,00 \leq x_3 \leq 15,0 \quad (9)$$



Fig 2. Tension/compression spring schematic 2D representation [9,10]

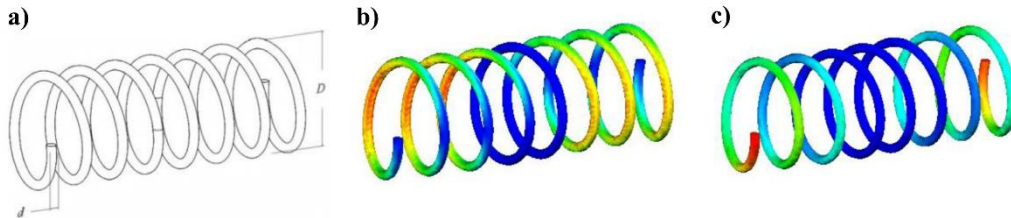

Fig 3. Tension/compression spring graphical representation: (a) 3D schematic, (b) stress heatmap (c) displacement heatmap [3]

RESULTS AND DISCUSSION

In order to obtain satisfactory results, the tension/compression string design problem has been tested using several modern swarm-based metaheuristic algorithms. Comparative results have been obtained and traditional non-modified metaheuristics have shown their performances. Among a large number of algorithms introduced in scientific community, we have adopted the following ones in this study: Crow Search Algorithm (CSA) [10], Grey Wolf Optimizer (GWO) [11], Particle Swarm Optimization (PSO) [12], Whale Optimization Algorithm (WOA) [3], Ant Lion Optimizer (ALO) [13], Bat Algorithm (BA) [14], Firefly Algorithm (FA) [15], Artificial Bee Colony (ABC) [16], Seagull Optimization Algorithm (SOA) [17] and Cuckoo Search [18]. Most of these metaheuristics are introduced in the last decade and therefore can be considered as fairly modern optimization techniques. Comparison of the statistical results obtained by the aforementioned algorithms for the tension/compression string design problem are given in Table 1. All of the metaheuristics have been run 50 times with the standard set of parameters for each. Number of iterations (1000) and number of search agents/individuals (50) are the only two parameters that were adopted for all metaheuristics.

Table 1. Comparison of statistical results obtained by novel swarm-based metaheuristics

Algorithm	Worst value	Best value	Average value	Standard deviation
CSA	0.016523	0.012876	0.014114	0.0007643
GWO	0.012765	0.01267	0.012711	2.1078e-05
PSO	0.015369	0.012667	0.01328	0.00078137
WOA	0.01688	0.01267	0.013674	0.00097938
ALO	0.017549	0.012666	0.01339	0.0010299
BA	0.016062	0.012669	0.012963	0.00061963
FA	0.013594	0.012667	0.012768	0.00016988
ABC	0.018023	0.012918	0.013383	0.00080648
SOA	0.01314	0.0127	0.012767	5.9998e-05
CS	0.013741	0.012668	0.012849	0.00021589

Table 2 and Table 3 show the best solutions, i.e. best values for wire diameter, mean coil diameter and number of coils as well as values of the constraints obtained by GWO and WOA metaheuristics respectively. Fig. 4 represents the convergence curves for four swarm-based metaheuristics selected from the study. As it can be noticed, all the algorithms clearly express fast convergence towards the best fitness for this simple optimization task. With additional tuning of parameters and improvements in balance between exploitation and exploration phases, these modern metaheuristics could find more promising results for constrained engineering design problems.

Table 2. The best solution obtained by GWO algorithm for the tension/compression string design

Parameter	x_1 (d)	x_2 (D)	x_3 (P)	g_1
Value	0.051791	0.359144	11.1545	-0.00047155
Parameter	g_2	g_3	g_4	$f(\vec{x})$
Value	-7.1177e-05	-4.0558	-0.72604	0.012672

Table 3. The best solution obtained by WOA algorithm for the tension/compression string design

Parameter	x_1 (d)	x_2 (D)	x_3 (P)	g_1
Value	0.051791	0.359144	11.1545	-0.00047155
Parameter	g_2	g_3	g_4	$f(\vec{x})$
Value	-7.1177e-05	-4.0558	-0.72604	0.012672

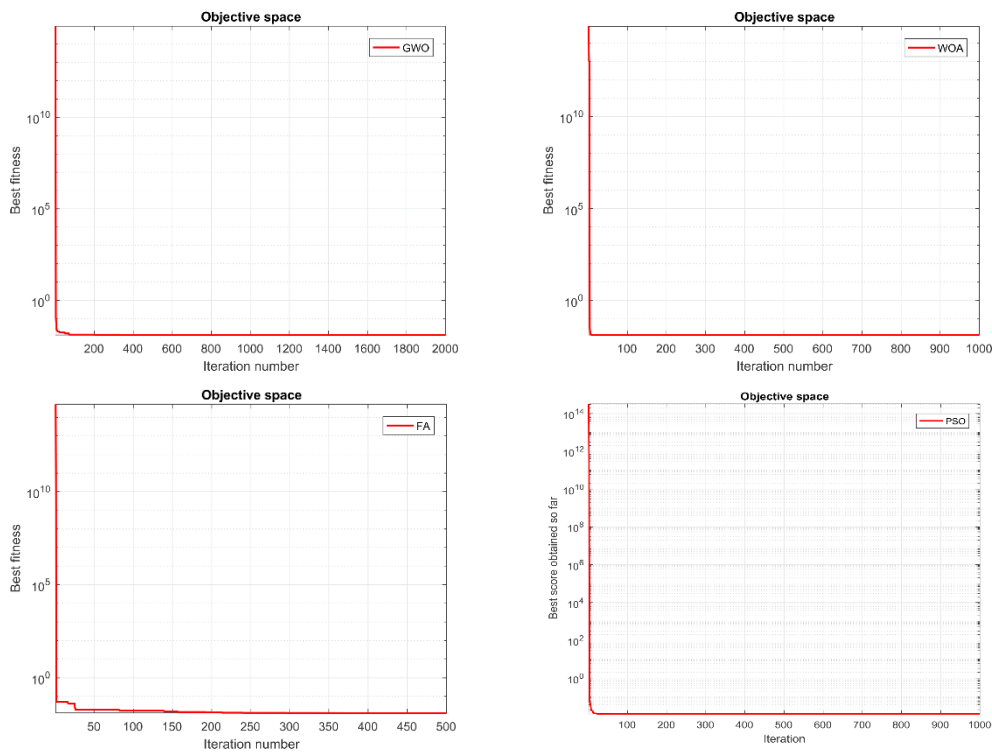

Fig 4. Convergence rates of GWO, WOA, FA and PSO algorithms respectively for finding the best possible fitness of tension/compression string design problem

CONCLUSION

Brief study represented in this paper considered the implementation of several modern swarm-based metaheuristic algorithms on constrained optimization problem well-known in the literature as the tension/compression string design problem. After short introduction to optimization in engineering design, the emphasis was put on metaheuristic algorithms, primarily on swarm-based group of metaheuristics. Their popularity has grown in years due to their simplicity, flexibility, problem independence and ease of implementation. Afterwards, tension/compression string problem was defined and mathematical formulations were given. Then, several swarm-based algorithms were applied and comparative results were obtained. Main statistical parameters were included in this comparative analysis and two of the best solutions were pointed out. Convergence curves represented the rate of

algorithms convergence toward best values. Short discussion was made to point out the significance of algorithm parameter tuning and improvements that should be considered in future studies in order to boost their performances and improve balance between exploration and exploitation phases.

ACKNOWLEDGEMENTS

This paper is part of a research on the project "Application of smart manufacturing methods in Industry 4.0", No.142-451-3173/2020, financed by the Provincial Secretariat for Higher Education and Scientific Research of the Autonomous Province of Vojvodina.

REFERENCES

- [1] Yang, X.-S.: Engineering Optimization: An Introduction with Metaheuristics Applications, Wiley, New Jersey, USA, 2010.
- [2] Belkourchia, Y., Azrar L., Zeriab, E.M.: A Hybrid Optimization Algorithm for Solving Constrained Engineering Design Problems, 5th International Conference on Optimization and Applications (ICOA), pp. 1-7, Kenitra, Morocco, 2019.
- [3] Mirjalili, S.: The Whale Optimization Algorithm, Advances in Engineering Software, Vol. 95, pp. 51-67, 2016.
- [4] Panigrahi, B.K., Shi, Y., Lim, M-H.: Handbook of Swarm Intelligence, Concepts, Principles and Applications, Springer, Berlin, Heidelberg, 2011.
- [5] Mirjalili, S.: Evolutionary Algorithms and Neural Networks, Theory and Applications, Springer, Cham, 2019.
- [6] Arora, J.: Introduction to Optimum Design, McGrawHill, 1989.
- [7] Belegundu, A., A Study of Mathematical Programming Methods for Structural Optimization, PhD thesis, Department of Civil Environmental Engineering, University of Iowa, Iowa, 1982.
- [8] Cagnina, L.C., Esquivel, S.C., Solving Engineering Optimization Problems with the Simple Constrained Particle Swarm Optimizer, Informatica (Slovenia), Vol. 32, pp. 319-326, 2008.
- [9] Coello, A.C.: Use of a self-adaptive penalty approach for engineering optimization problems, Computers in Industry, Vol. 41, No. 2, pp. 113-127, 2000.
- [10] Askarzadeh, A.: A novel metaheuristic method for solving constrained engineering optimization problems: Crow search algorithm, Computers and Structures, Vol. 169, pp. 1-12, 2016.
- [11] Mirjalili, S.: Grey Wolf Optimizer, Advances in Engineering Software, Vol. 69, pp. 46-61, 2014.
- [12] Kennedy, J., Eberhart, R., Particle swarm optimization, Proceedings of ICNN'95 - International Conference on Neural Networks, pp. 1942-1948, Perth, WA, Australia, 1995.
- [13] Mirjalili, S.: The Ant Lion Optimizer, Advances in Engineering Software, Vol. 83, pp. 80-98, 2015.
- [14] Yang, X.-S., Gandomi, A.H., Bat Algorithm: A Novel Approach for Global Engineering Optimization, Engineering Computations, Vol. 29, No. 5, pp. 464-483, 2012.
- [15] Yang, X.-S.: Firefly algorithms for multimodal optimization, International symposium on stochastic algorithms, pp. 169-178, Springer, Berlin, 2009.
- [16] Basturk, B., An artificial bee colony (ABC) algorithm for numeric function optimization, IEEE Swarm Intelligence Symposium, Indianapolis, IN, USA, 2006.
- [17] Dhiman, G., Kumar, V.: Seagull optimization algorithm: Theory and its applications for large-scale industrial engineering problems, Knowledge-Based Systems, Vol. 165, pp. 169-196, 2019.
- [18] Yang, X.-S. Deb, S.: Cuckoo Search via Lévy flights, 2009 World Congress on Nature & Biologically Inspired Computing (NaBIC), Coimbatore, pp. 210-214, 2009.

ANALYSIS OF CROSS-SECTION INFLUENCE ON EIGENFREQUENCIES OF THE CRANES WITH LOADING- UNLOADING TROLLEYS

Spasoje Trifković¹, Nebojša Radić¹, Miroslav Milutinović¹

¹University of East Sarajevo, Faculty of Mechanical Engineering, East Sarajevo,
Republic of Srpska, B&H

e-mail: spasoje.trifkovic@ues.rs.ba

Abstract: This paper presents the influence of cross-sectional size and plate metal thickness on eigenfrequencies of the cranes with loading-unloading trolleys on the slewing platform. Based on the multi-mass model of the crane differential equations of motion are obtained. Determination of eigenfrequencies of systems with more degrees of freedom represents an important phase in dynamic analysis and it is important from the aspect of supporting structures optimization.

Key words: cross section, dynamic model, eigenfrequency, crane, trolley

INTRODUCTION

The problem of constructions oscillation is especially important in mechanical engineering when analyzing the supporting structure of cranes. Research of the dynamic behavior of supporting structures is present in literature [1,2,3,4,5,6,7].

Oscillations in the metal structure, which is a system with an infinite number of degrees of freedom, will be discussed as oscillating of elastic system with a finite number of degrees of freedom. Because of that the mass of the construction is replaced by one or several reduced masses, whereby the system must have a minimum number of degrees of freedom. Replacing the existing masses of construction with the reduced masses comes from the assumption of dynamic equivalence of both systems [8].

DYNAMIC MODEL OF CRANE

Based on analysis of construction of cranes with loading-unloading trolley on slewing platform, a mathematical model of their metal construction as elastic dynamic system is made (Fig. 1) [8]. We will consider the metal construction of cranes as an eight-mass system with thirteen generalized coordinates. The given mathematical model is general for all types of cranes with loading-unloading trolley on slewing platform and it corresponds to the real working conditions of metal construction, because it includes all elements of the system elasticity and has a minimal number of degrees of freedom.

We will consider the case of simultaneous operation of all the basic mechanisms of crane: the movement of the bridge, trolley movement, lifting and rotation. System of equations of motion of the metal structure in general form is obtained, and it can be defined practically all possible cases of the crane operation.

MATHEMATICAL FORMULATION OF THE OSCILLATIONS

As shown in Fig. 1, there are two coordinate systems on the mathematical model. One of them is the $O_n X_n Y_n Z_n$ with the coordinate origin in O_n , and it is fixed. The other coordinate system is $OXYZ$ with the coordinate origin in O , and it moves together with the masses m_7 . Origin of the coordinate system $OXYZ$ is chosen as the middle of the left beam of the bridge in the position of equilibrium of elastic system. The axis X is directed horizontally along the span of the bridge to the side of the right beam of the bridge. The axis Z is directed horizontally along the beam of the bridge, and the axis Y is directed vertically on the underside of the crane.

The reduced masses are:

- m_1 - mass of the left beam of the bridge (without beam ends), presented in the middle of the

bridge;

- m_2 - mass of the right beam of the bridge (without beam ends), presented in the middle of the bridge;
- m_3 - part of the mass of the gripping device, related to the left half of the bridge;
- m_4 - part of the mass of the gripping device, related to the right half of the bridge;
- m_5 - part of the mass of the gripping device, which is reduced to the upper end of the gripping devices;
- m_6 - mass of the payload and part of the mass of horizontal overhanging beam;
- m_7 - beam ends mass and part of the reduced mass of the bridge.

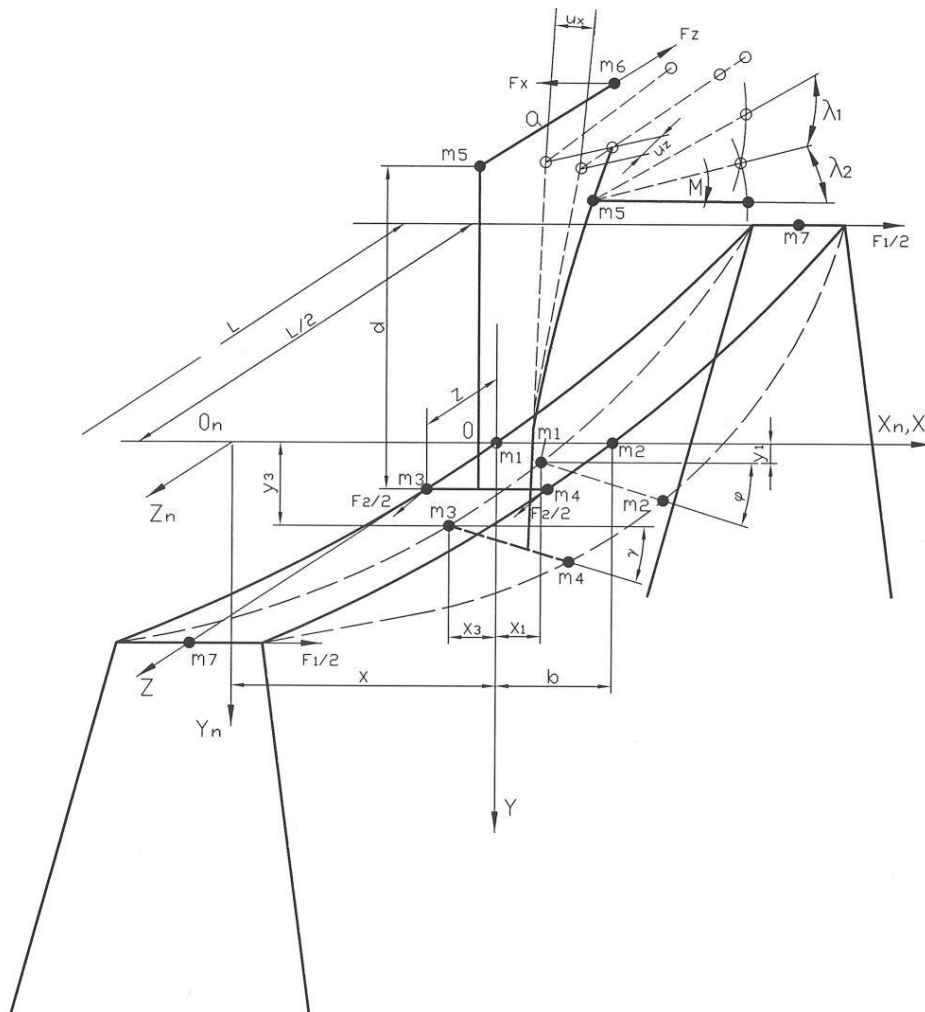

Fig. 1. The multi-mass model of a crane with loading-unloading trolley on slewing platform [8].

Generalized coordinates are:

- x - horizontal movement of point O along axis X from fixed point O_n ;
- x_1 - horizontal movement of mass m_1 along axis X from point O ;
- y_1 - vertical movement of mass m_1 along axis Y from point O ;
- φ - angle between the reduced masses m_1 and m_2 ;
- x_3 - horizontal movement of mass m_3 along axis X from point O ;
- y_3 - vertical movement of mass m_3 along axis Y from point O ;
- z - horizontal movement of mass m_3 along axis Z from point O ;
- γ - rotation angle of trolley;
- d - vertical movement of masses m_5 and m_6 ;
- u_x - movement of the upper end of the vertical overhanging beam along axis x ;
- u_z - movement of the upper end of the vertical overhanging beam along axis Z ;

- λ_2 - rotation angle of the horizontal overhanging beam in the swing;
- λ_1 - rotation angle of the horizontal overhanging beam around vertical overhanging beam.

The generalized non-conservative forces:

- F_1 - force of the bridge movement mechanism;
- F_2 - force of the trolley movement mechanism;
- M - moment on the horizontal overhanging beam;
- F_x and F_z - force components at the end of the horizontal overhanging beam.

For deriving the differential equations of motion, the second-order Lagrange equations of the following form were used. Basis for the mathematical model shown in Fig. 1.:

$$\frac{d}{dt} \left(\frac{\partial E_k}{\partial \dot{q}} \right) - \frac{\partial E_k}{\partial q} + \frac{\partial E_p}{\partial q} = Q_q \quad (1)$$

Where

$q = f(x, x_1, y, \phi, x_3, y_3, z, \gamma, d, u_x, u_z, \lambda_2, \lambda_1)$ - independent generalised coordinates;

E_k and E_p - kinetic and potential energy of the elastic system;

$$\begin{aligned} E_k = & \frac{1}{2} a_{00} \dot{x}^2 + a_{01} \dot{x} \dot{x}_1 + a_{04} \dot{x} \dot{x}_3 + a_{07} \dot{x} \dot{\gamma} + a_{09} \dot{x} \dot{u}_x + a_{012} \dot{x} \dot{\lambda}_1 + \frac{1}{2} a_{11} \dot{x}_1^2 + \frac{1}{2} a_{22} \dot{y}_1^2 + a_{23} \dot{y}_1 \dot{\phi} + \frac{1}{2} a_{33} \dot{\phi}^2 + \\ & + \frac{1}{2} a_{44} \dot{x}_3^2 + a_{47} \dot{x}_3 \dot{\gamma} + a_{49} \dot{x}_3 \dot{u}_x + a_{412} \dot{x}_3 \dot{\lambda}_1 + \frac{1}{2} a_{55} \dot{y}_3^2 + a_{57} \dot{y}_3 \dot{\gamma} + a_{58} \dot{y}_3 \dot{d} + a_{511} \dot{y}_3 \dot{\lambda}_2 + \frac{1}{2} a_{66} \dot{z}^2 + a_{610} \dot{z} \dot{u}_z + \\ & a_{612} \dot{z} \dot{\gamma} + \frac{1}{2} a_{77} \dot{\gamma}^2 + a_{78} \dot{\gamma} \dot{d} + a_{79} \dot{\gamma} \dot{u}_z + a_{711} \dot{\gamma} \dot{\lambda}_2 + a_{712} \dot{\gamma} \dot{\lambda}_1 + \frac{1}{2} a_{88} \dot{d}^2 + a_{811} \dot{d} \dot{\lambda}_2 + \frac{1}{2} a_{99} \dot{u}_x^2 + a_{912} \dot{u}_x \dot{\lambda}_1 + \\ & + \frac{1}{2} a_{1010} \dot{u}_z^2 + a_{1012} \dot{u}_z \dot{\lambda}_1 + \frac{1}{2} a_{1111} \dot{\lambda}_2^2 + \frac{1}{2} a_{1212} \dot{\lambda}_1^2. \end{aligned}$$

$$\begin{aligned} E_p = & \frac{1}{2} c_{11} x_1^2 + c_{14} x_1 x_3 + \frac{1}{2} c_{22} y_1^2 + c_{23} y_1 \phi + c_{25} y_1 y_3 + c_{27} y_1 \phi + \frac{1}{2} c_{33} \phi^2 + c_{35} \phi y_3 + c_{37} \phi \gamma + \\ & + \frac{1}{2} c_{44} x_3^2 + \frac{1}{2} c_{55} y_3^2 + c_{57} y_3 \gamma + \frac{1}{2} c_{77} \gamma^2 + \frac{1}{2} c_{88} d^2 + \frac{1}{2} c_{99} u_x^2 + \frac{1}{2} c_{1010} u_z^2 + \frac{1}{2} c_{1212} \lambda_1^2. \end{aligned}$$

Generalized forces are obtained using virtual displacements:

- 1) $Q_x = F_1 + F_x + m_6 a \cos \lambda_1 \ddot{\lambda}_1$;
- 2) $Q_{x1} = 0$;
- 3) $Q_{y1} = 0$;
- 4) $Q_\phi = 0$;
- 5) $Q_{x3} = F_x + m_6 a \cos \lambda_1 \ddot{\lambda}_1$;
- 6) $Q_{y3} = -(m_5 + m_6) \ddot{d}$;
- 7) $Q_z = F_2 + F_z + m_6 a \sin \lambda_1 \ddot{\lambda}_1$;
- 8) $Q_\gamma = -F_x d - \frac{1}{2} (m_5 + m_6) b \ddot{d} - m_6 a d \cos \lambda_1 \ddot{\lambda}_1$;
- 9) $Q_d = -(m_5 + m_6) \ddot{d}$;
- 10) $Q_{u_x} = -F_x - m_6 a \cos \lambda_1 \ddot{\lambda}_1$;

- 11) $Q_{uz} = F_z + m_6 a \sin \lambda_1 \ddot{\lambda}_1$;
- 12) $Q_{\lambda 2} = M + m_6 a \ddot{d}$;
- 13) $Q_{\lambda 1} = -F_x a - (I_5 + m_6 a^2) \ddot{\lambda}_1$.

Where:

- a_{ik} - mass coefficients;
- c_{ik} - stiffness coefficients;
- i - number of equations;
- k - number of independent variable

The multi-mass model of a crane with loading-unloading trolley on slewing platform is shown in figure 2. The assumption is that the trolley is loaded and it is in the middle of the bridge, transverse to the axis of the bridge. In that case we have:

$$x=0; \quad \ddot{x}=0; \quad d=const; \quad \ddot{d}=0; \quad x_1=0; \quad \ddot{x}_1=0; \quad u_x=0; \quad \ddot{u}_x=0; \quad x_3=0; \quad \ddot{x}_3=0;$$

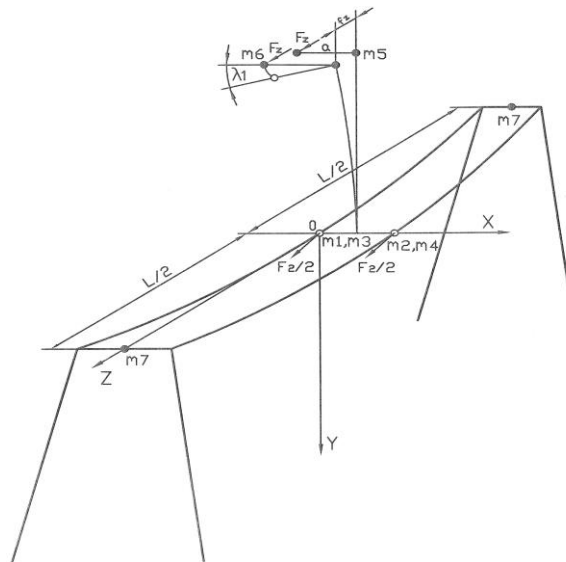

Fig. 2. The multi-mass model of a crane in case of loaded trolley movement
Replacing concrete data in the (1) gives system of equations (2):

$$\begin{aligned} a_{66} \ddot{z} + a_{6,10} \ddot{u}_z + a_{6,12} \ddot{\lambda}_1 &= F_2 + F_z \\ a_{10,6} \ddot{z} + a_{10,10} \ddot{u}_z + a_{10,12} \ddot{\lambda}_1 + c_{10,10} u_z &= F_z \\ a_{12,6} \ddot{z} + a_{12,10} \ddot{u}_z + a_{12,12} \ddot{\lambda}_1 + c_{12,12} \lambda_1 &= -F_z a \end{aligned} \quad (2)$$

Elimination of members which contains term \ddot{z} gives following system of equations (3):

$$\begin{aligned} a_{1f} \ddot{u}_z + a_{1\alpha} \ddot{\lambda}_1 + c_f u_z &= a_{1Q} \\ a_{2f} \ddot{u}_z + a_{2\alpha} \ddot{\lambda}_1 + c_\alpha \lambda_1 &= a_{2Q} \end{aligned} \quad (3)$$

Where

$$a_{1\alpha} = a_{66} a_{10,12} - a_{10,12} - a_{10,6} a_{6,10};$$

$$\begin{aligned}c_f &= a_{66}c_{10,10}; \\a_{1Q} &= -a_{10,6}F_2 + (a_{66} - a_{10,6})F_z; \\a_{2f} &= a_{66}a_{12,10} - a_{12,6}a_{6,10}; \\a_{2\alpha} &= a_{66}a_{12,12} - a_{12,6}a_{6,12}; \\c_f &= a_{66}c_{12,12}; \\a_{2Q} &= -a_{12,6}F_2 - (a_{12,6} - a_{66}a)F_z.\end{aligned}$$

Non-conservative forces F_2 and F_z acting on the system.

For $F_2 = N_2 = const$; $F_z = const$

The system of equations (3) takes the form:

$$\begin{aligned}a_{1f}\ddot{u}_z + a_{1\alpha}\ddot{\lambda}_1 + c_f u_z &= -a_{10,6}N_2 + (a_{66} - a_{10,6})F_z; \\a_{2f}\ddot{u}_z + a_{2\alpha}\ddot{\lambda}_1 + c_\alpha \lambda_1 &= -a_{12,6}N_2 - (a_{12,6} - a_{66}a)F_z.\end{aligned}$$

The general solution of this system of equations is:

$$\begin{aligned}u_z &= A_{10}^{(10)} \sin(\omega_{10}t + \delta_{10}) + A_{10}^{(12)} \sin(\omega_{12}t + \delta_{12}) + D'_{10} \\ \lambda_1 &= A_{12}^{(10)} \sin(\omega_{10}t + \delta_{10}) + A_{12}^{(12)} \sin(\omega_{12}t + \delta_{12}) + D'_{12}\end{aligned}$$

Where

$$\begin{aligned}D'_{10} &= \frac{-a_{10,6}N_2 + (a_{66} - a_{10,6})F_z}{c_f}; \\ D'_{12} &= \frac{a_{12,6}N_2 - (a_{12,6} - a_{66}a)F_z}{c_\alpha}.\end{aligned}$$

Dynamic loads:

$$\begin{aligned}P_{vz} &= u_z c_v; \\ M_{zu} &= \lambda_1 c_{zu},\end{aligned}$$

Where

P_{vz} - load on the upper end of the gripping devices along axis Z;
 c_v - flexural stiffness;
 M_{zu} - moment on the upper end of the gripping devices;
 c_{zu} - torsional stiffness.

We will consider the case of the approximate solution of equations of motion during functioning of trolley mechanism, under following assumption $F_2 = N_2 = const$; $F_z = const$.

Approximate determination of dynamic loads which acting on the horizontal plane on the upper end of the gripping devices along axis Z. We assume that the trolley is absolutely rigid in torsion. Differential equation of motion is:

$$a_{1f}\ddot{u}_z + c_f u_z = -a_{10,6}N_2 + (a_{66} - a_{10,6})F_z,$$

and angular frequency of oscillation

$$\omega_f = \sqrt{\frac{c_f}{a_{1f}}} \quad (4)$$

Solution of differential equation:

$$u_z = A_f \sin(\omega_f t + \delta_f') + A_{10}^{(12)} \sin + D'_{10}$$

Horizontal dynamic load which acting on the upper end of gripping devices:

$$P_{vz} = u_z c_v.$$

ANALYSIS OF THE RATIO BETWEEN THE THICKNESS OF VERTICAL AND HORIZONTAL PLATES ON EIGENFREQUENCIES

An analysis of the influence of the plate thicknesses ratio of the horizontal and vertical plates of the main longitudinal beam of the crane on the eigenfrequencies are obtained, based on equation (4). Eigenfrequency graphs for different parameters were made in the Matlab package software.

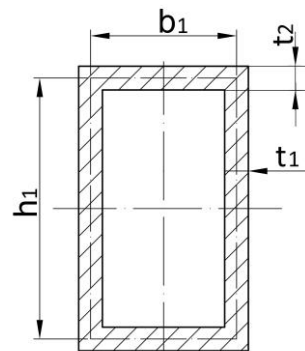

Fig. 3. Cross-section of the main box girder

In these studies, the case of box-type girders with aligned edges of horizontal and vertical plates was analyzed. The beam lengths are $l_1=15\text{m}$, $l_2=20\text{m}$ and $l_3=25\text{m}$, and the plate thicknesses are $t_1=10\text{mm}$; 12mm and 14mm and $t_2=12\text{mm}$; 15mm и 18mm . The width of the cross-section b_1 is from 400mm to 600mm and the height h_1 is 800mm ; 1000mm and 1200mm . For different heights of box girders, and the same thickness of vertical and horizontal plates, using the Matlab software package, eigenfrequencies were obtained for $t_1=10\text{mm}$, $t_2=12\text{mm}$ and different heights $h_1=800\text{mm}$ (Fig. 4.), $h_1=1000\text{mm}$ (Fig. 5.) and $h_1=1200\text{mm}$ (Fig. 6.).

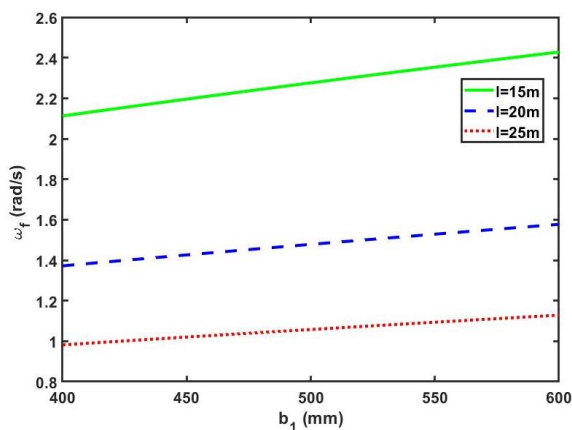

Fig. 4. Eigenfrequencies for $t_1=10\text{mm}$, $t_2=12\text{mm}$ and $h_1=800\text{mm}$

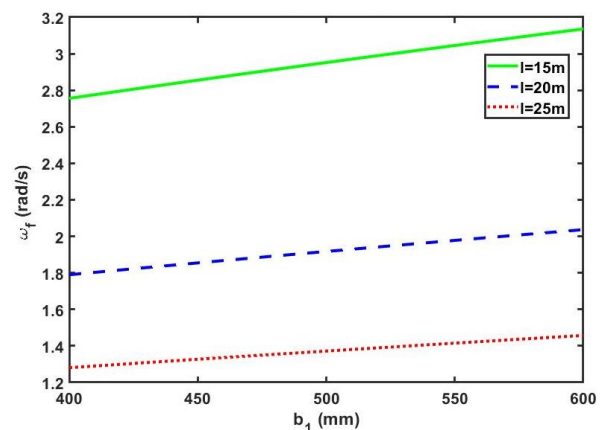

Fig. 5. Eigenfrequencies for $t_1=10\text{mm}$, $t_2=12\text{mm}$ and $h_1=1000\text{mm}$

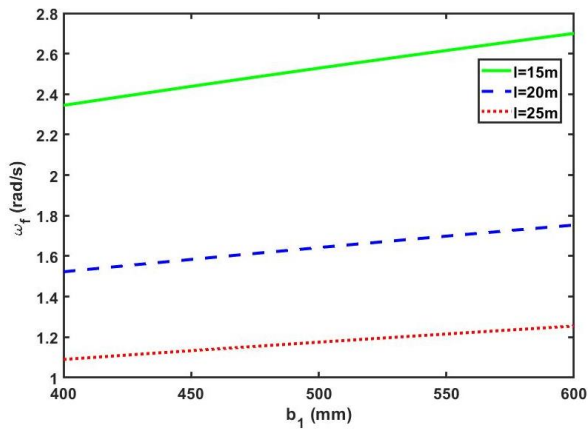

Fig. 6. Eigenfrequencies for $t_1=10\text{mm}$, $t_2=12\text{mm}$ and $h_1=1200\text{mm}$

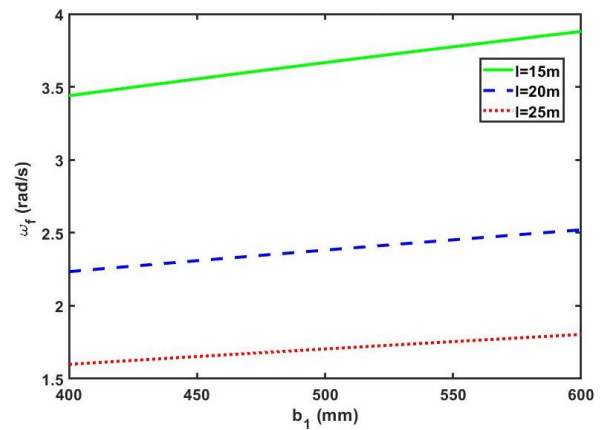

Fig. 7. Eigenfrequencies for $t_1=12\text{mm}$, $t_2=15\text{mm}$ and $h_1=800\text{mm}$

Figures 7, 8 and 9 show the values of eigenfrequencies for $t_1=12\text{mm}$ and $t_2=15\text{mm}$ and the same values of b_1 , l and h_1 as in the previous case.

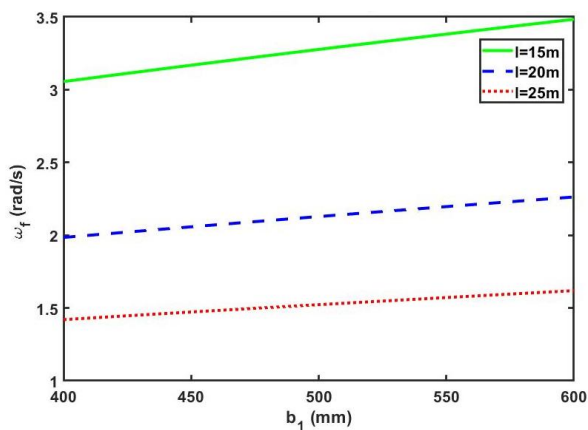

Fig. 8. Eigenfrequencies for $t_1=12\text{mm}$, $t_2=15\text{mm}$ and $h_1=1000\text{mm}$

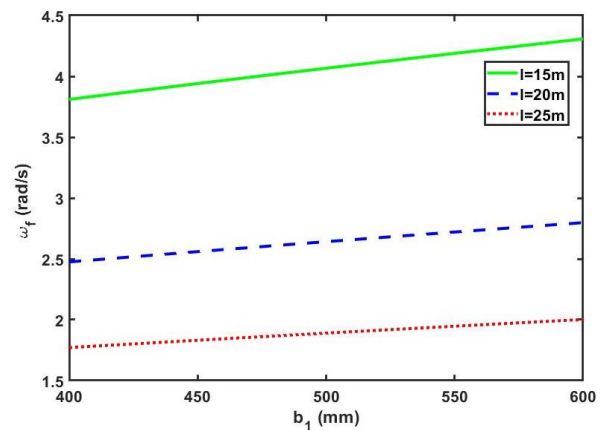

Fig. 9. Eigenfrequencies for $t_1=12\text{mm}$, $t_2=15\text{mm}$ and $h_1=1200\text{mm}$

Figures 10, 11 and 12 show the values of natural frequencies for $t_1=14\text{mm}$ and $t_2=18\text{mm}$ and the same other parameters as in the previous cases.

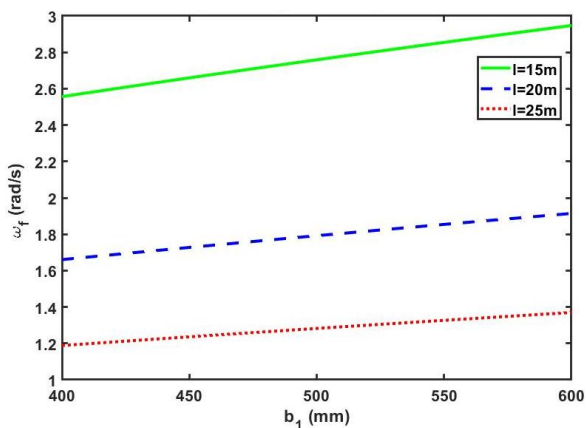

Fig. 10. Eigenfrequencies for $t_1=14\text{mm}$, $t_2=18\text{mm}$ and $h_1=800\text{mm}$

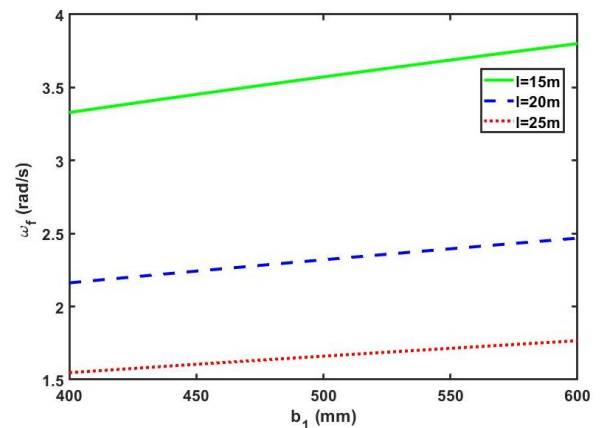

Fig. 11. Eigenfrequencies for $t_1=14\text{mm}$, $t_2=18\text{mm}$ and $h_1=1000\text{mm}$

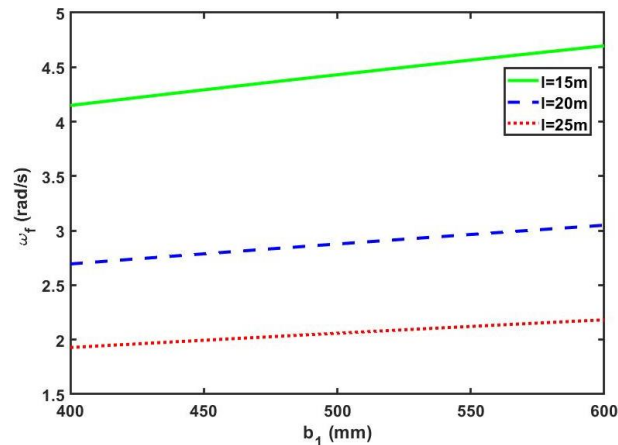

Fig. 10. Eigenfrequencies for $t_1=14mm$, $t_2=18mm$ and $h_1=1200mm$

CONCLUSION

From Figures 4, 5 and 6 it can be seen that with increasing magnitude b_1 the eigenfrequency increases linearly with increasing h_1 for all three lengths. The largest increase in eigenfrequency is for $l=15m$ and $h_1=1000mm$ and it is 13.80%, and the smallest one for $l=25m$ and $h_1=1200mm$ and it is 12.88%. For values $t_1=12mm$, $t_2=15mm$ (Figures 7,8 and 9) the largest increase in eigenfrequency is for values $l=15m$ and $h_1=800mm$ and it is 15.15% and the smallest one for $l=25m$ and $h_1=1200mm$ and it is 13.03%. The highest percentage of eigenfrequency increase for values $t_1=14mm$, $t_2=18mm$ is for $l=15m$ and $h_1=800mm$ and it is 15.29% and the lowest is for $l=25m$ and $h_1=1200mm$ and it is 13.19% (Figure 10,11 and 12).

REFERENCES

- [1] Karnovsky, I. A., Lebed, O. (2010). Advanced methods of structural analysis, Springer New York, London.
- [2] Clough, R. W., Penzien J., Dynamics of structures, McGraw-Hill, New York, 1993.
- [3] Chorpa, A. K., Dynamics structures -Theory and Application to Earthquake Engineering, 3rd edition, Prentice Hall, New Jersey, 2006.
- [4] Brčić, V., Dynamics of Constructions, Civil book, Belgrade, 1978. (in Serbian)
- [5] Ostrić, D., Dynamics of Bridge Cranes, Faculty of Mechanical Engineering, Belgrade, 1998. (in Serbian)
- [6] Georgijević, M., Dynamics of Crane - Experimental and Model Analysis, Belgrade, 1996. (in Serbian)
- [7] Jerman B., Hribar.A.: Dynamics of the mathematical pendulum suspended from a moving mass, Tehnički vjesnik – Technical Gazette, ovol. 20, no.1, p.59-64, 2013.
- [8] Trifković, S., Gašić, M., Radić, N., Milutinović, M., Dynamic Analysis of the Crane with Loading- unloading Trolley on the Slewing Platform, IMK-14 – Research & Development in Heavy Machinery 21(2015)1, EN1-6 UDC 621 ISSN 0354-6829.

NUMERICAL INVESTIGATION OF THERMAL AND MECHANICAL BEHAVIOR OF WAFER MOLD

Omer Sinan Sahin¹, Muharrem Hilmi Aksoy¹, Abdullah Sadik Tazegul²

¹Konya Technical University, Faculty of Engineering and Natural Sciences, Department of Mechanical Engineering, 42250, Konya, Turkey

²Tüfekçioğulları Mak. Gıda İml. San. ve Tic. Ltd. Şti., Karaman, Turkey

e-mail: : ossinan@ktun.edu.tr, mhaksoy@ktun.edu.tr s.tazegul@nefamak.com

Abstract: In this study, the temperature distributions on the cooking surfaces and the mechanical stresses caused by the pressure arising during cooking proses of the wafer baking molds made of different materials to be used in wafer baking ovens were numerically investigated. Four different materials, GGG-40, GGG-45, GG-25, GJV-350, were examined. Since the structural integrity must be demonstrated in all loading situations encountered by the molds, simulations have been done using the finite element method. It is seen that metal types have little effect on the heating time of the molds. In the thermal expansion analysis, it was seen that the material made of structural steel next to the molds was incompatible with the main material.

Key words: Thermal distribution, mechanical behavior, heat transfer.

INTRODUCTION

Wafer production machines have an important place in the food machinery industry. One of the most important machine of the wafer production line is the wafer sheet baking oven. The wafer dough is baked by pouring it between the heated molds in the oven. The wafer baking molds move on rails in a chain driven manner in the oven and complete the cooking process after one full turn. After the liquid dough is poured into the mold, the bottom part is cooked first (on the upper cooker) and the half turn is completed. Then, with the mechanism, the molds turn to the lower part and the upper part is baked. Thus, the mold completes one full turn. Then the molds are opened and the baked wafer sheet comes out of the oven automatically. These products are produced in different sizes between 280 and 1000 mm. The thickness of the wafer sheet is can be between 2.5 mm-4.6 mm depending on the customer request. A wafer oven can contain up to 200 baking molds.

Liquid wafer dough is poured in a certain amount (150-220 g) between the wafer baking molds and baked in the oven within 2.2-3 minutes [1-3]. Natural gas or LPG is used to provide the necessary heat requirement. The internal temperature of the wafer oven is between 200-250 ° C [1]. The furnace is heated for 45-90 minutes when it is first started, and then the furnace is heated, with constant continuous combustion by small flame lengths.

In Figure 1, the drawing of the wafer leaf cooking mold is given. During baking, the surface temperatures of the molds should be between 120-190 ° C [1, 4-5]. Since wafer dough has a potential to ferment above room temperature (26 °C), the temperature of the dough must be between 8-18°C [6-7].

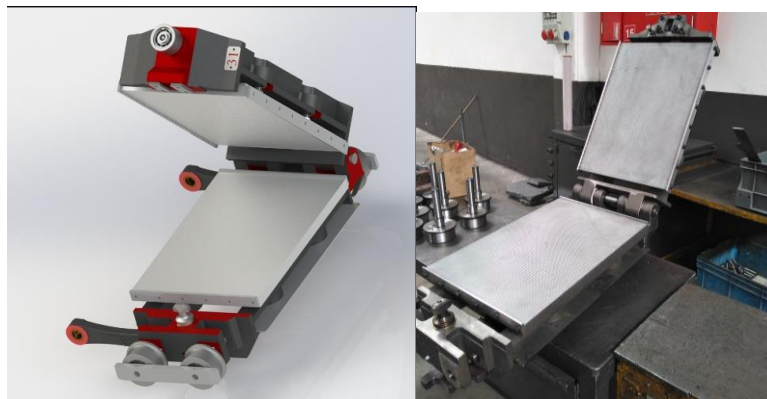

Fig. 1. Drawing and photograph of the wafer mold

Tiefenbacher [1] stated in his study that the wafer mold caused a 7-8 °C decrease in the temperature of the wafer dough poured into the baking plate, and after about 80 seconds the temperature of dough and mold came to balance.

There is 52-58% water in the wafer dough. While the wafer dough is cooked between the molds, the water in the dough passes into the vapor phase and causes a pressure of 1-1.3 bar to the wafer mold [8].

Wafer baking molds are made by casting (Spherical Graphite or Lamel Graphite Casting) manufacturing method. The reason for using cast material is that the casting can transmit heat homogeneously to the whole wafer sheet with its late cooling feature. In wafer production, it is necessary to provide a homogeneous heat distribution throughout the wafer sheet in order for the wafer sheet to be cooked in the desired thickness, weight and homogeneous manner.

In this study, the effects of temperature distribution and thermal deformations of four different materials (EN-GJS-400, EN-GJS-450, EN-GJL-25, EN-GJV-350) used in wafer baking mold were analyzed numerically. Proper boundary conditions are applied according to the literature and measurements.

MATERIAL AND METHODS

Since the continuity of structural integrity must be demonstrated in all loading situations encountered by the molds during the study, simulations were made using the finite element method.

The transient heat transfer in a homogeneous, isotropic body, involving the conduction and convection phenomena can be expressed by the well-known diffusion equation below, where t represents time, $T(x,y,z,t)$ represents temperature distribution. The $\alpha(m^2/s)=k/(\rho \cdot c)$ represents thermal diffusivity, where k , thermal conductivity; ρ , density; and c , specific heat capacity [9-10].

$$\frac{\partial^2 T}{\partial x^2} + \frac{\partial^2 T}{\partial y^2} + \frac{\partial^2 T}{\partial z^2} + \frac{\dot{q}}{k} = \frac{1}{\alpha} \frac{\partial T}{\partial t} \quad (1)$$

If the change in temperature distribution in a structure is known, the deformation that occurs depending on the temperature can be calculated. This initial shape change due to temperature variation can be calculated by ϵ_0 and expressed as follows where α_1 is the shape change due to temperature:

$$\epsilon_0 = \alpha_1 \Delta T \quad (2)$$

Where, α represents the thermal expansion and ΔT represents the nodal temperatures. Hence the following equation is obtained

$$\sigma = E(\epsilon - \epsilon_0) \quad (3)$$

After solving the finite elements equations the resulting stresses can be expressed as follows

$$\sigma = E([B]q - \alpha_1 \Delta T) \quad (4)$$

Where displacement, stress and strain components of nodes are as follows respectively.

$$\{u\} = [u, v, w]^T \quad (5)$$

$$\{\sigma\} = [\sigma_x, \sigma_y, \sigma_z, \tau_{yz}, \tau_{xz}, \tau_{xy}]^T \quad (6)$$

$$\{\epsilon\} = [\epsilon_x, \epsilon_y, \epsilon_z, \gamma_{yz}, \gamma_{xz}, \gamma_{xy}]^T \quad (7)$$

For isotropic media the stress vector is expressed as $\sigma=[D]\{\varepsilon\}$ where $[D]$ is elasticity matrix of 6x6 dimensions. After solving the above mentioned equations, the stress components can be used to evaluate equivalent stress at any point by using von-Mises equation as follows.

$$\sigma_{es} = \sigma_{vm} = \sqrt{\frac{1}{2}[(\sigma_y - \sigma_z)^2 + (\sigma_x - \sigma_z)^2 + (\sigma_x - \sigma_y)^2 + 6(\tau_{yz}^2 + \tau_{xz}^2 + \tau_{xy}^2)]} \quad (8)$$

The solid model of the construction was created, and the transient thermal and static stress analysis were performed on the model using the finite element method with the loading conditions taken from the literature and measured experimentally.

In the transient thermal analysis, the environment inside the furnace was defined as constant 200 °C and it was accepted that heat transfer occurs from this environment to the mold. In the mold, heat transfer by conduction is defined. In the analysis, film coefficients, heat conduction coefficients, specific heat and density values of each material are defined. The temperature of the wafer dough poured into the heated mold is defined as 10 °C. In the static loading analysis, as well as the mass of the mold itself, the internal pressure of 1.3 bar in the area where the dough is located during baking is defined.

Due to the ductile character of the materials used in the construction, the nodal forces obtained as a result of the finite element analysis were transformed into equivalent stresses with the help of the Von Mises equivalence criteria and used in the evaluation of the safety situation.

The properties of the materials used in mold construction are defined as indicated in Table 1. Components other than the specified materials (bolts, etc.) are accepted as structural steel.

Table 1. Material Properties

Property	Unit	GGG-40	GGG-45	GG-25	GJV-350
Heat conduction coefficient	W/(m.K)	37	36,2	46,5	41
Fatigue limit	MPa	210	210	115	165
Elasticity module	GPa	169	169	118	135
Tensile Strength	MPa	400	450	250	350
Yield Strength	MPa	250	310	-	245
Thermal Expansion coefficient	10 ⁻⁶ (1/°C)	13,5	12,5	12	12
Specific heat	J/(kg.K)	494	494	494	475
Poisson's ratio	-	0,27	0,28	0,26	0,26
Density	kg/m ³	7100	7250	7200	7100

In thermal analysis, the presence of wafer dough in the system was simulated by using the virtual topology and element birth / death approach using multiple loading steps. The entire construction is modeled as a solid and the Bonded Contact algorithm has been defined and used at the connection points of different components in the construction. All welding zones in the structure are accepted as having excellent welding quality. The solution was simplified by excluding all components that do not bear a structural load in the analysis. Bolt-like fasteners are modeled using beam elements in order not to cause stress singularity.

RESULTS AND DISCUSSION

In Figure 2, the temperature distributions obtained at the end of 3732 seconds with transient thermal analysis at 200 °C in the oven ambient temperature are given for different materials. It is observed that the area where the dough is poured in the mold heated in the oven warms up relatively late compared to other regions. Within the specified time, it was observed that molds made of different materials reached approximately the same temperatures, and the maximum temperature above the mold made of only GGG40 material was 2°C lower. In Figure 3, temperature distributions of the cooking zones where

the dough touched are presented. As seen in the figure, it is characteristically 5-10 °C lower than the edges of the middle parts of the mold. In addition, when the behavior of molds made of different materials is examined, it is seen that the average temperature is around 5 °C higher in the mold made of GJV350 material.

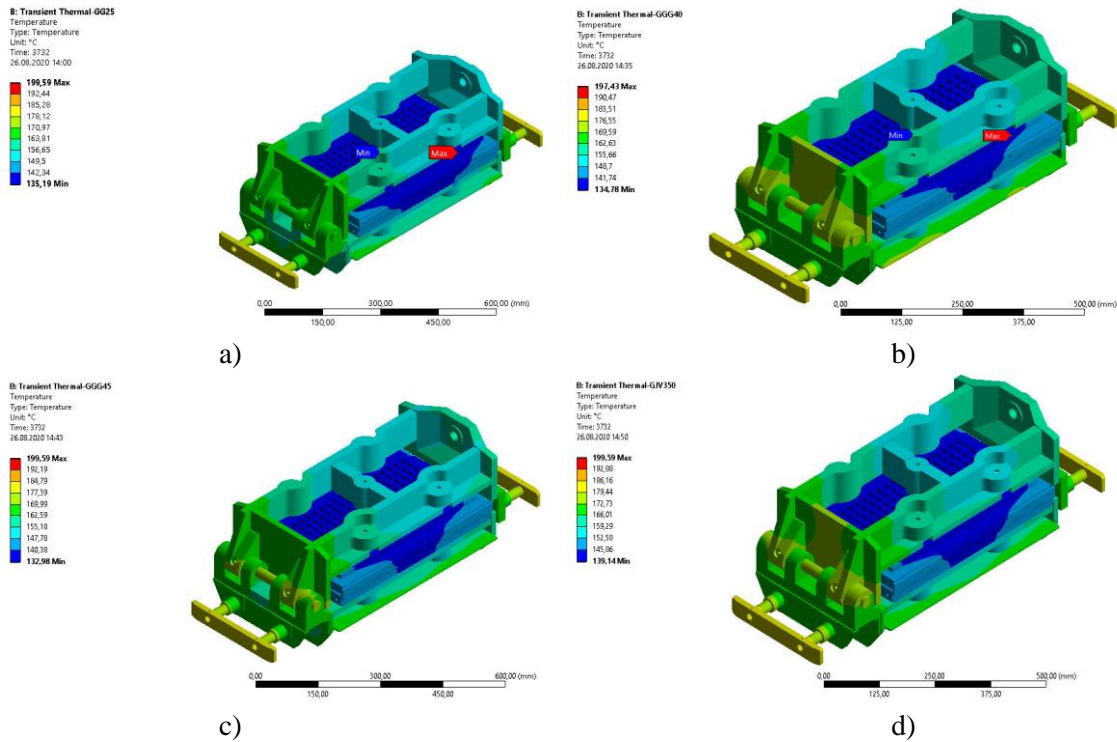

Fig. 2. Temperature distribution of the wafer molds made of different materials after 3732 s
 a) GG25 b) GGG40 c) GGG45 d) GJV350

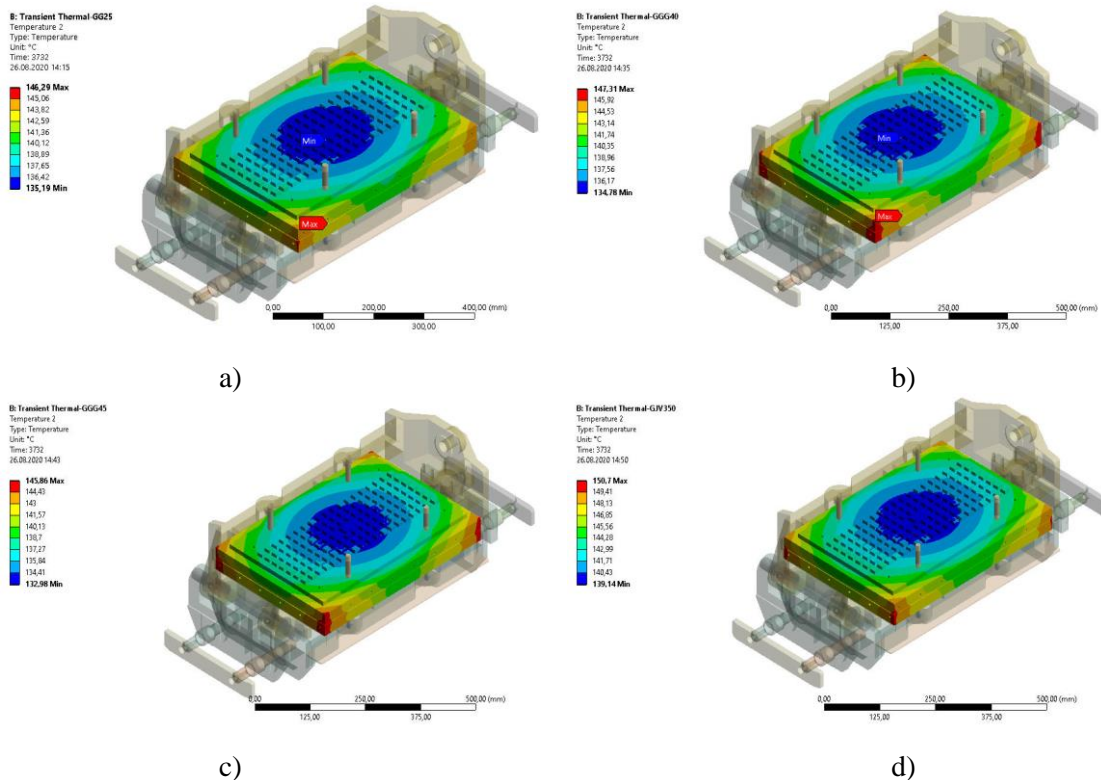

Fig. 3. Temperature distribution of the wafer molds made of different materials after 3732 s
 a) GG25 b) GGG40 c) GGG45 d) GJV350

Temperature changes during the heating of the molds are given in Figure 4. When the graphics are examined, it is seen that the fastest heating in terms of average temperature is in the mold made of GJV350 material and the slowest heating is in the mold made of GGG45 material. Although the specified differences are not too great, it was evaluated that the time required for the average mold temperature to reach 140 °C caused a difference of 5 minutes between GJV350 and GGG45 materials. Under real cooking conditions, the molds are heated for a while (approximately 45-60 minutes), then the dough is poured and the baking process is done. Therefore, in the analysis, the dough was first defined as death and was modeled to provide real conditions by activating the molds after warming up. When Figure 5 is examined, it is seen that pouring the dough into the mold suddenly decreases the average temperature value for a short time. It is seen that this decrease is around 10 °C locally and causes a decrease of 2 °C in the mold on average. It was observed that this decrease was compensated in approximately 90 seconds in the mold made of GJV350 material and in approximately 120 seconds in the mold made of GGG45 material, and it was observed that the dough and mold reached the same temperature.

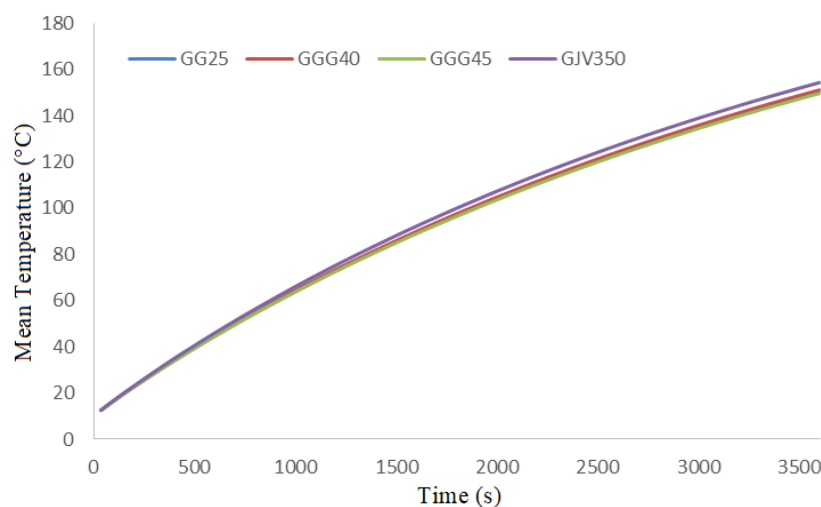

Fig. 4. Change of average temperature according to time during pre-heating process

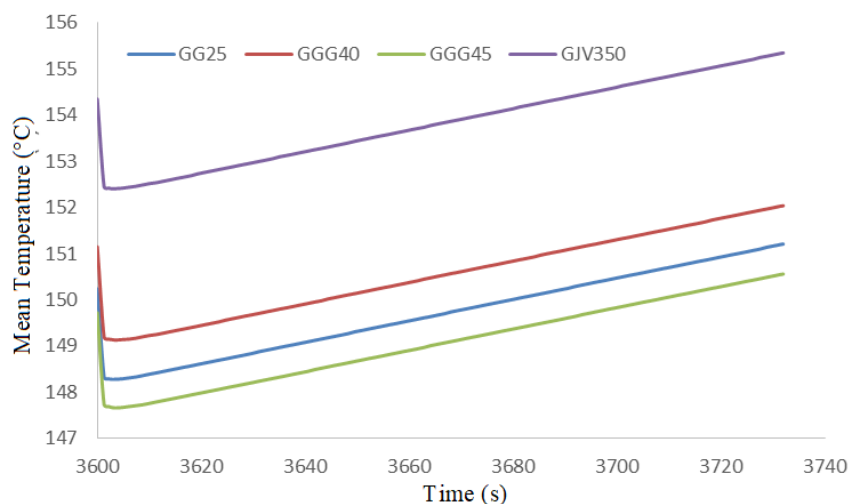

Fig. 5. Temperature change after pouring wafer dough into the mold

Figure 6 shows the total deformation values caused by the weight of the molds and thermal expansion. Since the densities of different materials are close to each other, approximately the same deformation values have been achieved in all materials. The specified deformation values vary between 1.2 mm-1.35 mm. The specified values are at a level that will not disturb the structural integrity of the mold or cause geometric nonlinearity.

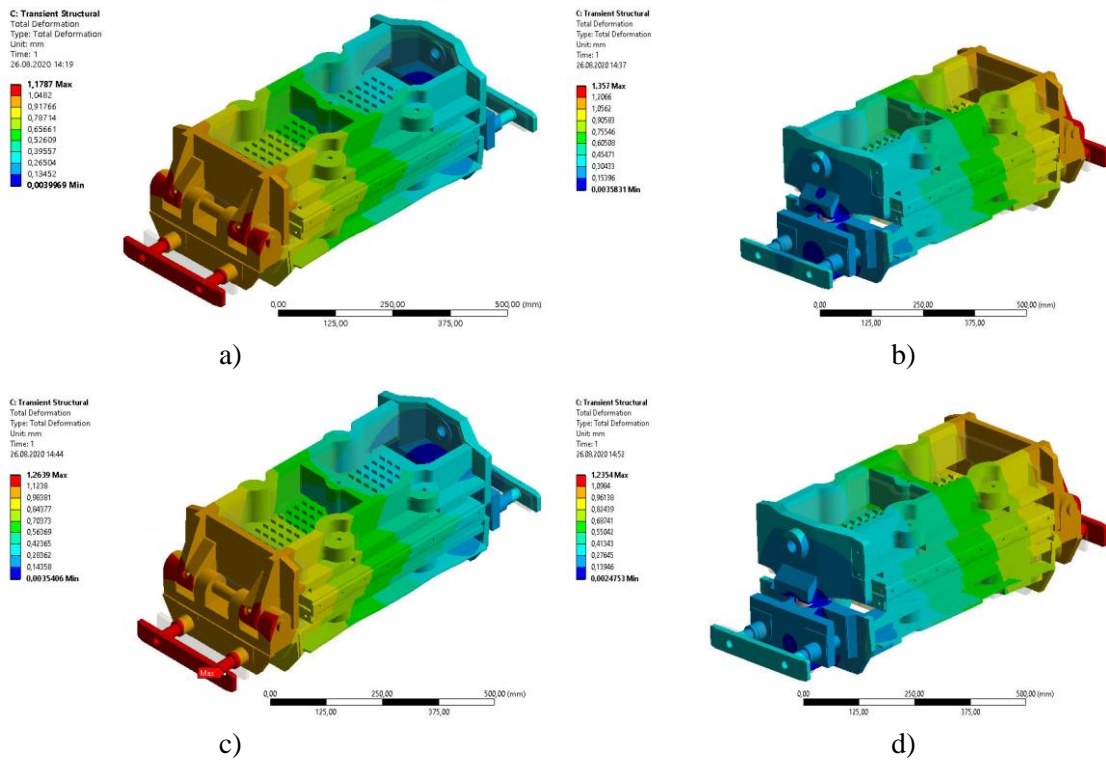

Fig. 6. Total deformation a) GG25 b) GGG40 c) GGG45 d) GJV350

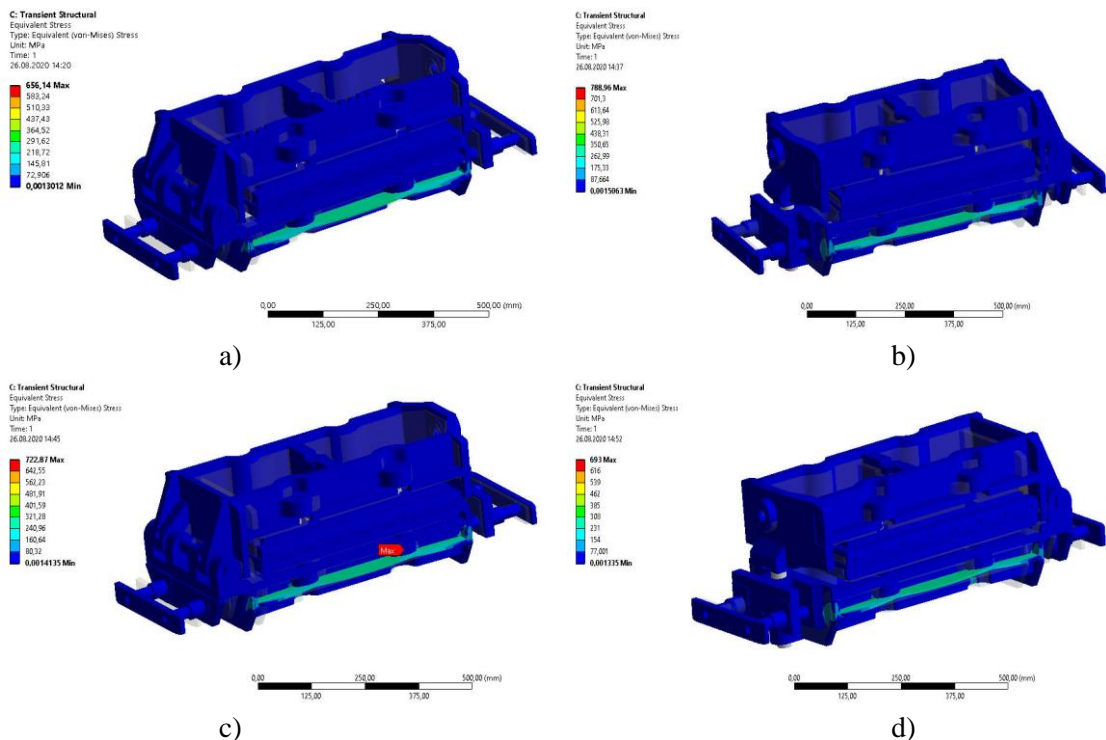

Fig. 7. Equivalent stress distribution a) GG25 b) GGG40 c) GGG45 d) GJV350

The stress values equivalent to the von Mises equivalence criterion of the mechanical stresses caused by thermal stresses and internal pressure effects in molds made of different materials are given in Figure 7. It is seen that the stresses remain in the range of 72-87 MPa in most parts of the mold, although there are locally high stresses. The specified values are at the limit of safety for all materials, it is seen that the stresses of 87 MPa occur in GGG40 material, and the stress of 72 MPa occurs in the mold made of GG25 material.

The high stresses seen in Figure 7 should be handled together with the deformations caused by thermal expansion presented in Figure 8. The reason for the high stresses mentioned is that the support plates next to the molds and made of structural steel are incompatible with the coefficients of thermal expansion with the main materials. When the molds expand, the side supports expand slightly, causing local stress formation. It is recommended to choose materials compatible with the main structure in order to eliminate the stated situation.

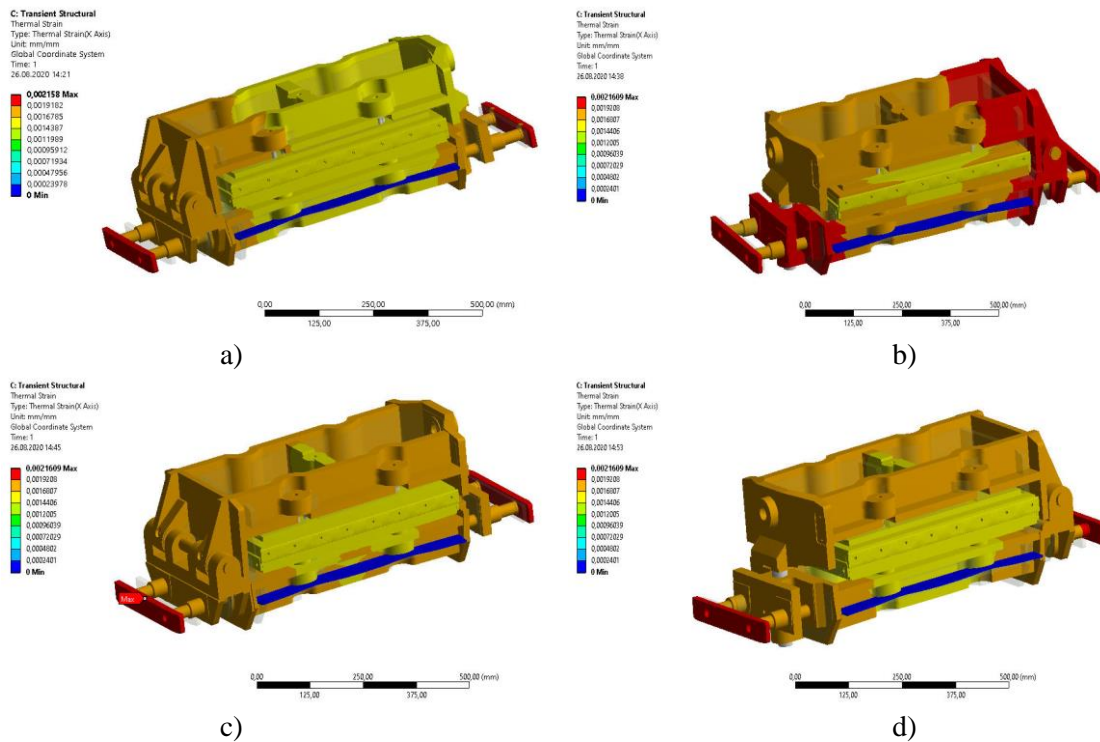

Fig. 8. Thermal deformation a) GG25 b) GGG40 c) GGG45 d) GJV350

CONCLUSION

In this study, the effects of temperature distribution and thermal deformations of four different materials (EN-GJS-400, EN-GJS-450, EN-GJL-25, EN-GJV-350) used in wafer baking mold were analyzed numerically. Proper boundary conditions are applied according to the literature and measurements.

As a result of the analysis carried out on the cooking molds, it was concluded that it is appropriate to use all the materials evaluated in the construction, that it maintains its structural integrity and can operate safely under the specified mechanical / thermal loads. However, it is considered that their performance can be improved as a result of the improvements to be made in the mold construction. Moreover, the support plates next to the molds made of structural steel are incompatible with the coefficients of thermal expansion with the main materials. It is recommended to choose materials compatible with the main structure in order to eliminate the stated situation.

ACKNOWLEDGEMENT

This study has been prepared from the project named "Research and Development of Wafer Baking Mold Set for Producing Quality Wafer Leaves" supported by Republic Of Turkey Ministry of Industry and Technology, KOSGEB Research-Development, Innovation and Industrial Application Program. Project no: 205719. Authors would like to thank Tüfekçiğulları Makine R&D Center, which is the idea owner and the manager of the project, and also the Karaman KOSGEB Provincial Directorate for financial support.

REFERENCES

- [1] Tiefenbacher, K. F.. The Technology of Wafers and Waffles I: Operational Aspects. Academic Press. 2017.
- [2] Manley, D.. Wafer biscuits. In Manley's Technology of Biscuits, Crackers and Cookies pp. 353-371 Woodhead Publishing 2011.
- [3] Anonymous 1 <https://en.baker-group.net/technology-and-recipes/technology-confectionery-industry/waffles.html>, accessed on 25.09.2020
- [4] Dogan, I. S. (2006). Factors affecting wafer sheet quality. International journal of food science & technology, 41(5), 569-576.
- [5] Sundara, R. (2012). The science behind the flat wafer baking process. New Food Magazine, 15(4), 56-60.
- [6] Tiefenbacher, K. F. (2018). The Technology of Wafers and Waffles II: Recipes, Product Development and Know-How. Academic Press.
- [7] Anonymous 2 <https://www.biscuitpeople.com/magazine/post/the-processing-of-flat-wafers-27-pre-baking-processes>, accessed on 25.09.2020
- [8] Macrae, R., Robinson, R. K., & Sadler, M. J. Encyclopaedia of food science, food technology, and nutrition. Academic Press. (1993).
- [9] Bergman, T. L., Incropera, F. P., Lavine, A. S., & DeWitt, D. P. (2011). *Introduction to heat transfer*. John Wiley & Sons.
- [10] Matthias, W. "Hot embossing: theory and technology of microreplication." William Andrew, Burlington, Massachusetts (2009).

AUTOMATION AND INDUSTRY 4.0

Stanko P. Stankov¹

¹University of Niš, Faculty of Electronic Engineering, Niš, Serbia
e-mail: stanko.stankov@elfak.ni.ac.rs

Abstract: For many years, *Industry 4.0* has been a popular topic related to the application of digital technologies in various manufacturing processes. The basis of this concept is the acquisition and analysis of data from propulsion equipment, which enables the realization of faster, more flexible and more efficient production. The result is high quality products, cost reduction, increased production, changing labor profile, increasing the competitiveness of the country's economy. The fourth industrial revolution is characterized by smart factories and plants that are adaptable and efficiently integrate customers and business partners, with an emphasis on full automation. This is possible due to the increasing reduction of barriers between the elements of automation and communication and information technologies. Modern process automation means optimizing the quality of products, increasing safety at work, reducing unplanned downtime in production, efficient use of available resources, meeting strict environmental requirements. Improving technology consists of mass production, which saves energy, resources and labor. The following technical and technological elements essentially represent *Industry 4.0*: big data, autonomous robots, software for the development of simulation models, universal system integration, industrial internet, cyber security, cloud computing, additive production and augmented reality.

Key words: process control, internet of things, *cloud computing*, additive technologies, digitization of processes

INTRODUCTION

Increasing production and reducing costs are the driving force in the development of industry and various technical - technological disciplines. Every revolutionary innovation in industry makes a great contribution to increasing the quality and production capacity of industrial enterprises on a global level. Nowadays, the global industry is in the process of intensive transition to *Industry 4.0*, a standard that implies a fully automated industry, in which the Internet of Things (*IoT*) platform enables more precise management of production and process activities, reduces production costs, minimizes errors and failures, thanks to systems for predictive maintenance, management and analysis.

Modern automation systems basically have a six-step model of industrial automation architecture, which is defined at Purdue University: level 5 - business system automation; level 4 - automation of production plant automation of production plant, enterprise resource planning (*ERP*) [1], production planning strategy (*MRP*) [2] and production process management (Manufacturing execution systems - *MES*); level 3 - automation of various branches of enterprises automation of various branches of the enterprises; level 2 - automation of machines and technological processes automation of machines and technological processes; level 1 - supervisory control systems; level 0 - sensors and actuators.

In the general case, the software is installed on PCs connected to levels 2, 3, 4 and 5. Levels 2, 3 and 4 usually have communication interfaces and databases in which data is buffered and information of individual levels and user interfaces is synchronized. This model of computer data processing is relatively complex, increases operating costs and complicates the administration process. This is also the reason for the tendencies that lead to the simplification of architecture.

The new controller models and devices in the field are in direct communication with all levels - from levels 0 and 1 to 4 and 5 levels, using appropriate communication protocols and especially WEB services based on Open Platform Communications Unified Architecture (*OPC UA*).

This tendency develops naturally and dynamically, since each new element of automation, as a rule, possesses a certain intelligence and richer functionality. This applies both to devices and equipment that are installed in the field - more intelligent sensors and controllers, and to equipment in operation - more powerful computer systems. The *Industry 4.0* initiative, *OPC UA* and the Industrial Internet of Things (*IIoT*) consortium also make a significant contribution to this direction of development [3]. The tight integration of field devices and corporate-level business systems is becoming increasingly important in increasing production efficiency - the next big step in the evolution of industrial automation.

Business production management systems such as those for enterprise resource planning - *ERP* or materials - *MRP* traditionally use a package architecture, which does not reflect the situation in real time [4]. This way naturally affects the quality of products, services and supply chains, and ultimately reduces the level of profit. Full automation of the company enables processing and monitoring of transactions in real time, which enables synchronized and timely operation. There are controllers that are in direct communication with the company's business systems using the *OLE* architecture - Object Linking and Embedding for Process Control. To achieve the set goals, we are also working on adapting existing industry standards such as *OPC*, *OPC UA*, *B2MML* (Business To Manufacturing Markup Language), *ERP* interfaces as well as those with *IT* (Information technology) databases. Digitization of products and services has a horizontal and vertical effect on the value chain, which means that the company must integrate processes and data flows from the procurement of raw materials and product development to technology, production and transport. In this process, it is necessary to network with suppliers, customers and other partners in a complex value chain. After the steam engine, conveyor belt, electronics and the Internet, there is now talk of 6 "Industry 4.0" - the fourth generation of industry characterized by the networking of smart digital devices. The characteristics of industrial revolutions are shown in Fig. 1 [5, 6].

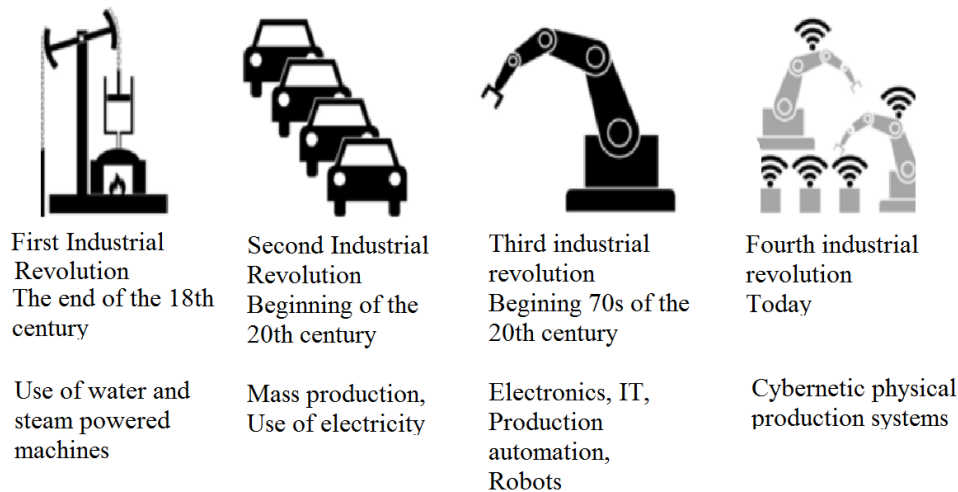

Fig. 1. Basic characteristics of industrial revolutions

Condition maintenance (maintenance based on the forecast or predictive maintenance) is a way of anticipating possible problems in the plant and undertaking activities in order to neutralize those problems. Developed analysis systems can drastically improve the finding of solutions that will contribute to the precise conduct of the production process. Related to this are modern business models based on newly promoted services and new technologies. Countries differ in terms of digitalization goals, although companies around the world are largely in the vortex of *Industry 4.0*, with regionalization of their goals being observed: corporations in Japan and Germany use digitalization mainly to increase production efficiency and product quality.

In the USA, there is a trend of developing new business models with the maximum acceleration of digital offers and services. Enterprises in China place emphasis on strengthening their position in relation to international competitors through cost reduction. Some research predicts that most regions will be at almost the same level of digital integration within five years, and that some countries such as Japan, Germany and the United States will still be at the forefront [6, 7].

LARGE VOLUME OF DATAV EXCHANGE, ANALYSIS, OPTIMIZATION, CLOUD COMPUTING SERVICES

The development of automation is accompanied by a constant increase in the set of data used in the analysis and optimization of automated processes in order to increase productivity and production efficiency. The amount of information is constantly increasing due to the installed devices that generate real-time data. *The Cloud Computing* platform enables companies to access the *IT*

infrastructure (servers, data storage equipment, etc.) and various fully developed software business applications via the Internet. An important feature of cloud architecture is flexibility in relation to users, which allows small and medium enterprises to keep pace with the constant change of technologies with their relatively limited *IT* resources [8].

OPC UA is the only open communication protocol so far, created on the basis of standards adopted in computer technology, which connect industrial software, controllers and sensors with corporate business systems, which enables increased productivity and creates conditions for the realization of a digital factory. *OPC UA* creates the possibility of efficient and reliable communication infrastructure - from sensors to corporate management system at all levels of production automation, *SCADA* system and process management. *PLC* (programmable logic controller) open *OPC UA* functional blocks are extensions of the IEC 61131-3 standard that traces the path to the IEC 61131-3 software model and the *UA* information model [9].

GSM devices are increasingly being used instead of remote monitoring systems. The implementation of techniques for connection to cellular networks, which are constantly being improved, and the sending of short texts (*SMS*) to controllers have been increased. The development of this area also includes technologies such as the Internet, cloud computing, software with various functions as well as *IP* (Internet Protocol) video and audio communications

APPLICATION OF COLLABORATIVE ROBOTS

Robotics is the basis of the 4th industrial revolution. The question arises as to why these robots are different from those that have been used for ten years or more in various branches of industry (automotive industry, shipbuilding, military industry, pharmaceutical industry, etc.). The difference is that today robots and humans have become equal partners - robots now have a higher degree of artificial intelligence in a networked factory and can communicate with machines and workers via smart devices. Machines communicate with semi-finished products, and individual parts of machines with each other.

The robots have built-in sensors - each individual joint of the robot has a sensor and responds to the slightest touch. If a glass of water is suddenly placed in front of the robot's hand, it will slowly slow down its movement so that not a drop is spilled. With that collision hazard recognition, human-robot collaboration is now possible. Until now, people and robots in the halls have always been separated by fences. Modern robots now work closely with humans. The development of robots goes in the same direction as with PCs - the goal is to produce at the lowest possible cost during operation, with at the same time greater power and functionality, which makes robots suitable for performing a number of tasks in the industry.

Collaborative robots safely and efficiently assist workers in the production process, with no need for experts to program, install and maintain them. Installing and configuring these robots is intuitive and does not require much time. Robots can be switched off during idling while waiting for processing materials, which can save up to 15% of the energy now consumed in the production process. In addition, their price is several tens of thousands of euros, and the efficiency and time of exploitation enable a quick return on investment. These robots provide optimal speed, high precision and safety at work. Nowadays, new generations of robots are appearing on the market, which are more compact and work in a working environment with workers. Their prices are significantly lower compared to the prices of conventional industrial robots and are very interesting for relatively small production plants [10, 11].

INTEGRATED DESIGN

Recently, the design of various products, machines and production processes has been intensively and dynamically developed. At the same time, we are working on the development of efficient management systems. A key component of this concept is simulation software, which is becoming increasingly accessible and easy to use. The goal is to create software that will enable the design of products, production processes and automation platforms, with the idea of enabling the verification of these projects through simulation before physical realization. The simulation enables the cooperation of designers of production processes and automation, which contributes to the relatively easy adoption

of new technologies, while improving product quality, increasing the level of production and ultimately the profit of the plant.

Control and supervisory systems can be developed in the direction of software and system-oriented architectures, which are based on devices for analysis, modeling, design and evaluation of human-machine interaction, including methods that enable modeling of human behavior, real and virtual environments for simulations, complex methodologies design, task assignment, etc. Advances in modern human-machine systems in process automation include intelligent *HMI* (Human-Machine Interfaces) devices for operator navigation, automatic generation of machine control programs, various trends and graphics, as well as training programs based on ready-made functional modules and blocks. The global transformation of industrial automation is in full swing. An increasing number of connected devices, unlimited Internet access, permanently growing *IT* infrastructure are prerequisites for the development of new business potentials [12, 13, 14].

ADDITIVE TECHNOLOGIES AND 3D PRINTING

Advances in the field of additive methods have enabled the development of *3D* printing - modern technology in the production of three-dimensional objects. *3D* printers are widely used to make prototypes and even regular products, which allows production at far less cost compared to conventional technologies. Another advantage of additive technologies is reflected in the fact that a single machine can produce a large number of different products, which is practically impossible with traditional production lines. At the same time, *3D* printing enables the creation of very complex shapes and structures that would not be profitable in classic production. This is likely to lead to radical changes in the way a wide range of industrial products are designed, developed and manufactured.

The technique of *3D* printing has found application in the military industry. The US military printed a spare part for the *F-16*, and the British for the *Tornado* [15].

The principle of operation of *3D* printers is similar to the operation of ordinary printers - printing takes place in a plane, except that not one layer is printed but the appropriate number of layers to get the third dimension. Graphic *3D* software packages are used to design the element to be created as the final product. The printer driver converts this model into layers. A simple presentation does not reflect all the complexity of this procedure. One of the first materials used for these purposes (along with liquid photopolymers that harden) is ceramics. Various powders are used as raw material for *3D* processes. Since materials have different properties, certain technologies cannot be used for certain types of materials. It should be expected that with the further advancement of *3D* technology and printers, as well as the materials used in the production of samples, there will be improvements and even greater efficiency and applicability of this technology [16].

INTERNET OF THING (IoT) PLATFORM IN INDUSTRIAL AUTOMATION

The integration of IoT functionality in industrial automation has significantly reduced operating costs, contributed to the optimization of production process time, energy and resource use. In this context, the *Internet of Thing* is a set of physical objects or devices that connect to the Internet using embedded technologies and have the ability to observe, measure and interact with other things around them.

The realization of an intelligent production infrastructure, based on the IoT platform, provides owners and managers of industrial plants with information related to production and business at any time and at any point. Data on the operation and functionality of equipment are the starting point in optimizing productivity, developing process control, increasing energy efficiency, safety at work, reliability and flexibility of industrial production.

The *IoT* platform basically has sensors and devices with a relatively low price and low energy consumption, which contributes to a significant reduction in costs in modern industrial production. This technology enables direct communication between sensors, devices and infrastructure in the plant, which provides servers, operators and management with the necessary information about the operation and efficiency of the system [17, 18].

Cloud platforms, intelligent buildings, the current development of automation in construction and industry, the possibility of acquisition, processing and storage of extremely large amounts of data (big

data) and other technological innovations in this area have accelerated the development of the concept of industrial Internet elements - *IIoT*.

NEW STRATEGIES AND TECHNOLOGIES

According to *Berg Insight*, the number of automation systems is constantly increasing globally. At the same time, the number of interconnected devices and the amount of collected data to be processed is increasing. This results in the need for new, more powerful management systems to fully exploit the potential of the data collected. About ten years ago, there was a significant difference in the price of technical means (especially controllers and accompanying equipment) of various manufacturers.

Recently, there are differences in the price of processors, memory, *embedded* software, communication components, etc. they become minor. Conventional processes and technologies, which have had a satisfactory performance in the industry for a relatively long period of time, are already becoming inefficient. The transition to *Industry 4.0* requires new strategies and technologies, which will reduce the time and effort to perform industrial operations. Renowned experts believe that in addition to technological innovations, work will have to be done on improving the system for data acquisition, processing and analysis, and that the problems related to that will be solved in the *IoT* environment.

The growing role of automation in the realization of industrial production and the "transfer" of increasing human rights and tasks to automated equipment and robotic systems represents a huge potential for more precise control and increased production efficiency. For the application of *IoT* in industrial automation, a new generation of controllers and sensors has been developed, with advanced capabilities and increased intelligence, which enables more precise management and efficient operation with a minimum of downtime. The main challenge of today's development of process automation is the design of complex and global decentralized systems. This requires new methods and techniques of modeling, improving the design and functionality of control - monitoring systems, the ability to manage complex networks with a large number of interconnected control systems and the coordination of many autonomous network elements.

DEVELOPMENT OF COMMUNICATION TECHNOLOGIES AND PROTOCOLS

The evolution of communication technologies has a decisive role in the transformation of the structure of industrial automation systems. Until recently, plant automation was based on the concept of Computer Integrated Manufacturing (*CIM*). In such a hierarchical structure, certain devices are designed for specific tasks and use specific network connections.

With the development of technology in this area, devices are becoming multifunctional, the intelligence of devices and equipment is increasing, and there is a need for modular devices. For example sensors, which are traditionally used to measure certain process variables, are increasingly being integral parts of monitoring and predictive maintenance systems in modern process automation. It is noticed that the traditional hierarchical concept of process management is becoming insufficiently functional, and its place is taken by decentralized distributed architecture.

Industry 4.0 integrates modern information technologies with conventional physical production and processes, enabling the development of new markets and business models. *Industry 4.0* is thus oriented towards integration and the provision of services that the individual customer is willing to pay for [19]. *Industry 4.0* is projected to transform the industrial workforce by 2025. According to research in Germany, the introduction of digital industrial technologies will create more jobs than jobs that will cease to be needed, with new jobs requiring significantly different workers. Detailed modeling predicts an increase of about 350 000 jobs in Germany by 2025.

Namely, the increased use of robotics and information technologies will reduce the number of jobs by about 610.000 in assembly and production, which will be compensated by the creation of about 960.000 new jobs, especially in the *IT* sector and data science. For this country, Fig. 2 illustrates the gross revenues of certain industries for 2013. and forecasts for 2025 [20].

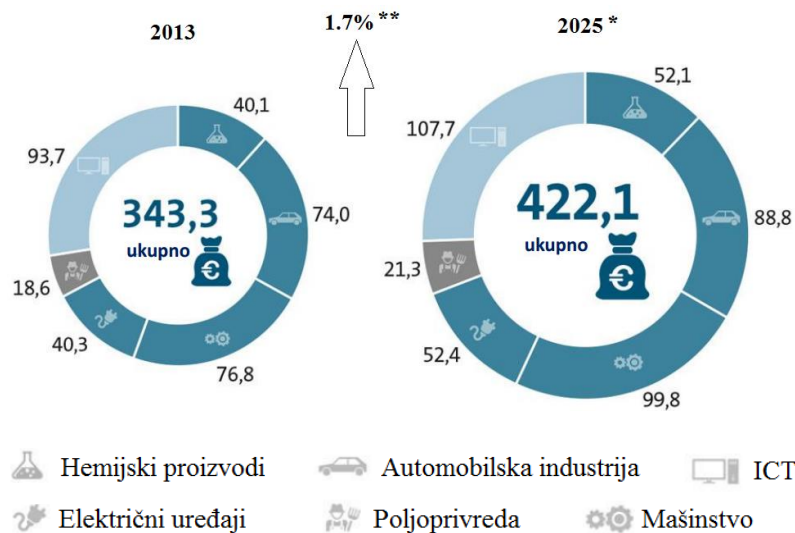

Fig. 2. Gross revenues (in billions of €) in individual sectors in Germany

DATA TRANSFER

The increasing speed of data exchange has imposed the need for mass use of Ethernet technologies in industrial networks. This also applies to wireless architectures that are increasingly present in the process industry. They can integrate remote, geographically remote measuring elements and devices in the field, have flexibility, are easy to install and operate, enable visualization, remote configuration, diagnostics and control. Another leading trend, in terms of communication in process automation, is the integration of interfaces that support the transfer and exchange of various types of device data - data from process measurements, control signals, various diagnostic data, monitoring data, hierarchical information and more. In order to respond to the needs and challenges of the modern process industry, it is necessary to implement horizontal and vertical integration of information and communication technologies as well as automation systems in the entire structure of the industrial enterprise. This can be achieved by efficiently integrating various processes into a single platform and connecting all individual subsystems.

CONTROL WITH THE USE OF PREDICTIVE MODELS

Model predictive control - *MPC* is already a standard solution in process control in the industry. There are mainly two models of predictive control - linear and nonlinear. The main advantage of this control method is the possibility of regulating multivariable systems, which have numerous limitations of input and output values. Solutions in the field of process control and automation of fourth generation *MPC* technologies are available on the market, which enable parallel optimization of a number of levels, priority realization of control tasks, improvement of product quality and efficient use of resources. There are also various advanced identification devices based on error and fault prediction methods. This concept is used in various fields including the chemical industry, food, oil and gas processing plants, the pharmaceutical industry, the rubber industry and a number of other sectors.

The development of optimal control of nonlinear systems, estimation of status and parameters, as well as stability analysis and synthesis of nonlinear systems are also part of the field of predictive control. Modern solutions of predictive control systems enable decentralized control and horizontal integration of global nonlinear processes that can be connected by a network, as well as the application of hybrid discrete - continuous control systems.

In process automation the application of artificial intelligence is increasing, especially in the field of product quality control, where slight improvements in process management can lead to significant advantages over the competition. The most important thing of technologies based on artificial intelligence in the industry is real-time process control and resource planning and management where their further development and mass application is yet to come. Monitoring of the production process, the possibility of forecasting failures, unplanned downtimes and accidents, are key elements for

increasing efficiency. The basic task of the management system is to enable product quality, safety and security of people and equipment. The consequences of unplanned and unwanted events due to various causes lead to a drastic increase in costs, to the interruption of the production process in a certain period with significant negative effects on the reliability and economy of the company, as well as on its image. The more complex the control process, the more complex the monitoring and diagnostics that will prevent the occurrence of failures and breakdowns. In modern process automation, based on knowledge of the nature of the controlled process, there are two methods: one is based on previous process modeling, which includes various quantitative and qualitative simulation methods and predictive calculation of values of certain variables of systems over time; the second method is based on the experience and historical data of the managed process with the application of quantitative, qualitative and statistical methods. The development of automation and information technologies in the process industry and the increase of its complexity and intelligence have resulted in the generation of a huge amount of data and the need for their processing and analysis. At the same time, the need for the number of executors engaged in management processes has decreased. Today, operators are faced with very responsible tasks in terms of taking action in certain critical or crisis situations, when it is necessary affect quickly and energetically.

For these reasons, they need processed and easily accessible relevant data. Therefore, the basic tendency in process control is the integrated connection of management, knowledge and information. This development is based on in-depth research into the interrelationships that exist between humans and machines in the production process, covering all possible technical and social aspects of that communication, as well as all activities in which people control or supervise machines, equipment or complete technological processes.

DIGITAZION OF PRODUCT AND SERVICE PORTFOLIOS

Industry 4.0 goes far beyond process digitization. This revolution is leading to a greater degree of digitization of product and service portfolios. The perfect mechanical properties of one product are no longer enough to compete on the world market. The advantage is on the side of digitized products with built-in sensors, software, the ability to generate data and network. Digital products are phenomena that can be found in all branches of industry. For example in the automotive industry, instead of classic braking systems, *ABS* (Anti-lock braking system) devices with implemented modern control systems are installed. It is an electro-hydraulic system that prevents the wheels from locking when braking, which usually happens when braking very hard or when driving on slippery sur the risk of blocking the wheels. In production and engineering, the use and connection of appropriate sensors enables optimal maintenance of machines and provides efficient operational control. It is understandable that the percentage of digital products is the highest in the information and communication technology sector. In the manufacturing industry, the degree of digitization is currently between 22 % and 27 %. The general tendency of all sectors is an intensive increase in the level of digital products and services in the coming years. At the core of *Industry 4.0* is the complete digitization of processes, products and services and integration into digital ecosystems with value chain partners.

CONCLUSION

The perspective of automation is considered with special reference to *Industry 4.0*. Various corporations around the world are projected to invest more than \$ 1000 billion a year by 2022 in the conquest of *Industry 4.0*, which will lead to a significant reduction in costs, increased efficiency and profits, and it is predicted that the investment will pay off in two years, with the need for *IT* experts to increase permanently. In the countries of the developed world, it is estimated that one third of their companies have a high level of digitalization, and it is expected that this percentage will reach the value of 75 % in the next five years. Worldwide, large companies are investing 5 % of their digital sales revenue annually, or approximately \$ 907 billion, which will be further invested in digital technologies such as sensors and various devices, and in the development of software and applications such as production management systems. It is believed that in the next five years, data analysis will have a major impact on decision-making processes. *Industry 4.0* is based on the smart factory model

that integrates the knowledge and skills of participants at all levels (scientific corps, managers, engineers, workers). The basic features of a smart smart enterprise are: smart personalized product, unified role of manufacturers and service providers (offer of extended products - integration of products and services), high level of cooperation at the level of business system and environment. The essence of the vision of *Industry 4.0* and *IoT* is a versatile connection of people, products, machines and equipment in the production plant in order to realize new products and services.

Products, transport system and devices will be able to "negotiate" within the virtual market regarding the most efficient steps that would allow maximum efficiency of the production process. This would provide a connection between the virtual world and the physical objects of the real system. In the last 15 years, progress has been evident in the development of additive technologies (*3D printing*), which has significantly increased the potential for design, development, production and distribution of certain products. This progress is e.g. in the automotive industry opened the door to innovative technical solutions that have contributed to cleaner, easier and safer production, shorter delivery times and reduced costs. It is a question of the near future when *3D printing* will begin to be used not only for prototyping but also for innovative elements in mass serial production.

REFERENCES

- [1] Marianne, B., *Modern ERP: Select, Implement, and Use Today's Advanced Business Systems* Third Edition, 2020.
- [2] Guillermo, G., *IEOR 4000: Production Management*, 2015.
- [3] Gilchrist, A., *Industry 4.0, The Industrial Internet of Things*, 1st edition, 2016.
- [4] Moustakis, V., *Material requirements planning-MRP*, Technical University of Crete, 2000.
- [5] Griffin, E., *Liberty's Dawn: A People's of the Industrial Revolution*, 2014.
- [6] Popkova, Ragulina, E., Bogoviz, J., Aleksei V., *Industry 4.0: Industrial Revolution of the 21st Century*, 2019.
- [7] http://www.acatech.de/fileadmin/user_upload/Baumstruktur_nach_Website/Acatech/root/de/Material_fuer_Sonderseiten/Industrie_4.0/Final_report_Industrie_4.0_accessible.pdf
- [8] Theobald, O., *Machine Learning For Absolute Beginners: A Plain English Introduction (Second Edition)*, 2017.
- [9] http://www.dee.ufrj.br/controle_automatico/cursos/IEC61131-3_Programming_Industrial_Automation_Systems.pdf
- [10] <http://www.assemblymag.com/articles/91862-human-robot-collaboration-comes-of-age>
- [11] Hoffman, G. & Breazeal, C., *Collaboration in Human-Robot Teams*, MIT Media Lab, 20 Ames St. E15-468, Cambridge, MA, 02139, USA, 2004.
- [12] <http://www.cumulocity.com/?gclid=CN-i6aGU5MsCFXEz0wodVHMMKQ>
- [13] <http://www.cumulocity.com/?gclid=CJWPxt2U5MsCFRIUGwodXegKpQ>
- [14] https://en.wikipedia.org/wiki/Internet_of_Things
- [15] Hoffman, M., *British Fighter Flies with 3D Printed Parts*, Defensetech, 2004.
- [16] Vujović, I., Šoda, J., Kuzmanić, I., Utjecaj tehnologije 3D tiskanja na raspoloživost brodskih sustava, Pomorski fakultet, Sveučilište u Splitu, "Naše more" 62(4)/2015. – Supplement, pp. 93-96, 2015.
- [17] Tsiatsis, V., Karnouskos, S., Holler, J., Boyle, D., Mulligan, C., *Internet of Things, Technologies and Applications for a New Age of Intelligence*, 2nd Edition, 2018.
- [18] <http://www2.deloitte.com/content/dam/Deloitte/ch/Documents/manufacturing/ch-en-manufacturing-industry-4-0-24102014.pdf>
- [19] https://bib.irb.hr/datoteka/830372.Lean_Spring_2016_prezentacija.pdf
- [20] <https://www.pwc.com/gx/en/industries/industries-4.0/landing-page/industry-4.0-building-your-digital-enterprise-april-2016.pdf>

DYNAMIC MODELLING AND CONTROL OF A REACTION WHEEL INVERTED PENDULUM USING MSC ADAMS AND MATLAB

Abdullah Çakan¹, Ümit Önen²

¹Department of Mechanical Engineering, Faculty of Engineering and Natural Sciences,
Konya Technical University, Konya, Turkey

²Department of Mechatronics Engineering, Faculty of Engineering and Architecture,
Necmettin Erbakan University, Konya, Turkey
e-mail:acakan@ktun.edu.tr

Abstract: In this study, control of a reaction wheel inverted pendulum system is modelled in virtual prototyping environment is proposed. Virtual prototype of the reaction wheel inverted pendulum is created using several softwares. Firstly, the system is created by using SolidWorks and imported to MSC Adams, afterwards the control plant model is exported to MATLAB for design the controller and apply the system. A PID controller (Proportional-Integral-Derivative) is designed and applied for the purpose of balance control of the system. The results show that modelling and control the reaction wheel inverted pendulum is successfully achieved the control simulations. Results are given in the form of the graphics.

Key words: modelling, control, reaction wheel, inverted pendulum, simulink, mscadams, co-simulation.

INTRODUCTION

Inverted pendulum systems are widely studied in control systems area to compare control techniques as a benchmark problem. There are many different inverted pendulum types such as rotary inverted pendulum, single or double link cart pendulum systems and the reaction wheel inverted pendulum [1-4]. In this research, reactional wheel inverted pendulum system is studied. Reaction wheel is a flywheel that is used in many systems such as satellites attitude controls, drive the robots and vibration control systems [5-8]. The Reaction wheel inverted pendulum also known as inertia wheel inverted pendulum is a pendulum system consist of a rotating wheel on top and a simple inverted pendulum rotating about a pinned joint. Also, many control techniques are studied using these different type inverted pendulum systems [9-11]. PID controller is very comprehensive and effective that's why it is commonly used. Therefore, a PID controller is applied to balance the pendulum in this research. PID controller is implemented to the system by using MSC Adams and Matlabco-simulation. MSC Adams is an effective way to modelling the mechanical systems and exporting the control plant to the Matlab/Simulink [12].

MODELLING AND CONTROL

In this section modeling and control of the reaction wheel inverted pendulum system is described. CAD model of the system is designed on the basis of [13] by using SolidWorks. Designed reaction wheel inverted pendulum system is shown in Figure 1. and the system parameters are shown in Table 1.

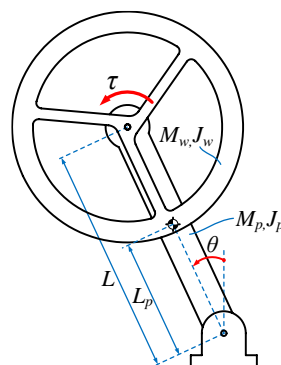

Fig. 1. Reaction wheel inverted pendulum system.

Table 1. Reaction wheel inverted pendulum system parameters.

M_w	Mass of reaction wheel	0.554 kg
M_p	Mass of pendulum	0.141 kg
J_w	Wheel mass moment of inertia	$4.36 \times 10^{-3} \text{kgm}^2$
J_p	Pendulum mass moment of inertia	$0.69 \times 10^{-3} \text{kgm}^2$
L	Pendulum length	0.21 m
L_p	Pendulum center of mass length	0.11 m
τ	Control torque	Nm
θ	Pendulum angle	degree

Designed CAD model is imported to MSC Adams that is a multi-body modeling software to build and simulate mechanical systems dynamic analysis. Therefore, equation of motion of the reaction wheel inverted pendulum is not used to simulate the system. The reaction (inertia) wheel inverted pendulum consist of a reaction wheel on top and a simple inverted pendulum rotating about a pinned joint. Control torque is applied to the reaction wheel as input to balance the pendulum for the desired position as output of control system using Matlab/Simulink and MSC Adams co-simulation. Pendulum angular velocity and wheel angular velocity values also defined as outputs of the system. Control system of the reaction wheel inverted pendulum is shown in Figure 2.

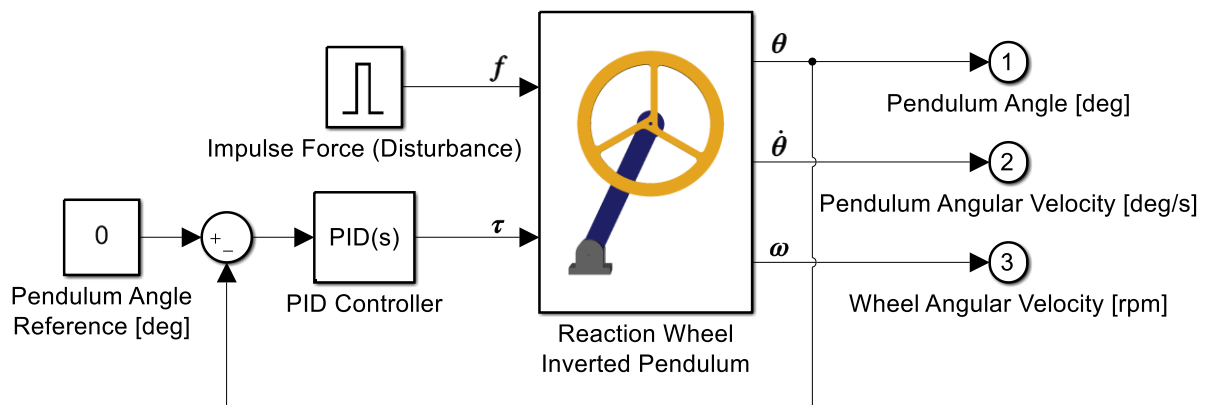

Fig. 2. Control block diagram of MSC Adams and Matlab co-simulation.

As seen in the control block diagram, an external force applied as disturbance in the 4th second and the results are realized. Disturbance impulse value is 0.5 N-s and details of the disturbance shown in Figure 3. Initial position of the pendulum is -25 degree and pendulum angle is controlled to balance pendulum vertically using manually tuned (trial and error) PID controller, according to system response and PID constants determined as $K_p=5$, $K_i=0.05$ and $K_d=1$.

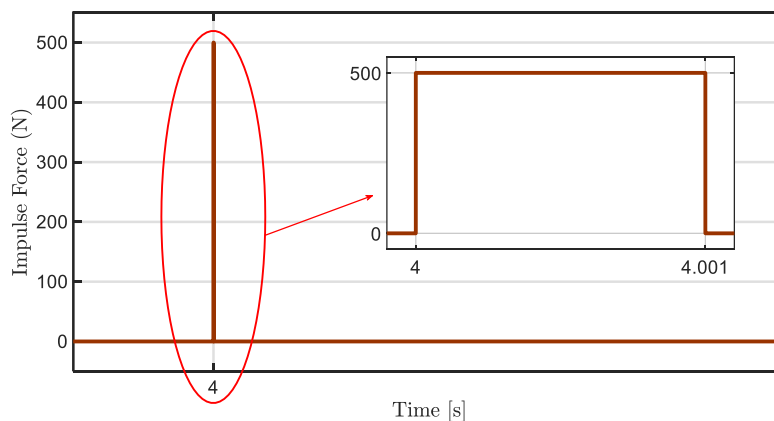

Fig. 3. 0.5 N-s impulse disturbance applied to the center of reaction wheel.

RESULTS AND DISCUSSION

Desired pendulum position is 0 degree both in the beginning of the simulation and in the 4th second when the disturbance is applied. PID Controlled pendulum position response is shown in Figure 4. As seen in the figure PID controller successfully achieved the desired position of the pendulum in less than one second. Moreover, Pendulum angular velocity and wheel angular velocity are also realized and given in Figure 5. and Figure 6. respectively. Control torque output of the PID controller (control input of the reaction wheel inverted pendulum system) is shown in Figure 7. Snapshots of the MSC Adams simulation is shown in Figure 8. In order to see the results clearly time axis of the figures are widened.

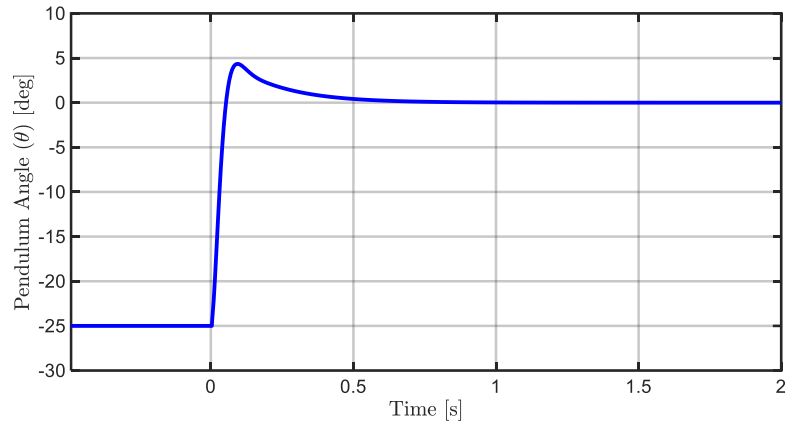

Fig. 4. Pendulum angle response of the system.

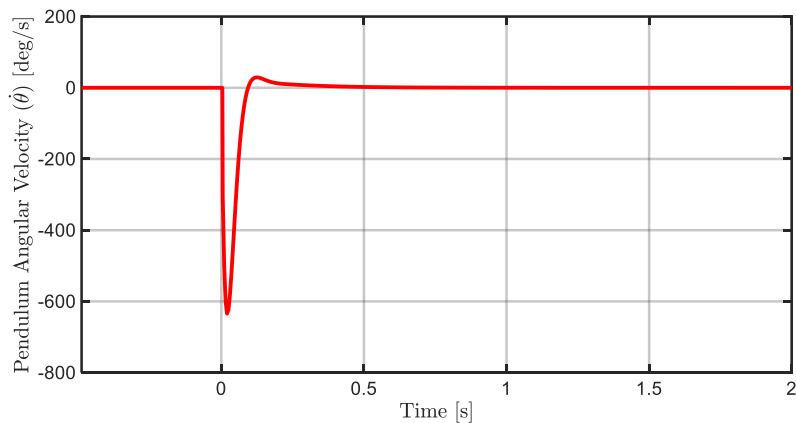

Fig. 5. Pendulum angular velocity response of the system.

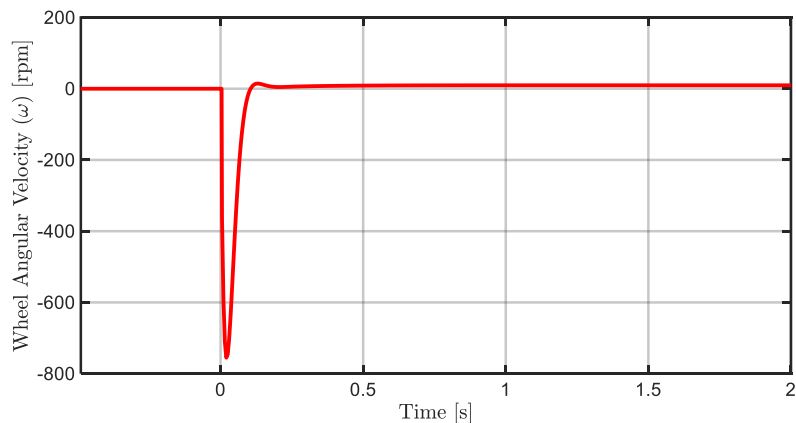

Fig. 6. Reaction wheel angular velocity response of the system.

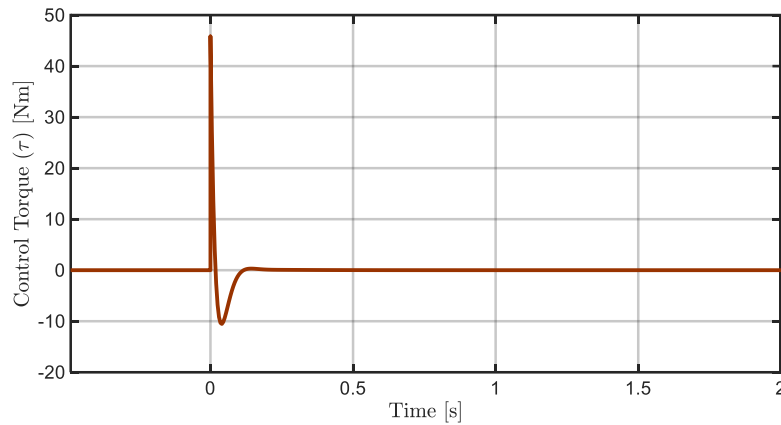

Fig. 7. Control torque for the balance the system -25 degrees to 0.

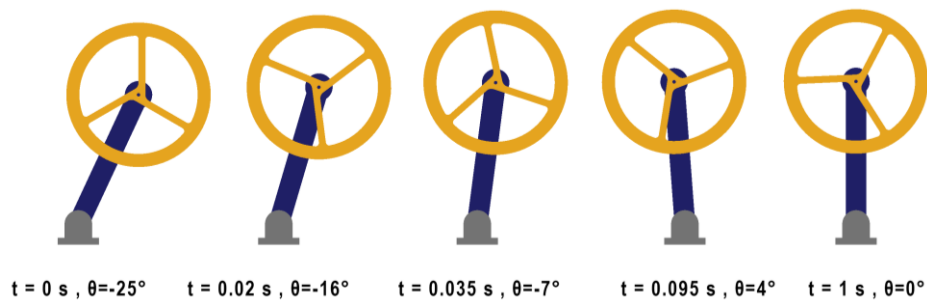

Fig. 8. Snapshots of MSC Adams simulation -25 degrees to 0.

As mentioned in previous paragraphs 0.5 N-s impulse is applied to the center of wheel of the inverted pendulum system in the 4th second after the balanced from the initial position -25 degrees. Pendulum position response after the disturbance impulse is shown in Figure 9. and the snapshots of MSC Adams simulation is shown in Figure 10.

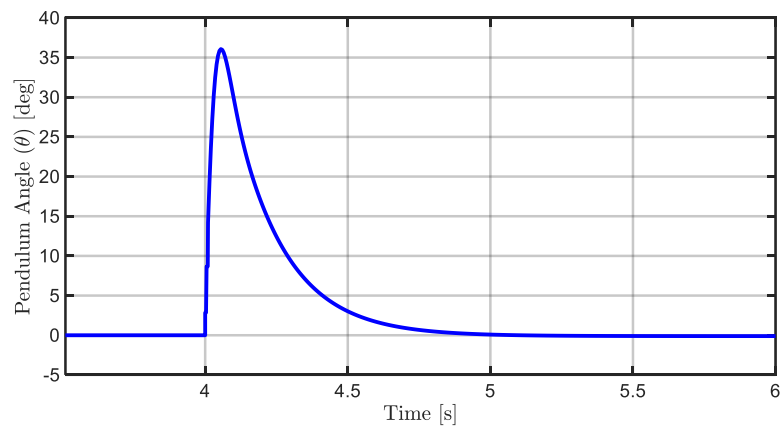

Fig. 9. Pendulum position response after the disturbance.

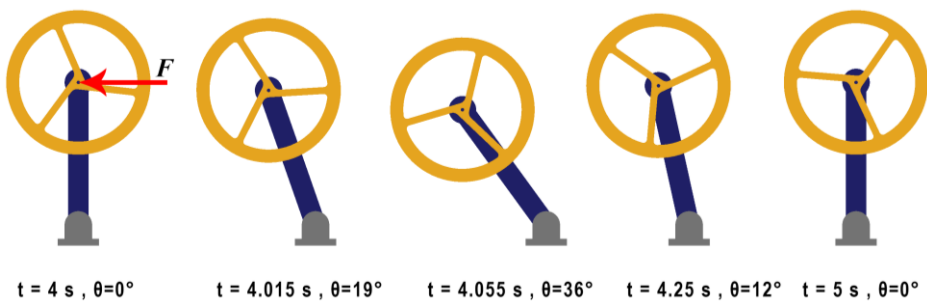

Fig. 10. Snapshots of MSC Adams simulation after the disturbance.

CONCLUSION

The paper presents virtual prototyping approach of a reaction wheel inverted pendulum system. Virtual prototyping make easy modelling mechanical systems without using equation of motions. Designed system using SolidWorks is imported to MSC Adams, inputs are outputs are derived to create control plant and exported to the Matlab/Simulink to run combined model and apply PID controller. PID controller gains are manually tuned (trial and error) to balance the pendulum in the vertical position applied, (0 degree) both beginning of the simulation and after applied the disturbance impulse. Controller is successfully achieved desired pendulum position. According to results, co-simulation method is an effective and easy way to modelling the control systems. For the better results optimization algorithms can be used to determine PID gains or different control techniques can be used. Furthermore, this study can be a reference to the modelling and control studies of the mechanical systems especially different type of pendulum systems for the future works.

REFERENCES

- [1] M. Roman, E. Bobasu, and D. Sendrescu, Modelling of the rotary inverted pendulum system, in 2008 IEEE International Conference on Automation, Quality and Testing, Robotics, vol. 2, pp. 141-146: IEEE, 2008.
- [2] M. Muehlebach and R. D'Andrea, Nonlinear Analysis and Control of a Reaction-Wheel-Based 3-D Inverted Pendulum, IEEE Transactions on Control Systems Technology, vol. 25, no. 1, pp. 235-246, 2017.
- [3] Ü. Önen, A. Çakan, and İ. İlhan, Performance comparison of optimization algorithms in LQR controller design for a nonlinear system, Turkish Journal of Electrical Engineering & Computer Sciences, vol. 27, no. 3, pp. 1938-1953, 2019.
- [4] A. Çakan, F. M. Botsalı, and M. Tinkır, PID Control of Inverted Pendulum Using Adams and Matlab Co-Simulation, presented at the Proceedings of the 4th International Conference on Control, Mechatronics and Automation - ICCMA '16, 2016.
- [5] F. Zhang, P. Washington, and D. A. Paley, A flexible, reaction-wheel-driven fish robot: Flow sensing and flow-relative control, in 2016 American Control Conference (ACC), pp. 1221-1226: IEEE, 2016.
- [6] L. Jae-Oh, H. In-Woo, and L. Jang-Myung, Fuzzy sliding mode control of unicycle robot, in 2011 8th International Conference on Ubiquitous Robots and Ambient Intelligence (URAI), pp. 521-524: IEEE, 2011.
- [7] Z. Ismail and R. Varatharajoo, A study of reaction wheel configurations for a 3-axis satellite attitude control, Advances in Space Research, vol. 45, no. 6, pp. 750-759, 2010.
- [8] X. Weber, L. Cuvillon, and J. Gangloff, Active vibration canceling of a cable-driven parallel robot using reaction wheels, in 2014 IEEE/RSJ International Conference on Intelligent Robots and Systems, pp. 1724-1729: IEEE, 2014.
- [9] M. Olivares and P. Albertos, Linear control of the flywheel inverted pendulum, ISA Trans, vol. 53, no. 5, pp. 1396-403, Sep 2014.
- [10] B. H. Nguyen, M. P. Cu, M. T. Nguyen, M. S. Tran, and H. C. Tran, LQR and Fuzzy Control For Reaction Wheel Inverted Pendulum Model, Robotica & Management, vol. 24, no. 1, 2019.
- [11] Y. Rizal, R. Mantala, S. Rachman, and N. Nurmahaludin, Balance Control of Reaction Wheel Pendulum Based on Second-order Sliding Mode Control, in 2018 International Conference on Applied Science and Technology (iCAST), 2018, pp. 51-56: IEEE, 2018.
- [12] T. Brezina, Z. Hadas, and J. Vetiska, Using of Co-simulation ADAMS-SIMULINK for development of mechatronic systems, in 14th International Conference Mechatronika, 2011, pp. 59-64: IEEE, 2011.
- [13] G. Belascuen and N. Aguilar, Design, modeling and control of a reaction wheel balanced inverted pendulum, in 2018 IEEE Biennial Congress of Argentina (ARGENCON), pp. 1-9: IEEE, 2018.

FORGE WELDING OF BIMETALIC AXE

Zoran Karastojković¹, Nikola Bajić¹

¹IHIS Technoexperts, Istraživačko razvojni centar, 11080 Zemun, Batajnički put 23.
e-mail: zoran.karastojkovic@gmail.com

Abstract: Today, we used to say that bimetalic products belong to the new era, produced only by a high-tech procedure. Here will be shown one product manufactured on a really primitive but successful way, made from one structural and tool steel. Joining of two different steels here is explained by forge welding. For the body of an axe commonly is used a kind of softer structural steel, about 0,30%C, while for a cutting edge must be used an insert from high carbon tool steel with more than 0,70%C.

The practice of this kind of welding needs very skill forgers. Another disadvantages of this technology is in very low productivity. But, instead of these, the forging and forge welding were applied over centuries ago in producing very qualitative tools and arms (*cold weapons*). The skills and technical demands from this kind of producing are not fully known to the contemporary welders or engineers, especially the benefits from a protective atmosphere that charcoal could provide.

In fact, forge welding does not need an electrical current (direct or alternate), induction heating up, laser beam, shielding atmosphere (argon or vacuum), etc., but only a wood charcoal, coke or gas fuel, and many practical experiences in temperature determination during heating up, handy strikes and speedy movements. The using of an appropriate flux also is needed. At the end, some knowledge and experience are desired in heat treating of tool or an axe, it means in quenching and tempering.

After forge welding is done, very qualitative joint is achieved, first of all it means the fusion and interface lines, which here are approved by metallographic view.

Key words: tool, axe, low- and high carbon steel, forge welding

INTRODUCTION - HISTORICAL BACKGROUND ON FORGING

Forging is undoubtedly the oldest deformation process. At the beginning, the noble metals as silver and gold were deformed, firstly by forging and further by drawing and/or rolling. Very few works were dedicated to the forge welding on the engineering manner, even today.

Forging welding was used in past for producing the wheels for wagons: the steel strip is heated up, bended and forge welded into ring shape, then is mounted on a circular wooden wheel structure. The heat affected zone is present in almost of contemporary welding techniques, but it could be said to be unknown term in forge welding.

Forging and generally fire have taken a very important role in almost civilizations all over the world. One of the most known gods is Hephestus, from ancient Greek, Fig. 1a). The principle of forging in its nature is very simple: the shaping of metal is provided by using localized forces, almost. Traditionally, forging is performing by using hammer and anvil, earlier is provided by hand strikes. The most valuable pieces from industry and elsewhere (hand tools, jewelry, etc.) still are producing by forging, because they are stronger than casted and machined piece.



Fig. 1. Hephestus - ancient Greek's god of forging & fire a) and forging fire b)

FORGING FIRE

Forging fire has a pretty long history. Small number of steels may be forged in the cold state; it means that almost of steels should be forged in the warm or hot state. Heating up was provided by using a forging fire by using a charcoal. In nowadays the heating up is rather provided by using a coke or gas fuel (propane or propane mix) for easier achieving the high temperatures. The most important advantage of forging fire lies in ability for producing very desired reduction atmosphere, for preventing the decarburization of steel.

The disadvantages of using a forging fire are in limited length (or volume) of heated part, Fig. 2a), and at low productivity for the contemporary sence of production. The equipment for forging fire is pretty simple, Fig. 2b).

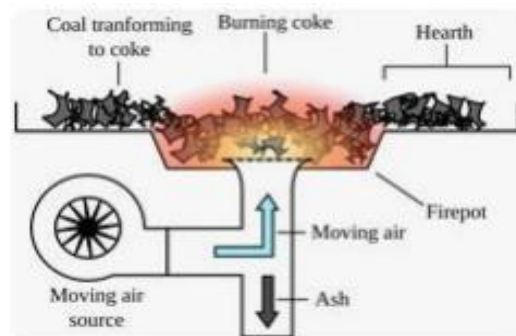

Fig. 2. Partially heated up end of a part to be forged a) and air supplying into forging fire b)

The vertical cross section through the forging fire is given in Fig. 2b). Charcoal was used over milenia but now the coke and or propane/butane gas mixture are more desired for heating up for forging. Water power was introduced into iron production in the XII century, allowing the use of large hammers in forging processes.

Pretty long time the forging process (—drop forging) is provided when hammer (raised and dropped by hand) strikes and deforms the workpiece – it is so called open-die forging. For these operations is needed a well skillful operator. It also valids for forge welding.

PRINCIPLE OF FORGE WELDING

In forge welding the pressure and temperature have play crucial role. By using only a pressure many welding methods were developed, from those the most important are:

- friction welding,
- ultrasound welding,
- explosion welding and
- stir welding.

Today, the pressure welding is applying in producing some of avio- and auto pieces, thanks to the high quality of those technologies. The real problem in forge welding is limited dimensions.

If the forging force is great than is needed the lower temperature for heating up. In past, the temperature of heating up of a piece is determined only by naked eye, as bright yellow or white. Those temperatures are about 0,9Ts, (between 1200-13000C), as approved by contemporary methods of temperature measurement. Scetch of three principal stages during forge welding of an axe is shown in Fig. 3.

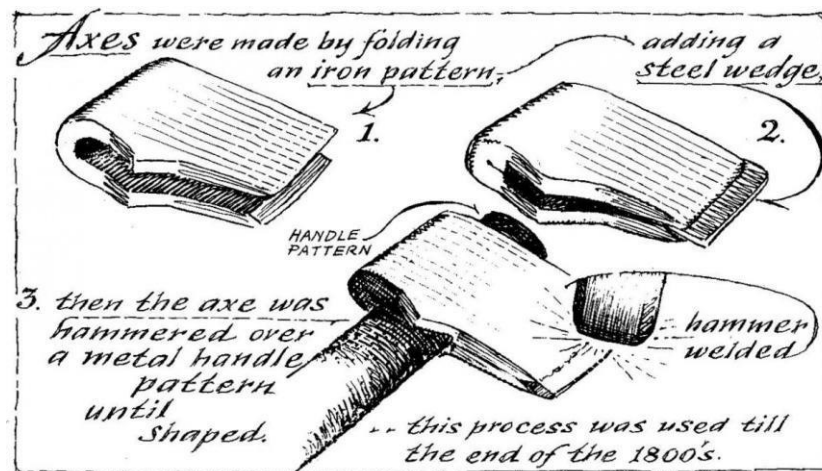

Fig. 3. Principal operations in forge welding of an axe with insert

After the piece, from a moderate carbon steel ($\approx 0,30\%C$), is heated up to desired temperature, next operation is the folding (1) at Fig. 3. The second operation (2) is adding the insert from high carbon steel ($\geq 0,70\%C$), position (2). Then, the juncture is ready to forge (3).

In industrial practice is well known the impossibility of welding when the high carbon steel is used. The critical moment in producing the axe with an insert is the moment of welding, two views are shown in Fig. 4. The forge welding starts when the pieces are heated up near to white color, it means to the pretty high temperature, say about $1300^{\circ}C$, Fig. 4a). Overheating is not allowed, from the metallurgical reasons. After few strikes the pieces are going to cooling down, as could be see from Fig. 4b). In that case, it means that the forging procedure must be stopped and reheating is needed. The number of reheatings is not determined in advance, it depends from the kind of used steels, dimensions of forged parts (here an axe), further from the used energent (fuel), and however from the skillfull of blacksmith.

The process of forge welding must be stopped after pieces are cooled, it could be noticed by changing the color, say at orange color, Fig. 4b).



Fig. 4. Critical moments in hand forge welding: a) beginning (bright color) and b) at the end (pieces were cooled to orange color)

In situation as in Fig. 4b) the reheating of cooled pieces must be provide.

RESULTS AND DISCUSSION

Microstructure of forge welded joint

The microstructural review is one reliable method for observation the state at the weld zone. Many thin cracks in metallic materials could not be registered by ultrasound or gamma-ray techniques, but are available by microscopic monitoring. The presence of eventually imperfections or nonmetallic inclusions will be seen in metallographic view. Microstructures of both materials, low and high carbon steel after forge welding is done, are shown in Fig. 5.

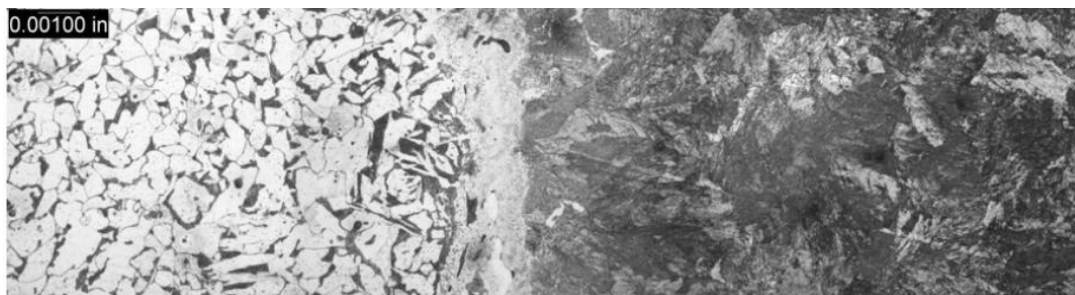

Fig. 5. Microstructures of two steels obtained in forge welding: left – low carbon and right – high carbon steel [11]

The existence of two different materials clearly is visible. The binding zone is homogenous and free of microcracks, those were the aim of welding. After the forge welding is finished, the axe further is heat treated (quenched and tempered) and at the end of processing the edge is sharpened by grinding, sometimes polishing. Picture of some steps in producing an axe is shown in Fig. 6.



Fig. 6. Some steps in hand forging/forge welding of an axe with insert of high carbon steel

Forging and forge welding require really simple tools: hammer, anvil and forge fire, it means without electrical current, plasma, laser, shielding gas/mixture, etc. Forge welding is available by hand strikes, but in last centuries for this purpose are used hydraulic or air hammers.

Forge welding is, however, based on forging technology. The pieces to be joined must be heated up to the higher temperatures than for ordinary forging. For successful forge welding the pieces must be heated up to $0,9T_s$. The strong strikes lowering the temperature. The forge welding must be done by pretty fast strikes, sometimes with two blacksmiths if needed, with synchronized moves. Even though the high temperature is applied; the strong strikes enable obtaining the fine grain structure of deformed metal.

For the body of an axe commonly is used a kind of softer structural steel, about 0,30%C, while for the cutting edge must be used an insert from high carbon tool, steel with more than 0,70%C. The greater content of carbon is needed for achieving the great hardness and strength at the cutting edge after quenching and tempering.

Today, the handy forging is rarely in using, because for its providing are needed both great skillfull and fast moves, so the production periode becomes long. It is clear that many welding methods with using an electric current (on different ways) are faster than handy forging techniques, but the forging usually gives better properties of finished product, also in aesthetic appearance, than mentioned welded products.

CONCLUSION

The axe from the ancient times was an useful tool for man. Pretty early, such man achieved to produce this very qualitative product, even from two different materials/steels. The welding of diversified steels, if one is low and another high carbon steel, represents the problem even today. On the empirical way, the man discovered the production schedule of forging and forge welding, which are approved by contemporary methods of investigations. However, this principle is also available for production of very qualitative goods, as for chains, etc. Handy forging does not require expenses for machinery, tooling and high-temperature furnaces, but the workers must be very skilled.

By inserting a high carbon steel at the cutting edge, in a body of an axe from a low carbon steel, is achieved very good connection between these different materials, as could be seen from metallographic view. The microstructures of this forge weld shows pretty good adhesion of two kinds of steels in the fusion zone.

REFERENCES

- [1] V.N. Volčenko, V.M. Jampolskij, V.A. Vinokurov, i dr: Teorija svaročnih processov, in Russian, Moscow 1988, Visšaja škola, p. 131-138.
- [2] B. Lundqvist: Sandvik Welding Handbook, Sandviken-Sveden 1977, Sandvik, p. 72-97.
- [3] M. Morimoto: The forging of Japanese Katana, Colorado School of Mines, 2004.
- [4] M. Okayasu, H. Sakai, T. Tanaka: Mechanical Properties of Samurai Swords (Carbon Steel) Made using a Traditional Steelmaking Technology (Tatara), J. of Material Sci&Engineering, 4/2015/2.
- [5] M.L. Bernštajn: Struktura deformirovanih metallov, in Russian, Moscow 1977, Metallurgija, p. 247-389.
- [6] I.K. Suvorov: Obrabotka metallov davleniem, in Russian, Moscow 1973, Visšaja škola, p. 353-365.
- [7] V.F. Grabin: Metallovedenie svarki plavljeniem, in Russian, Kiev 1983, Naukova dumka, p. 76-91.
- [8] Ø. Grong: Metallurgical Modelling of Welding, London 1994, The Institute of Materials,
- [9] S. David, J. Vitek: Principles of Weld Solidification and Microstructures, Int. Trends in Welding Science and Technology ASM 1993, p. 147-157.
- [10] G.I. Beljčenko, S.I. Gubenko: Osnovi metallografii i plastičeskoj deformacii stalji, in Russian, Kiev-Donjeck 1987, Višča škola, p. 165-186.
- [11] J. Kellar, S. Howard, M. West, W. Gross, D. Medlin: The samurai sword design project and opportunities for metallurgical programs, South Dakota School of Mines and Technology, 2009.
- [12] A. Tofil, Z. Pater: Overview of the research on toll, forging processes, Advances in Science and Technology, Research Journal, 11/2017/2, str. 72-86.
- [13] G.J. Davies, J.G. Garland: Solidification Structures and Properties of Fusion Welds, Int. International Metallurgical Reviews, 20/1975, str. 83-105.
- [14] 2007 ISO 6520-1, Welding and allied processes — Classification of geometric imperfections in metallic materials — Part 1: Fusion welding.

VOCATIONAL KNOWLEDGE TRANSFER OF CRAFT MASTER SKILLS IN POST-INDUSTRIAL ERA

Vlad Walter Veckie¹, Edward Anthony Veckie¹

¹Unified Engineering Corp., Ontario, Canada

e-mail: veckie@gmail.com

Abstract: Post-industrial era can be described as a time of transition from primarily manufacturing of physical goods to service economy, due to technological revolution conversion in the last decades of the 20th century. This decline from industrial manufacturing has led to higher unemployment and demise of traditional craft skills vocational training. Economies of developed world is confronted with the shortage of the skilled industrial trade, as well in qualified home trade service i.e. cabinetmakers, plumbers and electricians. Shrinking availability of trained crafts people requires implementation of more practical apprenticeship programs, ensuring these skills don't get lost. This paper points out the importance of mentoring in manufacturing, as well as for service companies and presents results of survey on mentoring in three medium-sized companies in Canada.

Key words: craft trades, working with hands, skills knowledge transfer, apprenticeship programs, mentoring

INTRODUCTION

The impetus for the current research, and for this article, came from concerns expressed to the author by entrepreneurs about the apparent trajectory of diminishing availability of craft skill trades. Traditional crafts are still "in the hands of an ageing population" and time is running out to exploit their knowledge and experience. The world is aging and globally population aged over 60 is growing faster than any other generation. Skilled trades retiring is creating workforce gap which affects all manufacturing industries, and gloomily the existing apprentice training is not effectively bringing the young replacement. If this workforce gap is not addressed suitably, it might result in traditional know-how expertise and skills of craftspeople to vanish. According to the World Economic Forum, it points to new future trends where hands-on craft skill work might be less sought after, as the world will turn to new inventions of technology and automation. But at same time, life ergonomics require coordination of mind and movements. This "fame" of scientific and professional prophecy is illusory prediction from fact that human hands with practical work are always a necessity in all activities in life and hands-on professions [1]. Stereotype belief for years now has been that attending the apprentice training in vocational tech schools are young students who couldn't participate in "regular" school. This skilled trade gap in manufacturing requires more assertive education approach in making apprentice qualifications appealing to new generation to participate in "hands-on" crafts training pro-grams. Amalgamation of theoretical learning at school with alternating practical work in industrial manufacturing facilities allows apprentices to develop practical knowledge and skills relevant to the labor market and employer needs. Apprentices through practical "hands-on" work are supervised by their mentors to learn craftsmanship by observation, imitation and practice. Skilled trade training initiatives should be aimed at providing training to teachers and mentors within companies. One of important aspects of skilled trade education in existing manufacturing plants is engagement of mentors, who are recognized by plant management as competent journeymen trained to work and guide apprentices. Another approach in passing on technical expertise and skills is to invite retired journeymen to return to the place of their previous employment and take role of "hand-on" mentoring apprentices. Acceptance of a journeyman to mentor other trade workers can be challenging because beside professional competence requires "soft skills" personal approach. Collaboration between mentor and apprentice can be beneficial, especially as reciprocal form of mentorship, where junior computer savvy employees teach senior journeymen and help them to learn skills to understand computerized information technology.

APPRENTICESHIP

Brief History of Apprenticeship

Back in early history during the 18th century BCE in Egypt and Babylon, the Code of Hammurabi of Babylon rules for master craftsmen ratified how to ensure transfer of knowledge and skills to younger generation to safeguard continuation of quality of their trades. Initially during Roman Empire craftsmen were slaves, but eventually “collegia” associations similar to guilds were established to recognize and control craftsmen reputation. During Middle ages by the 13th century in western Europe craft guilds as trade association were established control the quality, methods of production, training of apprentices and work conditions. A master craftsman retained apprentices in their early teens as a free labor, but provided food, lodging and formal training in the craft [2]. Apprenticeship and trades today are regulated by government educational authorities, trade unions and business organizations. The labor laws support “dual” character of the training system where the vocational part-time schools replace the traditional high schools. This “dual” type of training requires improving and better coordination between the school and the workplace. The new initiatives of involving internal with external mentors in companies can enrich the existing training programs. Continuous training to teachers and mentors at college level and within companies should be implemented by education authorities, by local chambers and augmented through government funding.

Craft Trade Labor Shortage

Manufacturing is dealing with pending shortages of skilled-trade workers. According to EMSI (Economic Modeling Specialists International), age is an important factor in skilled trade shortage. Age break-down comparison between skilled trades and all jobs indicates that skilled trades are retiring earlier and replenishment with younger generation trades in manufacturing is becoming critical.

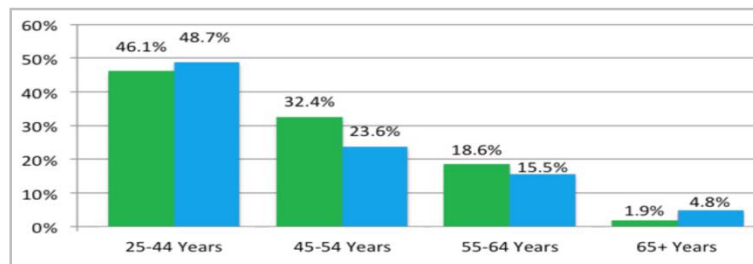

Fig. 1. Age Breakdown: Skilled Trades vs. All Jobs [3]

According to the above breakdown skilled-trade workers keep working after the age of 65-far fewer than in other occupations. One reason is that skilled trades jobs are physically demanding, although, an opportunity should be created for skilled trade seniors to work as mentors upon retirement.

Craft Trade Apprenticeship

Trade apprenticeship benefits the economy, individuals and companies. Collaboration of private sector with public authority benefits companies, apprentices and manufacturing economy. According to Encyclopedia Britannica apprenticeship is *training in an art, trade, or craft under a legal agreement that defines the duration and conditions of the relationship between master and apprentice* [2]. A skilled trade apprentice is trained under supervision of qualified journeyman on the job and also learn in a classroom from instructors who know the trade. In addition, a qualified mentor, who is usually experienced journeyman, can be assigned to an apprenticeship to lead him or her in acquiring work habits and trade skills. Phases of skilled trade training are outlined in three various stages of development: from apprentice to journeyman and to the final recognition as a master. Each segment of training and skills development is based on professional competence and technical knowledge as described in table 1.

Table 1. Phases of Skilled Trade Training

Apprentice	Journeyman	Master
In-process of Improving Technical Expertise (Learning elementary trade skills)	Competent Technical Expertise (Proves ability to complete tasks working as a team, but recognizing his/her own trade skills limitations)	Mastered Technical Expertise (reached recognition by authorities and other masters to share expertise as a mentor and instructor)
Primary Professional Competencies (Works under supervised instruction to correct and improve on making mistakes)	Ability to complete tasks with Professional Competencies (reached professional growth to teach, mentor and supervise others)	Demonstrates Professional Competence (co-operates and interacts with other masters to develop technical applications and leads others to improve performance)

Source: [4]

Apprenticeship training has similarities with Canadian, German or Swiss programs in collaboration of companies, educational institutions and government that is known as Triple Helix model in economic development. In order to participate in apprenticeship training programs, companies have to be assessed to prove the existence of appropriate trade manufacturing facility and employs qualified in-company trainers and mentors. Business training plan has to be prepared and approved to gain approval for government funding under Department of Labor umbrella. There is cost in hiring and training apprentices, for which is usually assistance available in the form of government grants and incentives for companies taking on apprentices [5]. Journeyman mentor, besides being proficient in trade, must have ability to teach and transfer knowledge to an apprentice. Approval of a journeyman to become a mentor to other trade workers can be challenging, because beside professional competence requires “soft skills” in personal approach toward apprentices. These “soft skills” are also important to throughout progression path of apprentice-journeyman-master in learning to higher level of competences and ultimately expand on effective networking with professional acquaintances. This network of passionate trade associates can later in life create a cluster of entrepreneurs to join together in business cooperatives. In-company apprenticeship training differs worldwide based on, governance, employer cost-sharing, recruitment procedures and support structures to maintain the right balance in all stakeholders’ interest. Most countries share costs of apprenticeships programs between government incentives, employers, trade associations and unions. In some countries apprentices are hired as regular employees or are employed as part time students. Principal difference relates to contractual agreement where companies treat apprentice training as an investment with their commitment to stay on working for certain period of time upon graduation. It is important to for companies to participate in apprenticeships programs as an effective means of recruitment, which eventually produce a pool of skilled trade journeymen and allows market sharing of trained resources. This pool of trade skill graduates stream is in the interest of manufacturing economy and nourishing labor market.

Enticement for manufacturers to be involved in apprenticeship programs

Manufacturers empowering employees is important element of company sustainability and reputation. Investment in building competence of employees in training and apprenticeships benefits the economy, individuals and companies.

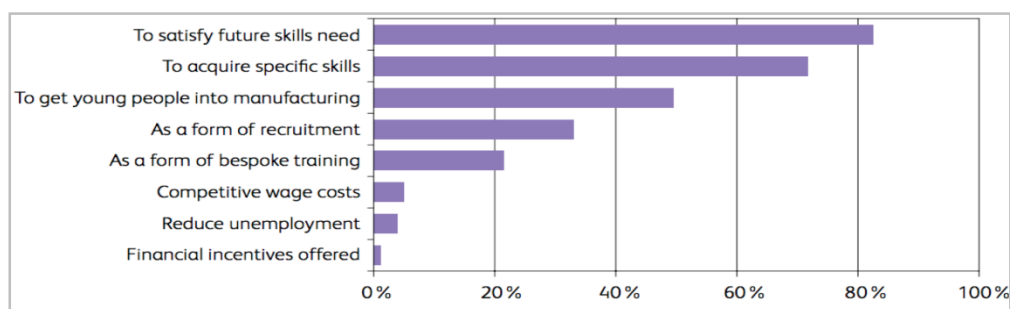

Fig. 2. Reason why manufacturers offer apprenticeship [6]

As an add-on to the above chart there are other motives for manufacturing companies' decision to be involved in apprenticeships:

- An important reason for companies to engage in training is to secure a skilled workforce in future.
- Technological improvement in manufacturing sector forces companies to invest in latest equipment and apprentices are exposed to the most advanced state of the art technology. In comparison school training facilities mostly operate with existing equipment.
- The advantage of Dual System apprenticeship at school improves knowledge of science, technology, and mathematics.
- Apprentice time of learning at school expands IT-related skills and competences.

Education Endowment Foundation (EEF) reports lack of qualified skilled trades and advocates the government to launch new programs for apprenticeships and reform the education system to fill the gap of trade people leaving for retirement [7].

Trades Apprenticeship Ending Note

In conclusions, the performance of a successful apprenticeship program depends on key elements, such as type of dual apprenticeship system, teachers, in-company trainers or mentors, approved training facilities, governance, stakeholder's cost-sharing, legal contract arrangements and recruitment procedures. The right balance between these elements and the diversity of education programs require adjustment according to labor market situations. Another challenge is to change the skewed perception of the trades as an inferior type of vocation and recognize trades an attractive profession [8].

THE ROLE OF LEADERS & MENTORS IN APPRENTICESHIP TRAINING

Leaders & mentors have important role in economic development while working, as well as when continuing mentoring as volunteers during active retirement. Correlation of mentors in skilled trade training programs emphasizes the importance of a relationship between mentor and protégé and explores developments of mentoring models. Successful mentoring is a relationship between mentor and protégé where both partners accomplish mutual correlational benefits.

Brief History of Mentorship

The conception of mentoring originated in ancient Greece, when Odysseus entrusted his friend Mentor to teach and protect his son Telemachus [9]. Since then mentoring models have evolved to have a significant impact on knowledge transfer and professional development. The evolution of economy from feudalism into industrialization changed ways of communication and accelerated knowledge transfer. The new wave of information revolution known as Computer or Digital Age is as important as Gutenberg's invention of mechanical movable type printing press in the fifteenth century. IT technology is making an impact on all generations. The latest era of computerization has revolutionized sharing of knowledge through instant retrieval of information and evolution of mass media communication. Millennials embraced computers and it opened new opportunities for the techno-logically savvy younger generation to advance through hierarchal organizational structure.

Reverse mentoring emerged as an open-minded mentoring model, where IT competent younger generation leaders contribute to relationship through reversed mentoring of older generation executives. The further advancement through natural development of mentoring relationship is a transition from a reverse model into a reciprocal one. Intergenerational knowledge transfer supports entrepreneurial strive to improve employee retention, excel in innovations and competitiveness, therefore increase enterprise's market share, and contribute to the accelerated economic growth.

Development of reciprocal mentoring as a collaborative model

Recognition of mentoring is on the rise since the late 1980s. Importance of mentoring excelled since Kram's influential work [10] [11]. Mentoring relationships are recognized as one of the most effective way of transferring knowledge and experience in inspiring development of new leaders and *opportunity*

to interact one-on one with members of senior management helps newer employees develop a more sophisticated and strategic perspective on the organization [1]. Theoretical research about positive benefits of mentoring has been researched in books, journal articles and research papers [12]. Traditional hierarchical mentoring model encompasses accomplished leaders as mentors to junior level employees. Rapid technological advances and generational diversity is transforming typical employee relationships. Reverse type mentoring is another model, where junior computer savvy employees mentor their senior managers and help them to learn skills to understand compute-rized information technology. This direct exposure of lower level employees to senior leaders led to reciprocal mentoring model as a two-way relationship for the benefits of both sides, especially beneficial to juniors in better understanding of the business operation [2]. Continuous extensive research created major advances in developing new mentoring models, which are implemented in entrepreneurial organizations and education institutions. Research papers, journal articles and books discuss positive benefits of mentoring [3]. In traditional hierarchical mentoring model accomplished leaders are mentors to junior level employees. This one-way mentoring model is mostly beneficial to protégé [13]. The reciprocal model of mentoring progressed from reverse model and it has been recognized in research literature on development of knowledge transfer; *mentoring has a dual focus on the leadership development of both mentor and mentee. Millennial mentors have the opportunity to demonstrate capabilities as leaders through their coordination of tasks and goals in this relationship.* [14] Rapid technological advances and generational diversity are transforming typical employee relationships. Developmental relationships are becoming one of the most important tools in cultivate new leaders [15]. Today multiple generations from aging boomers to young millennial are working side-by-side. Senior managers and aging mentors are challenged to become acquainted with new IT computerized technology. Computer savvy younger employees and senior management have mutual interest in learning from each other through reciprocal model of collaboration of knowledge exchange. Reciprocal mentoring is a two-way mutually beneficial correlation and gives opportunity to both participants to share knowledge and improve their competency [16].

Mentorship in Craft Trades

Mentorship take important role in entrepreneurial learning, as well as in the context of trade skills multigenerational knowledge transfer in craft trades. In order to explore mentorship development this paper compares different mentoring models and how reciprocal model changes correlation benefits for an apprentice and senior mentor in craft skills training programs. Theoretical overview of two-way reciprocal mentoring relationship and correlation benefit findings in this paper confirm the hypotheses of positive overall effects on employees and to the overall prosperity of the company. Multigene-rational knowledge transfer models have variations in manufacturing, other industrial enterprises, government, academia and education.

Data collection, measuring and analysis

Scientific contribution of this research presents alternative correlation benefit analysis of cross-generational mentor/protégé model in reciprocal mentoring, as well as attitudes following completion of mentoring programs. Three distinct different companies are analyzed to explore conceptual understanding of entrepreneurial learning through mentoring process. The research has evolved from my own experience as an entrepreneur and as an executive being involved in managing and developing new engineering and craft skills talents for SME companies in Canada. The research survey emphasis value of reciprocal mentoring model and which are benefits to individuals and organization. Case studies in this research indicate that reciprocal mentorship is naturally occurring in small and medium size companies, as in large companies is engineered and is part of human resources training policy. Research in this paper corroborate evidence that reciprocal mentoring model brings further correlation benefits to individuals, improves employee retention, as well as enhanced performance of the entire organization. The findings in this research should encourage executives, entrepreneurs and human resources managers to implement reciprocal mentoring model and conceptualize it as an important initiative. The research framework developed is based on observations, narrative exchange, interviews and qualitative methodology with corroborative analysis of data collected. Data used for employee retention is sourced

from available human resource records for each company. The paper research studied employee satisfaction feedback on how reciprocal mentoring changed attitudes, level of competence, change of inner-company communication and variations in level of employee retention. Therefore, to analyze qualitative results, it was the most practical to use semi-structured confidential narrative exchange and voluntary interviews based on pre-determined set of open questions. Reciprocal mentoring satisfaction questionnaire results are expressed in percentage of positive or negative change, such as: (a) employee relationship, (b) multi-generational collaboration, (c) employee attitudes, (d) supervisor/subordinate collaboration performance, (e) job satisfaction, (f) company meeting expectations, (g) employee retention (2 categories), (h) enhancement leadership skills, and (i) - motivation to continue further education and training. Employee retention is one of the indicators of employee job satisfaction and survey questionnaire distinguishes two types of possible answers that suggest employee commitment to stay with a company. An employee has a choice to choose one of the answers. The first choice of answer is whether employee is currently searching for another employment elsewhere or employee is committed to stay with company.

Measuring Employee Retention Rate

Employee retention rate indicates employee fluctuation and capacity of an organization to retain its employees. Employee retention rate can be calculated as follows: Total number of employees in the company number of employees minus number of employees who left the company divided by total number of employee and express as a percentage [15].

$$\text{Retention Rate \%} = \frac{(\text{Total number of employees} - \text{Employees that left})}{\text{Total number of employees}} \times 100$$

Retention rate number is the company personnel stability indicator and is usually calculated for a period of one year. This number does not include fluctuation of number of employees that left and joined company within the same time period. Turnover rate can influence and compliment retention rate and is calculated by number of employees left divided by the average number of company employees during the same time period [17].

Employee participant's survey

The size of three firms has analyzed in this paper employ approximately 30 to 40 employees.

- Company #1 - is specialized in consulting engineering and fabrication.
- Company #2 - is in precision machining/manufacturing.
- Company #3 - is specialized in heating and ventilation equipment installation and service.

In the field of demography generations in the study are defined by the year of birth and are further divided in two groups based on work job category and management position.

1) Age/Work Experience Groups: (a) Traditional Mentors Group born 1946 -1976 and (b) Digitally Savvy Junior Mentors Group - born 1977- 2000

In the field of job category employees are classified in three groups:

2) Job Classification Groups: (a) Manager/Engineer, (b) Skill Trade Employee, (c) Apprentice

Questionnaire form for participants of the reciprocal mentoring program is created based on description of Employee Participants Survey. Results of survey are compiled in Table 2 - 4.

Table 2. Comparison Employee Retention Rate

Employee Retention Rate	Company 1	Company 2	Company 3
Before Reciprocal Mentoring Program	40%	50%	57%
After Six Months of Program implementation	55%	59%	56%

* Employees were expected to mark response on a 5-point scale where 1 is completely unsatisfied and 5 is very satisfied.

** The scores are calculated as average, based on replies of employees of all three companies analyzed.

*** Changes in Retention Rate comparison is calculated before implementation and after of six months of the program.

The data collected before and after the reciprocal mentoring program for each job classification is entered into tables and charts below. The results show positive significance of reciprocal mentoring implementation. Older apprentices born from 1946 to 1976 have been rehired through government program of requalification of people whose work place became redundant. All three companies have implemented apprentice program for training and requalification of older employees, who were forced to change their vocation for a new job. In Table 3 the score comparison is recorded before implementation of mentoring program and after completion of program. The answers in employee survey rating show consistent improvement in all areas, except in answers to question for managers/engineers about opportunity for career advancement and also for skilled trade motivation to pursue education and training. The rating of the opportunity to career change for managers/engineers stayed the same and explanation might be that older employees did not feel motivated to change or advance in their career. An explanation for lack of motivation to continue further training for older age skilled trade was that their qualification reached the top. The most positive attitude changes have been recorded for managers/engineers feeling that company achieves their expectation and also that leadership skills improved following the mentoring program. The most positive attitude improvement for skilled trades has been recorded in supervisor/ subordinate collaboration, as well as improvement in leadership skills. In Tables 3 score comparison is recorded before implementation of mentoring program and after completion of program. The most positive attitude changes have been recorded for managers/engineers in supervisor/subordinate collaboration, improvement in leadership skills, motivation to pursue further education and recognition that overall work environment improved. Skilled trades indicated the most improvements in multi-generational collaboration, job satisfaction, desire to pursue further training, opportunity for career advancement and overall recognition that company achieved their expectation. Following mentoring program apprentices show most of attitude improvement in supervisor/subordinate collaboration and desire to continue further education and training. In Table 5 the average success score of the mentoring program for all participants is recorded before implementation and after completion of the program. The average success rating show consistent improvement in all areas of employee attitudes - Graphs 3, Graph 4 and Graph 5.

Graph 3



Graph 4



Graph 5



(Source: Author research results for three companies)

Table 3. Data collected for 'A' participant (ages born from 1946 to 1976) and 'B' (born 1946 to 1976)

'A' = Age: born 1946 to 1976 'B' = Age: born 1977 to 2000		Average Scores											
		Before		After		Before		After		Before		After	
		A	B	A	B	A	B	A	B	A	B	A	B
Questions													
1	Team morale	4	4.1	4.3	4.3	3.5	3.2	3.7	3.7	3.7	3.5	3.8	3.7
2	Multi-generational collaboration	3	3.1	4	4.1	3.7	3.3	3.9	3.6	3.8	3.7	3.9	3.9
3	Supervisor/Subordinate collaboration	3.5	3.6	4	3.9	3.2	3.6	3.9	3.7	3.5	3.3	3.7	3.7
4	Job satisfaction	3.9	3.7	4.2	3.9	3.9	3.3	4.1	3.9	4.1	4	4.3	4.3
5	The company achieves my expectations	3	2.9	3.7	3	2.9	2.5	3.1	2.9	3.1	2.6	3.2	2.9
6	Opportunity for career advancement	4	3	4	3.1	2.5	2.6	2.6	2.9	2.5	2.6	2.6	2.7
7	I am committed to stay with the company	4	2.5	4.2	2.8	3.1	3.5	3.4	3.7	4.5	3.9	4.6	4.1
8	My level of leadership skills	4	2.5	4.7	2.9	3.3	2.5	4	2.7	3.5	2	3.7	2.2

‘A’ = Age: born 1946 to 1976 ‘B’ = Age: born 1977 to 2000		Average Scores											
		Before		After		Before		After		Before		After	
		A	B	A	B	A	B	A	B	A	B	A	B
9	I am motivated to additional training	3	3.5	3.2	4.1	4	3.3	4	3.7	4.6	4	4.6	4.5
10	Overall work environment	4	3.9	4.1	4.3	3.6	3.3	3.8	3.5	3.9	3.7	4	3.9

Source: Author research results for three companies

* Employees were expected to mark their response on a 5-point scale where 1 is completely unsatisfied and 5 is very satisfied. ** The scores are calculated as average, based on replies of employees of all three companies analyzed.

Table 4. Average reciprocal mentoring survey success results for all participants

Age	Manager/Engineer			Skills Trade			Apprentice		
	Before	After	Average	Before	After	Average	Before	After	Average
Born 1946 to 1976	3.24	4.04	3.62	3.37	3.72	3.55	3.71	3.84	3.76
Born 1977 to 2000	3.64	4.04	3.84	3.37	3.62	3.49	3.35	3.38	3.37

Source: Author research results for three companies

Mentorship Ending Note

Most research articles with this topic are in field of academic education and virtual knowledge exchange. Theoretical research overview of multigenerational interactions in two-way reciprocal mentoring model is found to be relatively scarce in corporate environment. Reciprocal mentoring implementation in corporate multigenerational environment is presented in this paper as alternative to traditional mentoring models. Contribution of this paper is to validate importance of corporate program in reciprocal mentoring. In this article, as well as other research papers confirm that reciprocal mentoring model is an improvement to conventional models, promotes closer co-operation between employees and creates collaborative benefits to both mentor and protégé. The paper contains brief review of literature in areas of mentoring and entrepreneurial learning. One of benefits of reciprocal mentoring is increase in company innovation capability, as stated in study conducted by Lin [18]. Research papers about mentoring explored reciprocal relationship changes from face-to-face context to online knowledge exchange. *This opens up many possibilities for the development of collaborative reciprocal mentorships on an international scale* [19]. *Global managers engage in reciprocal learning processes to obtain new, innovative knowledge about other countries' environments and business practices* [20]. Recently a new research defined wider application of reciprocal mentoring, as omnidirectional relationship. *In many ways, suggesting that mentoring relationships can be reciprocal relationships where all parties have equal knowledge and expertise to gain and share* [21] Thematic discourse analysis in this paper *Correlation Benefits in Mentoring Relationship* is used to examine mentoring of three entrepreneurial companies in industrial service field. Material in study measures success of learning experiences and is used to develop a conceptual model of mentoring performance analysis and measure accomplishments in employee relationship. Findings based on data analysis have shown that participation of professionals, skilled trades and different ages have positive correlation influence on outcome of formal reciprocal mentoring programs. Attitude of older group of employees show minor or no improvement following complete-ends of formal mentoring program. In general, the findings confirm hypotheses that formal reciprocal mentoring program can be mutually beneficial to all involved and have positive overall correlation effects in employee attitude and company prosperity. Scientific theoretical research of multi-generational knowledge transfer models and overview of reciprocal mentoring suggests how important is to continue further development of the model.

CONCLUSION

Manufacturing economy is facing serious challenges with diminishing skilled labor force due to retiring, industrial plants being moved offshore and critical shortage of trade skill graduates creating craft skills workforce gap. Retiring senior journeymen capable and qualified in knowledge transfer of traditional crafts skills should be reactivated to mentor and train apprentices. According to the World Economic Forum, it points to the new future trends in where hands-on craft skill work might be less sought after,

because the world will turn to new inventions of technology and automation. But at the same time, the life ergonomics require movement coordination between mind and body and must not be neglected. This "fame" of scientific and professional prophecy is illusory prediction from the fact that human hands with practical work are always a necessity in all activities in life and especially in hands-on professions. A greater emphasis on apprenticeship training programs is required with promotion of trades an attractive profession, not an inferior type of vocation. Working with hands and making tangible products is a professional quality to be respected and craft skills will always be required and especially stay in demand for industrial services and maintenance.

REFERENCES

- [1] The Future of Jobs Employment, Skills and Workforce Strategy for the Fourth Industrial Revolution, The World Economic Forum Report, 2016.
- [2] Apprenticeship Encyclopedia Britannica
- [3] Labor Shortages Loom as Most-In-Demand Group of Workers Retire, Career Profiles, 2020.
- [4] Farrell, P., Traversing Your Career Path: Apprentice, Journeyman, or Master IRMI Risk Management and Insurance Research
- [5] Apprentice Alliances EU - Apprenticeships-for-SMEs Report (2017) Report Apprentice, 2017.
- [6] EEF Survey
- [7] Allen, K., Most UK manufacturers are struggling to recruit skilled workers – report, Education Endowment Foundation, 2016.
- [8] Millennials (Still) Don't Want the Trades. Here's why & What Needs to Happen our culture's skewed perception of the trades. Costa A. et al. (2016) The Cost-Effectiveness of Apprenticeship Schemes, Innovation Report Pintsuk-Christof J. et al. (2019) Training Needs of SMEs in the Skilled Crafts and Trades Regarding Dual Education
<https://www.alpine-space.eu/projects/dualplus/pdfs/results/dt22-sme-needs-assessment-report.pdf>
- [9] <https://www.greekmythology.com/Myths/Mortals/mentor.html>
- [10] Mentoring processes at work: Developmental relationships in managerial careers. Kram, Kathy E., Dissertation Abstracts International, Vol 41(5-B), Nov 1980, 1960-1961.
- [11] Dougherty, T.W., Dreher, G.F., - Mentoring and Career Outcomes: Conceptual and Methodological Issues in an Emerging, in Handbook of Mentoring at Work, 51-94, SAGE Publications
- [12] Cotugna & Vickery - Positive Relationships: Evidence Based Practice across the World, 2005.
- [13] Ballantyne, Green, Yarrow & Millwater, 1999; Clarke, 2004; Kochan & Trimble, 2000; Mullen, 2000, Reciprocal mentoring "in the wild":
http://dlconnect.usu.edu/Robertshaw_etal_RM_TPCK.pdf
- [14] https://www.uky.edu/Centers/iwin/RTOCT12/Murphy_Reverse%20Mentoring_HRM21489.pdf
- [15] <https://www.customerthermometer.com/employee-retention/>
- [16] http://hrcouncil.ca/documents/LMI_satisfaction_retention.pdf
- [17] Statistics Canada Shifting demographics, 2015.
- [18] Lin, H.F., Knowledge sharing and firm innovation capability: an empirical study. International Journal of Manpower, 28(3/4), 315-332, 2007.
- [19] Martha A. G.; Kandra J. K. Reciprocal mentorship: an effective support for online instructors, Journal Mentoring & Tutoring: Partnership in Learning Vol. 16, No. 3, pp 311–327, 2008.
- [20] Moeller, M.; Maley, J.; Harvey, M.; Dabic, M., People management and innovation in emerging market multinationals: A competency-based framework, Journal of Management Development, Vol. 35 Issue: 4, pp.530-548, doi: 10.1108/JMD-04-2015-0053, 2016.
- [21] McGowan - Redefining Mentorship as a Reciprocal Process of Teaching and Learning p. 2 in Clapp E. P. - Omni-directional Mentorship:", Harvard Graduate School of Education, 2001.

USING THE LASER SCANNING FOR CONSERVATION OF CULTURAL HERITAGE BUILDINGS

Clara-Beatrice Vilceanu¹, Luisa Dungan², Sorin Herban¹, Francisc Popescu²

¹University Politehnica Timișoara, Faculty of Civil Engineering, Department of Overland
Communication Ways and Cadastral Survey, Timișoara, România,

²University Politehnica Timișoara, Faculty of Mechanical Engineering, Department of
Mechanical Machines, Equipment and Transportation, Timișoara, România

e-mail: beatrice.vilceanu@upt.ro, luisa.dungan@upt.ro, sorin.herban@upt.ro,
francisc.popescu@upt.ro

Abstract: This work is part of the INTEREG IPA CBC Romania Serbia project entitled RORS394 Know to Develop – Through knowledge to business and smart development of Banat. The project's objective was to increase employment opportunities and employability of young people through the creation of organizational and institutional conditions for cross-border and networked improvement of education, knowledge and skills that will meet the needs of the economy and labour market. One of the modules of the project refers to 3D scanning as a high-resolution and accurate recording of the objects in 3D space is of high importance for many subjects of different domains of interest such as monitoring landslides, archaeology, cultural heritage etc. Traditional techniques for 3D data acquisition either restrict the size of the scanned objects or impose demands on the stability and structure of the surface.

On the other hand, various society fields demand realistic 3D city models. For urban planning or historical buildings even ancient fortresses, analysing in a 3D virtual reality world is much more efficient than imaging the 2D information on maps. For public security, accurate 3D building models are indispensable to make strategies during emergency situations. Navigation systems and virtual tourism also benefit from realistic city models. Manual creation of city models is undoubtedly a rather slow and expensive procedure, because of the enormous number of buildings and complexity of building shapes. The rapid development of cities also adds to the cost of manual city model updating. Nowadays, a lot of research has been done to automate the procedure of city reconstruction, and a number of approaches have been proposed. These approaches differ with respect to input data, automation level, and object representation. In this context terrestrial 3D imaging laser scanning forms a method to acquire a large number of precise data points in 3D space representing the surface of the objects under investigation. These scanners are an effective tool for the collection of data to create a digital elevation model of the topography of a site as well as of the surface of a single archaeological deposit.

The acquired data can be used for documentation purposes only, but the further processing provides the possibility for virtual reality modelling for public presentation, restoration planning or virtual reconstruction. Laser scanning technology and the final deliverable, materialized as the three dimensional model of the terrain, emphasises the importance and the applicability of geodesy in giving proactive solutions to architectural and engineering problems.

Key words: laser scan, 3D modelling, digital reconstruction, cross-border project.

INTRODUCTION

The RORS 394 project [1] aims at creating joint cross-border institutions for the promotion and maintenance of knowledge, and joint services of providing knowledge, primarily in the field of IT, as well as a rapidly growing industry, which contributes significantly to technological and sustainable inclusive development of the region. Raising the quality of education makes young people more employable; the collaboration between industry and institutions contributes to the adaptation of knowledge to the needs, and the existence of the place for informal education is an opportunity for these practice needs to be quickly transformed into knowledge. Lifelong education through training of the trainers and online courses in the IT, entrepreneurship and management, contribute to the preservation and enhancement of the quality of knowledge which is a prerequisite for the sustainable inclusive growth, the growth based on the involvement and improving of knowledge of the local and regional participants.

In this context, different training sessions have been realized in Timisoara as follows: training in CNC programming (22-24.11.2019), training in Entrepreneurship (06-08.12.2019) and training in 3D scanning and printing (17-19.01.2020).



Fig. 1. Photos from the training sessions realized in Timisoara

Three-dimensional data capture of objects on the Earth's surface is an important aspect of surveying and mapping, geospatial database construction, and 3D digital visualization. Currently, digital data acquisition is largely applied to 2D spatial databases. In this study, we present a new method that applies ground based laser scan survey and 3D digital building model construction. Previously, ground survey of spatial objects was mainly accomplished by a surveying total station. The method is relatively labour intensive and requires data conversions from analogue to digital to incorporate the results into a geospatial database [2].

3D scan data is useful in archaeology, paleontology and cultural heritage applications for dimensional analysis and study, providing a digital archival record, increased access to objects in remote locations, and to produce replicas useful for public exhibits. There is no way to record a complex object than with a high resolution 3D scan. The fringe projection method used in white light scanning allows non-contact digitization of art and sculpture and historical artefacts. Direct comparisons can be made of dimension and shape. Scanning allows revisitation of any object over time, including redrawing of cross sections, 3D volume calculations, and other analysis that would otherwise prove to be very difficult if not impossible [3].

Traditionally, archaeological or architectural information is published in a monograph or book. But this kind of documentation cannot (or is more difficult to) be distributed economically and does not adequately depict the complex visual and technical data needed for study [4].

Vectorization is the process of making explicit, information in the raster image, by defining objects within the image using lines, arcs, closed polygons etc [5]. Vectorization of contours from a scanned topographical map is a complex procedure, requiring identification of features, rigorous image classification strategies and manipulation of spatial data structures like direction of line, boundaries and nodes, polygon vertices chain etc. the automatic extraction of contour lines from a scanned topographical map and its subsequent vectorization is one of the major research problems in computer cartography and GIS.

MATERIAL AND METHODS

Mathematic method

In order to obtain 3D coordinates, we have to transform the coordinates from one system to another and there must be a connection between ellipsoids' origins and axes. From this information, the system origin translation in space X, Y, Z axis followed by rotation around X, Y, Z axis and the scale factor between the two ellipsoids can be determined. We denote the position vector of a point in space from the reference coordinate system XLOC and position vector of the same point in the secondary coordinate system with XGPS. Conform three dimensional transformation is described by the relation:

$$X^{LOC} = X_0 + mRX^{GPS} \quad (1)$$

I denoted with "m" the scale factor, with X_0 translation vector between the origins of the two systems, and the "R" rotation matrix which consists of three successive rotations around the coordinate reference system axes. With the rotation angles $\alpha_x, \alpha_y, \alpha_z$ the rotation matrix has general form:

$$R = \begin{pmatrix} \cos\alpha_x \cos\alpha_z & \cos\alpha_x \sin\alpha_z + \sin\alpha_x \sin\alpha_y \cos\alpha_z & \sin\alpha_x \sin\alpha_z - \cos\alpha_x \sin\alpha_y \cos\alpha_z \\ -\cos\alpha_x \sin\alpha_z & \cos\alpha_x \cos\alpha_z - \sin\alpha_x \sin\alpha_y \sin\alpha_z & \sin\alpha_x \cos\alpha_z + \cos\alpha_x \sin\alpha_y \sin\alpha_z \\ \sin\alpha_x & -\sin\alpha_x \cos\alpha_y & \cos\alpha_x \cos\alpha_y \end{pmatrix} \quad (2)$$

In order to solve the system, equation (1) must be linearized temporary values being needed for the unknown parameters. In the case of geocentric coordinate transformation into a national system of coordinates, there are some simplifications and the rotation matrix (2) becomes:

$$R = \begin{pmatrix} 1 & \varepsilon_z & -\varepsilon_y \\ -\varepsilon_z & 1 & \varepsilon_x \\ \varepsilon_y & -\varepsilon_x & 1 \end{pmatrix} = I + dR \quad (3)$$

Where: $\varepsilon_x, \varepsilon_y, \varepsilon_z$ – the rotation angles differential sizes; I - unit matrix; dR - differential matrix.

Also, instead the vector containing the origin translations of the two systems, $X_0 = (X_0) + dX_0$ can be introduced, and (X_0) after the provisional values introduction for a single point "m₀ = 1" and "R₀ = I" becomes: $(X_0) = XLOC + XGPS$. All this will be introduced in equation (1) resulting the relation:

$$X^{LOC} = (X_0) + dX_0 + (1 + dm)(I + dR)X^{GPS} \quad (4)$$

The Expression: $dX_0 + dm X^{GPS} + dR X^{GPS}$ – can be represented as a configuration matrix, A, which is multiplied by the unknowns' vector, which contains the dx transformation parameters, thus the equation becoming:

$$X^{LOC} = Adx + X^{GPS} + (X_0) \quad (5)$$

If there is no information regarding the terms size from provisional values vector for the translations (X_0) , a zero size can be accepted and it results:

$$\begin{pmatrix} \Delta X_1 \\ \Delta Y_1 \\ \Delta Z_1 \\ \dots \\ \Delta X_m \\ \Delta Y_m \\ \Delta Z_m \end{pmatrix} = \begin{pmatrix} \Delta X_1^{LOC} - \Delta X_1^{GPS} \\ \Delta Y_1^{LOC} - \Delta Y_1^{GPS} \\ \Delta Z_1^{LOC} - \Delta Z_1^{GPS} \\ \dots \\ \Delta X_m^{LOC} - \Delta X_m^{GPS} \\ \Delta Y_m^{LOC} - \Delta Y_m^{GPS} \\ \Delta Z_m^{LOC} - \Delta Z_m^{GPS} \end{pmatrix} = \begin{pmatrix} 100.X_1.0 - Z_1.Y_1 \\ 010.Y_1.Z_1.0 - X_1 \\ 001.Z_1.-Y_1.X_1.0 \\ \dots \\ 100.X_m.0 - Z_m.Y_m \\ 010.Y_m.Z_m.0 - X_m \\ 001.Z_m.-Y_m.X_m.0 \end{pmatrix} * \begin{pmatrix} X_0 \\ Y_0 \\ Z_0 \\ m \\ \varepsilon_x \\ \varepsilon_y \\ \varepsilon_z \end{pmatrix} \quad (6)$$

with: $m \geq 3$, common points.

The system solving (6) leads to the seven unknown parameters determination $X_0, Y_0, Z_0, m, \varepsilon_X, \varepsilon_Y, \varepsilon_Z$. New points coordinate transformation determined only from satellite measurements will be now based on the seven parameters $\rightarrow X_0, Y_0, Z_0$ (three translations), m (scale factor) $\varepsilon_X, \varepsilon_Y, \varepsilon_Z$ (three rotations) with the transcendental relationship from relation (1) [6].

RESULTS AND DISCUSSION

The case study refers to a residential building situated on 1 Decembrie 1918 Street, Timisoara municipality, an old building considered a historic monument. This building is located in a very frequented area by the citizens, being located near Balcescu Square and near "Grigore Moisil" theoretical high school. For this building, the terrestrial scanning operation (Fig. 2) was performed both before and after its rehabilitation.

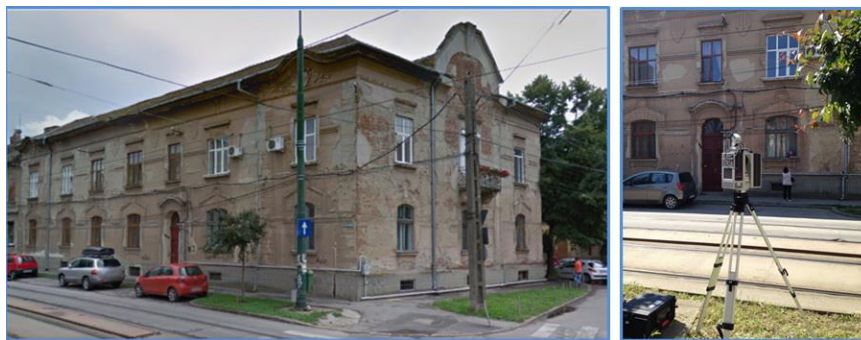

Fig. 2. Historical building under study and laser scanner station's location

The scanning session lasted approximately 30 minutes, around 6 minutes for each scanning station. Data collected on field was stored on one of the two external hard-disks in order to be further processed at the office. Several stages of the 3D modelling process are highlighted:

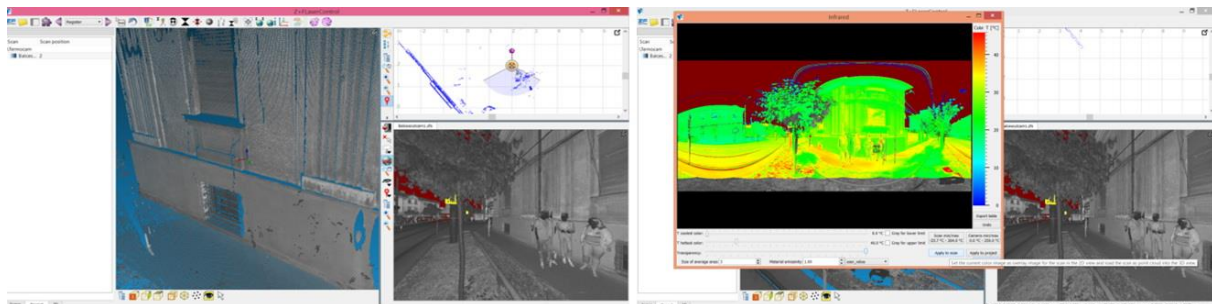

Fig. 3. 3D View, Image space and station's sketch (left image) Temperature filters (right image)

The angle that the plane of the target with the laser beam should be neither not too obtuse or too sharp, ideally 90o, but this is almost impossible for all targets. If registration quality is needed, the .png files are saved directly into the ".target" folder by the program.

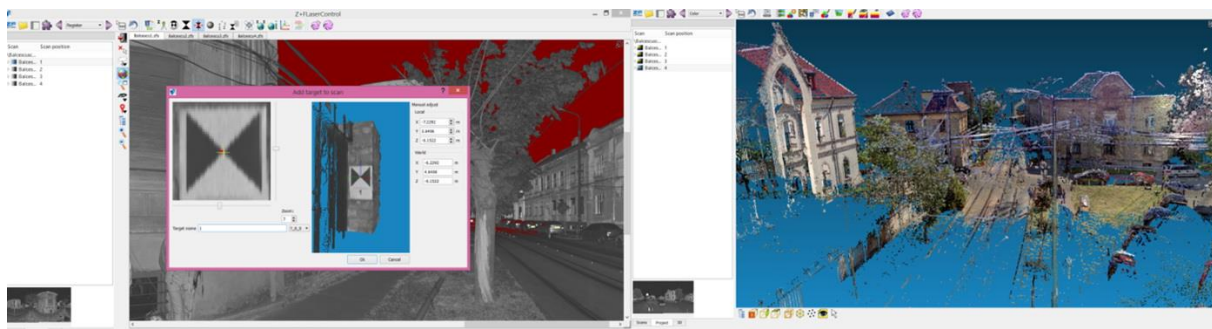

Fig. 4. Manual registration of the targets (left image) Coloured point clouds (right image)

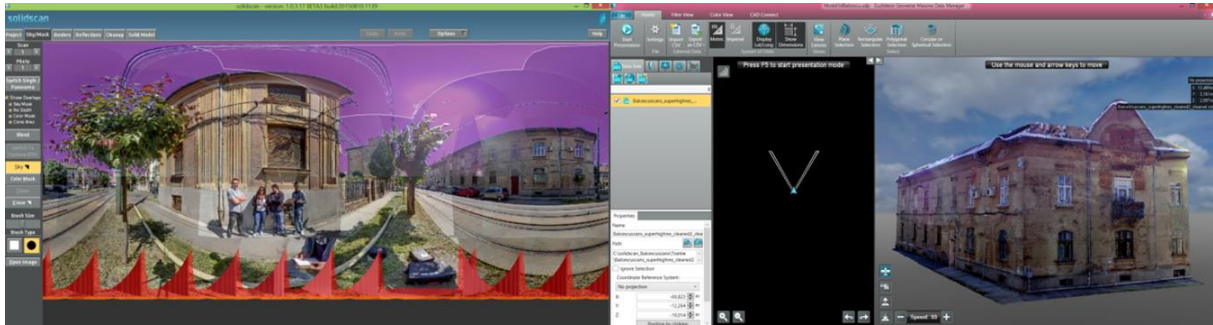

Fig. 5. Reducing the noise – cleaning the point clouds (left image) Final 3D model (right image)

In order to realize a complete digital documentation, the cultural heritage building was also scanned after the rehabilitation works have been effected.

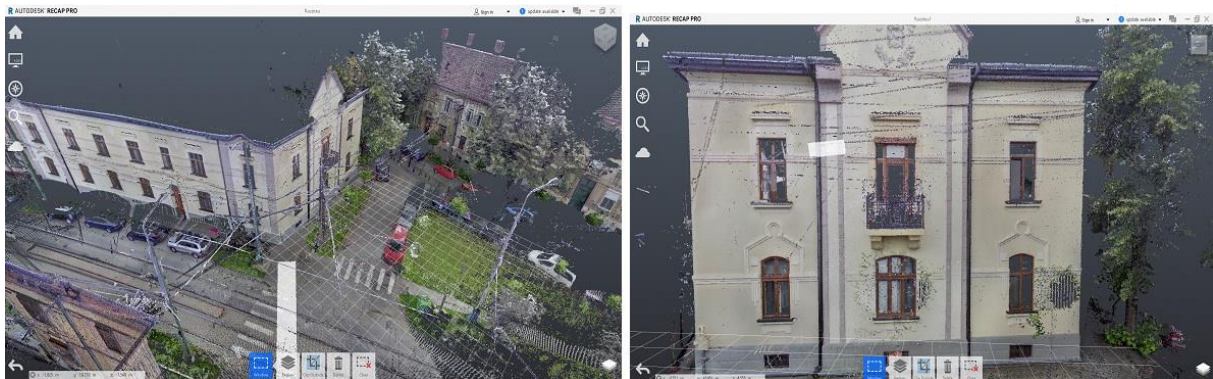

Fig. 6. 3D model after the rehabilitation works

CONCLUSION

Comparing laser scanning method with traditional topographic surveys realized by total stations or with GNSS we can see that the later are much less expensive, offer very high accuracy but their application time is much higher. On the other hand, although laser scanning is much more expensive, it adds extra speed and efficiency to the surveying processes. At the same time, the amount of information received is far greater thus offering varied functionality to laser scanner data. Depending on the complexity of the work, the need for precision and the funds needed for a specific work, we can choose one method or another.

From the financial point of view, topographic methods are far cheaper than 3D laser scanning, since one of the cheapest scanners on the market along with the data processing software can be bought approximately with € 50,000. Instead, measurements can be made with any total station, or GNSS receivers and their costs do not exceed € 10,000.

3D laser scanning technology can acquire 3D point cloud quickly with high accuracy. This meets the needs of historical architecture surveying and protection. 3D laser scanning technology can replace traditional measuring methods completely in historical architecture surveying. 3D point cloud can be gained by laser scanner, then construct the 3D model. In addition, detail structure can be got by close-range photogrammetry method, which produces the orthoimage and linear drawing [7].

Surveying of Historical architecture based on 3D laser scanning technology can not only reduce field work, improve efficiency but also provide different kinds of products such as 3D model, CAD construction drawing and so on. 3D laser scanner is growing towards high speed, high accuracy, large range and multi-information etc. at present. All these will impulse laser scanning application to historical architecture surveying and protection.

As regard the IPA project, it gave everyone involved the opportunity to work with educated adults who very easily mastered the information that was passed on and worked with visible enthusiasm, eager to improve. Thus, the project created the opportunity for teachers of different nationalities to

interact and communicate, to exchange information, share ideas, feelings, research results. Moreover, the project answer to the challenges faced in academia at the moment, namely: the diversification of the student population and its needs, the rapid expansion of the use of technology, the motivation of students for learning, the pressure to develop new skills for future graduates, required by employers and the evolution of society.

The added value of the Cross Border dimension is reflected into the following:

- promoting multidisciplinary teams;
- promoting an integrated program for youngsters: training session, online platform and activities to support youngster in seeking jobs;
- promoting a favourable climate: emphasising that an environment which promotes innovation is a crucial requirement in order to attain goals in terms of technology and innovation;
- promoting motivation: increasing the motivation for youngsters and academic employees in universities and research institutions to enter into self-employment; Increasing the motivation for young people to develop entrepreneurial abilities and competencies in order to become independent (to enter into self-employment);
- promoting skills training and qualifications: strengthening knowledge and skills required in order to set up a business and manage a new company by consolidating the qualifications gained in schools and promoting further training.

ACKNOWLEDGMENT

This work was partially supported by the Interreg-IPA Cross-border Cooperation Romania-Serbia Programme financed by the European Union under the Instrument for Pre-accession Assistance (IPA II) and co-financed by the partner states in the Programme, project code RORS-394, “Through knowledge to business and smart development of Banat”.

REFERENCES

- [1] www.mytes.upt.ro
- [2] Herban, I.S., Vilceanu, C.B., Alionescu, A., Application of close-range photogrammetry to cultural heritage, GeoCAD 2014, National Scientific Symposium with International Participation, May 09 - 10, 2014, Alba Iulia, Romania.
- [3] Vilceanu, C.B., Herban, I.S., Grecea, C., Creating 3D Models of Heritage Objects Using Photogrammetric Image Processing, 11th International Conference of Numerical Analysis and Applied Mathematics ICNAAM 2013, Symposium: Mathematical optimization in modern medicine and engineering, 21-27 September 2013, Rhodes, Greece.
- [4] Herban, I.S., Vilceanu, C.-B., Grecea, C., Road-Structure Monitoring with Modern Geodetic Technologies, Journal of Surveying Engineering, ASCE, Vol. 143 (4), DOI 10.1061/(ASCE)SU.1943-5428.0000218, 2017.
- [5] Vilceanu, C.-B., Herban, S., Meng, Q., Alionescu, A., Using LiDAR for Urban Green Space Monitoring, AIP Conference Proceedings 1863, 430008, 2017.
- [6] Vlad, I., Herban, S., Stoian, M., Vilceanu, C.-B., 3D Model Tools for Architecture and Archaeology Reconstruction, AIP Conference Proceedings 1738, 350005 (2016); DOI: 10.1063/1.4952128, 2018,
- [7] Vilceanu, C.-B., Herban, S., Dungan L.I, 3D scanning and printing, Editura EUROBIT, ISBN 978-973-132-627-6, 2020,
- [8] Dungan, L.I., Cernescu, L.M., Herman, M., Popescu, F., Advising, an indispensable element in training students. Usefulness of POSDRU grants, Economics and Education, pag.54-59, ISBN: 978-1-61804-369-6, 2016.

Session 2.

Energetics and Process Technique

MANUFACTURE OF THERMAL SOUND INSULATION PANELS FROM RASPBERRY AND BLACKBERRY CUTTINGS

Srećko Ćurčić¹, Sandra Milunović Koprivica¹, Milan Vesković¹

¹University of Kragujevac, Faculty of Technical science in Čačak, Čačak, Serbia

e-mail: srecko.curcic@ftn.kg.ac.rs

Abstract: The use of raspberry and blackberry cuttings for the production of thermal insulation boards would significantly reduce the cost of heating energy and better sound insulation indoors, but would reduce the emission of CO₂ and other harmful gases into the atmosphere, which occur as a result of decay or combustion of these residues. Combustion or decay of these raw materials has no cost, but after harvesting these products, these residues must be trimmed and removed. And so every year ... Using defined residues would reduce CO₂ and other emissions by about 30%. The paper presents the results of research on the production of thermosonic insulation boards from raspberry and blackberry cuttings.

Key words: raspberry and blackberry cuttings, thermal sound insulation boards, production

INTRODUCTION

After picking the fruits, the fruiting branches of raspberries and blackberries are pruned, and these cuttings are very few or no use at all. After picking raspberries and blackberries, the parent branches are pruned, and these cuttings have about 10 m³ per hectare of raspberries and about 10 m³ per hectare of blackberries.

Thermal sound insulation boards produced from raspberry and blackberry cuttings would be 20 to 40 percent lower than other thermal sound boards (rock wool, styrofoam, etc.). Rational use of raspberry and blackberry cuttings for the production of: thermal sound insulation boards or other purposes would significantly increase the technological level in: energy, mechanical engineering, food industry, etc. Also, the use of these resources would affect the development of underdeveloped regions that can be achieved through: investment realization, employment of local labor, job creation, improvement of local infrastructure and revenue generation through various production activities. Fig. 1. Pictures of raspberry and blackberry cuttings that almost always burn or remain rotten are given [1].

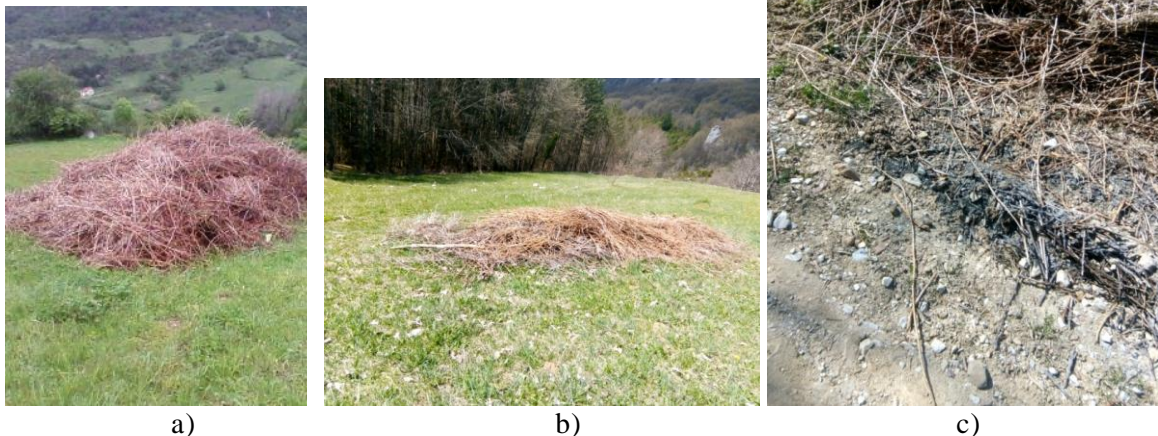

Fig. 1. cuttings: a) raspberries b) blackberries c) burnt cuttings

PRODUCTION OF THERMAL SOUND INSULATION PANELS FROM RASPBERRY AND BLACKBERRY CUTTINGS

For the production of thermo sonic insulation boards, it is necessary to prepare cuttings, and for such cuttings to define the binder, tool, pressure and the period of action of pressure on the tool in which there will be a compact mass of cuttings with appropriate binder.

After defining the preparatory technologies for raspberry and blackberry cuttings, it is necessary to define rational technologies for the production of thermal sound insulation boards for various consumers. To define rational technologies, it is necessary to determine the calibration of cuttings, as well as the appropriate binders that will connect the cuttings into a monolithic whole with the appropriate flow and time of action of pressure.

After adjusting the crusher (Figure 2. [2]) for chopping raspberry and blackberry cuttings, they were chopped when the humidity was around 12%. Humidity was measured with a mobile humidity measuring device. The humidity measuring device is given in Figure 3. The humidity measuring device is from the company ELECTRONIC - Fuchtomesser, and can measure humidity 0d 0 to 100%. The appearance of the crushed cuttings is shown in Figure 4 [4].



Fig. 2. Mobile crusher



Fig. 3. Humidity measuring device



Fig. 4. Appearance of crushed cuttings

After chopping the cuttings, sieving was started with appropriate sieves. The appearance of the stretched chopped cuttings, three calibrations, are shown in Fig. 5, 6 and 7.



Fig. 5



Fig. 6



Fig. 7

Technologies for production and products of raspberry and blackberry cuttings for thermal sound characteristics

For the production of thermo sonic insulating boards, various experiments were performed with calibrated cuttings, binders, tools, pressure force and time of force action. In the following text, the products created as a result of the work on the project "DEVELOPMENT OF TECHNOLOGY FOR THE PRODUCTION OF THERMAL AND SOUND INSULATION BOARDS FROM RASPBERRY AND BLACKBERRY RESIDUES", which is financed by the EBRD within the program "Green Innovation Vouchers". The beneficiary of the results of this project is the company "Drvo-Art" from Čačak. Fig. 8. shows a product that was produced in a mold of medium granulation, and the binder was a carbonic resin. Such products can be used in construction where very good sound and heat insulation performance is required. The sound insulation power is about 20 dB.



Fig. 8. Appearance of raspberry and blackberry cuttings with medium granulation

Fig. 9. shows the product produced from cuttings of various granulations with a binder of carbonide and natural resin. The shaping tool is specially designed. These products can be used in concert and cinema halls, but also in other spaces where it is necessary to provide thermal and sound insulation.



Fig. 9. Appearance of cuttings of various granulations

For the needs of the company "Drvo-Art" from Čačak, a product was produced that can be installed in doors that are in the production program of this company. By the way, the company "Drvo-Art" imports responsive thermal sound materials. The use of these products in the production program of the company would reduce the price of the product by at least 20%. Fig. 10 shows the appearance of products from cuttings of finer granulation, and this product can be applied in the production program of the company "Drvo-Art" from Čačak. The sound insulation power is about 12 dB. Fig. 11. shows the appearance of a product of the same granulation but a different binder.



Fig. 10. Appearance of thermosonic insulation boards for the needs of the company "Drvo-Art" from Čačak.



Fig. 11. Appearance of thermosonic insulation boards for the needs of the company "Drvo-Art" from Čačak.

The volumes of the plates from Fig. 10. and 11. are from 250 kg / m³ to 350 kg / m³ depending on the granulation of the prepackage and the type of binder.

POSSIBILITIES OF APPLICATION OF THERMAL SOUND INSULATION PANELS FROM RASPBERRY AND BLACKBERRY CUTTINGS

Introduction

Residential and commercial buildings are one of the largest consumers of energy. Thermal insulation reduces heat losses in winter, overheating in summer, and protects the load-bearing structure from external conditions and sudden temperature changes. A thermally insulated building is more comfortable, with an extended lifespan, contributes to environmental protection and reduces annual costs for providing thermal comfort. The effect of thermal insulation of buildings depends on the design, the thickness of the insulation layer and the coefficient of thermal conductivity of the applied insulation material. Today on the market, the offer of insulation materials is diverse, but the European market is dominated by conventional insulation materials: mineral wool (glass and stone) and polystyrene (styrofoam). In recent years, many studies have been done on the irritating toxic, even carcinogenic effects of rock and glass wool, which is the main reason for looking for alternative "more environmentally friendly" materials, ie the use of environmentally friendly products for building insulation. The waste from raspberry and blackberry cuttings is very large, but it is one of the environmental pollutants when it ends up in landfills or when it burns, so all phases of its reconstruction in the new product contribute to environmental protection and prevent the loss of valuable resources. The use of raspberry and blackberry cuttings for thermal sound insulation boards will have an ecological and economic component. For the rational use of raspberry and blackberry cuttings for products such as: pellets, briquettes, compost and three-sound insulation boards, the basic conditions are availability and continuous supply in the required quantity, market situation and interest in purchasing these products. End users received positive evaluations of the possibilities of production and use of thermal sound insulation boards from raspberry and blackberry cuttings, which is the basis for further work in this area, especially in the direction of reducing costs and improving product characteristics.

Applications of thermal sound insulation panels of raspberry and blackberry cuttings

One of the most interesting applications of thermal sound insulation panels is thermal and sound insulation of buildings. There are already commercial insulation materials on the market made of different materials in the form of panels or rolls with different thicknesses, which can be used to insulate walls, ceilings and roofs. Most of these products are made of styrofoam, rock wool and cotton fiber-based materials. The design and production of a new product for the insulation of buildings from raspberry and blackberry cuttings is a complex problem that requires an interdisciplinary approach. The first condition for its solution, on the one hand, is a detailed knowledge of the structural and physical characteristics of granules of raspberry and blackberry cuttings and knowledge of the physical characteristics of classical insulation materials on the other hand. Then the problem of new product production technology needs to be solved. Prerequisite is knowledge of the mechanism of heat and sound transfer through products made of them.

Produced thermal insulation boards from raspberry and blackberry cuttings can be 1 cm - 10 cm thick. They can be applied where there are noise problems: in construction, car industry, white goods industry, factory halls, to reduce traffic noise and other special demanding needs. Also, these products can be used for light partition constructions, for the production of prefabricated buildings with decorative space, etc.

The characteristics of thermal sound insulation boards made of raspberry and blackberry residues are: thermal conductivity, sound insulation and mechanical load-bearing capacity.

Sound insulation depends on the dynamic stiffness (s' - unit MN / m³) of insulation boards. The lower the value of dynamic stiffness, the higher the sound insulation power. Good sound insulation materials have a dynamic stiffness value below 50 MN / m³, especially efficient sound insulation materials below 20 MN / m³.

The dynamic stiffness of the thermally sound insulation boards from raspberry and blackberry cuttings is below 25 MN / m³, which ensures a reduction of the impact sound level by a minimum of 20 dB, for

a board thickness of 10 cm. It can be used for use in sloping roofs as a thermal insulation material that is placed between and above the horns of the roof structure and as a filling for internal structures. It is easily installed in ceiling beam systems as a good thermal and sound insulating material.

Thermal insulation boards made of these materials are completely natural, with a low coefficient of thermal conductivity (λ) of about 0.05 W / mK. The lifespan of such boards is extremely long, because its properties are not significantly reduced and it is far longer than other insulating materials, e.g. styrofoam, glass wool, etc.

Comparative analysis of the characteristics of thermal sound insulation boards made of various materials

a) The company in Tavnik (near Kraljevo) produces panels of appropriate materials 20 mm thick and their sound insulation is 43 dB.

b) A 100 mm stone wool panel has a sound insulation of 33 dB.

c) Highway panels have a sound insulation of 25 dB.

d) Sound insulation of a wall of 270 mm from textile waste has a sound insulation of 52 dB.

Not all products have a linear characteristic of the change in sound insulation.

From this previous analysis, it is important to note that the thermal and sound insulation of a new insulation product is comparable to commercial products. To compare the obtained values of thermal insulation of the tested samples, the data from Table 1 will be used [3].

Table 1. Comparison of thermal insulation of a new insulation product with commercial products.

Insulation product	(kg/m ³)	<i>h</i> (mm)	<i>R</i> * (m ² /KW)
New product	80 - 100	100	1.5-1.7
Eurothermal insulation	70-80	70	1.8

According to Table 2, it can be concluded that the new insulation structure of raspberry and blackberry cuttings has a larger bulk density and slightly less thermal insulation compared to insulation materials made of Euromaterials at the same thickness.

Sound insulation measurements were performed with the TROTEC SL300 device given in Fig. 12.



Fig. 12. TROTEC SL300

Barriers to production and the benefit of new raspberry and blackberry cuttings are given in Table 2.

Table 2. Barriers in production and benefit of new products from raspberry and blackberry cuttings

Product	Barriers	Benefit
Filtration systems	Only cheaper products are acceptable	Structures of raspberry and blackberry cuttings can be used
Thermal and sound insulation in the carpentry industry	Product granulation	Large market size
Thermal and sound insulation of buildings	Continuous source of material	There are no such products on the European markets

CONCLUDING REMARKS

During the production of raspberries and blackberries, very large quantities of cuttings remain every year, which, among other things, can be used for the production of thermal sound insulation boards.

Although this waste is a valuable resource because it is new, clean, has retained physical and mechanical properties and does not require any special treatment before production, most of it burns or remains to rot. Barriers to its use are objective and subjective in nature. Subjective barriers are the lack of interest of some producers to use cuttings. Objectively, most of the producers of raspberries and blackberries are small and medium in size with insufficient quantities for rational use due to the location and the necessary infrastructure.

The technological line for the production of thermal insulation products is quite simple: chopping, sieving, mixing granules with binders, pouring into molds and pressing compact mass in a defined time interval. The structure obtained in this way is cheap, it has good thermal and sound insulation. The coefficient of thermal conductivity λ is in the range from 0.05 to 0.06, and thermal insulation from 1.5 to 1.7. The values of these characteristics are comparable with commercial insulation materials, both with conventional (mineral wool and styrofoam) and with insulation products made of recycled textiles in the form of fibers.

Slabs with an untreated surface, from the remains of raspberries and blackberries very well absorb sound. They can be used for interior sound insulation: in classrooms, sports halls, workshops, concert and cinema halls, studios, etc., and panels with a finer fiber structure can be used, which can also be a decorative element in the space.

In terms of prices, the prices of thermal sound insulation boards can be at least 20% lower compared to the products offered on the market made of stone wool and styrofoam.

Bearing in mind that raspberry and blackberry cuttings are used as raw material, which occur continuously every year, this is not a problem but an excellent opportunity to reduce environmental pollution and to obtain cheap and environmentally friendly sound and thermal insulation.

ACKNOWLEDGMENT

The research presented in this paper is partially funded RS Ministry of Education, Science and Technological Development, contract no. 451-03-68 / 2020-14 / 200132 whose implementer is the Faculty of Technical Sciences in Čačak - University of Kragujevac.

REFERENCES

- [1] Curcic, S., Zizovic, M., Milunovic Koprivica, S., Veskovic, M., Turanjanin, D., Multicriteria analysis of production alternatives of raspberry and blackberry production residues, *QUAESTUS Multidisciplinary Research Journal* Nr 17/ IUNIE 2020(ANUL IX) pp. 153-158, 2020.
- [2] Švaić, S., *Proizvodnja toplinske energije iz drvne biomase, Međunarodno savjetovanje i radionica „Izazovi strategije zaštite okoliša i održivog razvoja“*, Fakultet strojarstva i brodogradnje Zagreb, Zagreb, 2005.

- [3] Al-Homoud, S.M, The Effectiveness of Thermal Insulation in Different Types of Buildings in Hot Climates, *Journal of Thermal Envelope and Building Science*, Vol. 27, No.3, pp. 235-247, 2004.
- [4] Tammemagi, H., *Waste Crisis*, Oxford University Press, pp.19 -34, 51-53, 2000.
- [5] Tremier, A. et al., *Global Assessment for Organic Resources and Waste Mangement ORBIT 2012*, *Waste and Biomass Valorization*, Vol. 5, No. 3, pp. 429-431, 2014.
- [6] Božić, L.A., Kušić. H., *Upravljanje Otpadom*, Sveučilište u Zagrebu, Zagreb, pp.1-3,8-13, 2012.

GENERALIZED DIFFERENTIAL QUADRATURE METHOD FOR STUDYING THE IN-PLANE VIBRATIONS OF CURVED PIPES CONVEYING FLUID

Svetlana Lilkova-Markova¹, Dimitar Lolov¹

¹University of Architecture, Civil Engineering and Geodesy, Faculty of Hydraulic
Engineering, Sofia, Bulgaria

e-mail: lilkova_fhe@uacg.bg, dlolov@yahoo.com

Abstract: A curved pipe bent in the arc of a circle conveying fluid is investigated. The flowing fluid is considered as a non-compressible and heavy. The considered pipe is assumed hinged at its both ends. The Generalized Differential Quadrature Method is employed to investigate the dynamic stability of the pipe. The obtained numerical results show the dependence of the critical fluid velocity on the maximal central angle of the pipe.

Key words: curved pipe, fluid, circular frequency, flow velocity, GDQM

INTRODUCTION

The interaction of a tube and a fluid flowing in it is the subject of much research. The dynamic characteristics of the pipe's oscillations depend on the velocity and the mass of the conveyed fluid. The research of the dynamic stability of pipes conveying fluid is branched into two directions: a) dynamic stability of pipes with a rectilinear axis and b) dynamic stability of curved pipes.

Misra A., Paidoussis M. and Van K. consider in [6] curved pipes conveying fluid. The method of finite elements is used for the solution of the differential equation describing the problem. In [1] Y.Huang et al. apply the matrix method to study the dynamic stability of curved pipes with a flowing fluid. The axes of the investigated tubes are arcs of a circle or are represented by segments that are such arcs. F. Liang et al. in [3] consider the complex mode method for obtaining the in-plane vibration frequency of a clamped-clamped curved pipe. T. Irie et al. in [2] examine the free in-plane oscillations of beams bent in the arc of a circle. Timoshenko's theory is applied. The beams have a rectangular or circular cross section.

Q. Zhao, Q. and Z. Sun [9] use the Green function method in the investigation of the in-plane forced vibration of a curved pipe conveying fluid.

The Generalised Differential Quadrature Method (GDQM) is used in [7] from P. Soltani and M.Saadati to solve the differential equations describing the oscillations of a nanotube delineated by a curve. This method is widely used in various engineering tasks and gives good convergence at a small number of characteristic points. In the article the in-plane oscillations of a nanotube with an axis bent in the arc of a circle and lying on a Winkler elastic foundation are investigated.

In the article [8] with authors F. Tornabene et al. the critical fluid velocity in a rectilinear cantilever tube is investigated. The GDQM is applied for the solution of the differential equation describing the oscillations of the pipe. A linear system of algebraic equations is obtained and the corresponding eigenvalue problem is solved in order to investigate the stability of the pipe.

D. Lolov and S. Lilkova-Markova in [5] investigate the dynamic stability of a single-walled carbon nanotube with the employment of the GDQM. The tube under investigation is assumed hinged at its both ends and is embedded in a polymer matrix. The obtained numerical results are for flowing fluids with different densities. In order to study the effect of the surrounding elastic medium (such as polymer) on the stability of the pipe the Winkler elastic foundation is introduced. The critical velocities of each type of fluid are determined for different stiffness of this matrix.

The aim of this paper is to obtain the critical velocity of a fluid flowing in a tube with an axis bent in the arc of a circle. The investigated pipe is hinged at its both ends. The Generalized Differential Quadrature Method is applied.

IN PLANE VIBRATION OF CURVED PIPE CONVEYING FLUID

The present paper investigates the in-plane stability of curved pipes, conveying fluid. The static scheme of the pipe under consideration is shown in Fig. 1. The pipe is bent in the form of an arc of a circle with radius R . The material of the pipe is linear elastic with Young's modulus E . The cross-sectional parameters are area A and axis moment of inertia I . The fluid flowing in the pipe is heavy and non-compressible.

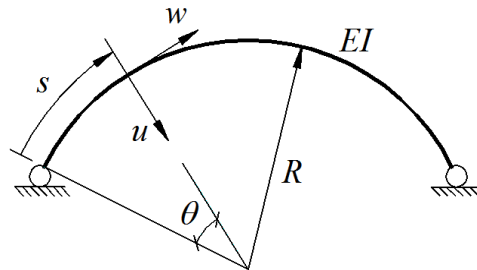

Fig. 1. Static scheme of the investigated pipe conveying fluid

The differential equations of the free in-plane vibrations of the pipe written about the axes of the natural coordinate system, shown in [4], are

$$-EI \left(\frac{\partial^4 u}{\partial s^4} + \frac{1}{R} \frac{\partial^3 w}{\partial s^3} \right) + \frac{EA}{R} \left(\frac{\partial w}{\partial s} - \frac{u}{R} \right) - MV^2 \left(\frac{\partial^2 u}{\partial s^2} + \frac{1}{R} \frac{\partial w}{\partial s} \right) - 2MV \left(\frac{\partial^2 u}{\partial s \partial t} + \frac{1}{R} \frac{\partial w}{\partial t} \right) - (M+m) \frac{\partial^2 u}{\partial t^2} = 0 \quad (1)$$

$$\frac{EI}{R} \left(\frac{\partial^3 u}{\partial s^3} + \frac{1}{R} \frac{\partial^2 w}{\partial s^2} \right) + EA \left(\frac{\partial^2 w}{\partial s^2} - \frac{1}{R} \frac{\partial u}{\partial s} \right) + MV \left(\frac{1}{R} \frac{\partial u}{\partial t} - \frac{\partial^2 w}{\partial s \partial t} \right) - (M+m) \frac{\partial^2 w}{\partial t^2} = 0 \quad (2)$$

where t is the time, u is the displacement on the normal of the curve and w that on the tangent, and s is the curvilinear abscissa. The mass of the pipe per unit length is denoted by m and the mass of the fluid per unit length of the pipe by M . V is the flow velocity

For convenient reasons the curvilinear abscissa s in (1) and (2) is expressed by the central angle θ . The following equations are obtained

$$-\frac{EI}{R^4} \left(\frac{\partial^4 u}{\partial \theta^4} + \frac{\partial^3 w}{\partial \theta^3} \right) + \frac{EA}{R^2} \left(\frac{\partial w}{\partial \theta} - u \right) - \frac{MV^2}{R^2} \left(\frac{\partial^2 u}{\partial \theta^2} + \frac{\partial w}{\partial \theta} \right) - \frac{2MV}{R} \left(\frac{\partial^2 u}{\partial \theta \partial t} + \frac{\partial w}{\partial t} \right) - (M+m) \frac{\partial^2 u}{\partial t^2} = 0 \quad (3)$$

$$\frac{EI}{R^4} \left(\frac{\partial^3 u}{\partial \theta^3} + \frac{\partial^2 w}{\partial \theta^2} \right) + \frac{EA}{R^2} \left(\frac{\partial^2 w}{\partial \theta^2} - \frac{\partial u}{\partial \theta} \right) + \frac{MV}{R} \left(\frac{\partial u}{\partial t} - \frac{\partial^2 w}{\partial \theta \partial t} \right) - (M+m) \frac{\partial^2 w}{\partial t^2} = 0 \quad (4)$$

Each function of the displacements w and u is presented as a product of two functions:

$$w(\theta, t) = W(\theta) e^{\omega t} \quad (5)$$

$$u(\theta, t) = U(\theta) e^{\omega t} \quad (6)$$

where ω is the circular frequency

Then the equations (3) and (4) will be

$$-\frac{EI}{R^4}\left(\frac{\partial^4 U}{\partial \theta^4} + \frac{\partial^3 W}{\partial \theta^3}\right) + \frac{EA}{R^2}\left(\frac{\partial W}{\partial \theta} - U\right) - \frac{M V^2}{R^2}\left(\frac{\partial^2 U}{\partial \theta^2} + \frac{\partial W}{\partial \theta}\right) - \frac{2 M V \omega}{R}\left(\frac{\partial U}{\partial \theta} + W\right) - (M + m)\omega^2 U = 0 \quad (7)$$

$$\frac{EI}{R^4}\left(\frac{\partial^3 U}{\partial \theta^3} + \frac{\partial^2 W}{\partial \theta^2}\right) + \frac{EA}{R^2}\left(\frac{\partial^2 W}{\partial \theta^2} - \frac{\partial U}{\partial \theta}\right) + \frac{M V \omega}{R}\left(U - \frac{\partial W}{\partial \theta}\right) - (M + m)\omega^2 W = 0 \quad (8)$$

New dimensionless parameters are introduced:

$$\xi = \frac{W}{R}; \phi = \frac{U}{R}; \nu = VR\sqrt{\frac{M}{EI}}; \beta = \frac{M}{M + m}; k^2 = \frac{I}{A R^2}; \Omega = R^2 \omega \sqrt{\frac{(M + m)}{EI}} \quad (9)$$

After transformations, the differential equations (7) and (8) take the forms:

$$k^2\left(\frac{\partial^4 \phi}{\partial \theta^4} + \frac{\partial^3 \xi}{\partial \theta^3}\right) - \left(\frac{\partial \xi}{\partial \theta} - \phi\right) + k^2 \nu^2 \left(\frac{\partial^2 \phi}{\partial \theta^2} + \frac{\partial \xi}{\partial \theta}\right) + 2 \nu k^2 \Omega \sqrt{\beta} \left(\frac{\partial \phi}{\partial \theta} + \xi\right) + \Omega^2 k^2 \phi = 0 \quad (10)$$

$$k^2\left(\frac{\partial^3 \phi}{\partial \theta^3} + \frac{\partial^2 \xi}{\partial \theta^2}\right) + \left(\frac{\partial^2 \xi}{\partial \theta^2} - \frac{\partial \phi}{\partial \theta}\right) + \nu k^2 \Omega \sqrt{\beta} \left(\phi - \frac{\partial \xi}{\partial \theta}\right) - \Omega^2 k^2 \xi = 0 \quad (11)$$

The dimensionless differential governing equations of motion (10) and (11) can be transformed into a system of algebraic equations by means of the Generalized Differential Quadrature Method (GDQM) [7], [8]. The basic idea of the method is to approximate a derivative of a function at any discrete point of a domain as a weighted linear sum of function values at all discrete points, expressing mathematically as follows.

$$\left.\frac{d^n \phi(\theta)}{d \theta^n}\right|_{\theta=\theta_i} = \sum_{j=1}^m \beta_{ij}^{(n)} \phi(\theta_j), \quad i = 1, \dots, m \quad (12)$$

$$\left.\frac{d^n \xi(\theta)}{d \theta^n}\right|_{\theta=\theta_i} = \sum_{j=1}^m \beta_{ij}^{(n)} \xi(\theta_j), \quad i = 1, \dots, m \quad (13)$$

where m is the total number of the sampling points of the chosen grid on the axis of the pipe, $\beta_{ij}^{(n)}$ is the weighting coefficient corresponding to the n -th order derivative at point i .

In the present paper the Chebyshev-Gauss-Lobatto point distribution is assumed [8]:

$$\theta_i = \frac{1}{2} \left[1 - \cos\left(\frac{i-1}{m-1} \pi\right) \right], \quad i = 1, \dots, m \quad (14)$$

The weighting coefficients are calculated by means of Lagrange interpolating functions. For the first derivative, the weighting coefficients are calculated as [8]:

$$\beta_{ij}^{(1)} = \frac{L^{(1)}(\theta_i)}{(\theta_i - \theta_j)L^{(1)}(\theta_j)}, \quad i, j = 1, \dots, m, i \neq j \quad (15)$$

$$\beta_{ii}^{(1)} = - \sum_{j=1, j \neq i}^m \beta_{ij}^{(1)}, \quad i, j = 1, \dots, m \quad (16)$$

while for higher order derivatives, ones gets iteratively

$$\beta_{ij}^{(n)} = n \left(\beta_{ii}^{(n-1)} \beta_{ij}^{(1)} - \frac{\beta_{ij}^{(n-1)}}{\xi_i - \xi_j} \right), \quad i, j = 1, \dots, m; i \neq j; n = 2, \dots, (m-1) \quad (17)$$

$$\beta_{ii}^{(n)} = - \sum_{j=1, j \neq i}^m \beta_{ij}^{(n)}, \quad i, j = 1, \dots, m; \quad n = 2, \dots, (m-1) \quad (18)$$

Where the first derivative of Lagrange interpolating polynomials at each point θ_k in equation (15) is defined as

$$L^{(1)}(\xi_k) = \prod_{l=1, l \neq k}^m (\xi_k - \xi_l), \quad k = 1, \dots, m \quad (19)$$

The Lagrange interpolating polynomials in conjunction with Chebyshev-Gauss-Lobatto sampling points of equation (14) ensures convergence, so that the increasing number of sampling points leads to an error decrease.

Through the GDQM the governing equations (10) and (11) are rewritten in discrete form at the points $i = 3, 4, \dots, (m-1)$.

$$\begin{aligned} & k^2 \left(\sum_{j=1}^m \beta_{ij}^{(4)} \phi(\theta_j) + \sum_{j=1}^m \beta_{ij}^{(3)} \xi(\theta_j) \right) - \left(\sum_{j=1}^m \beta_{ij}^{(1)} \xi(\theta_j) - \phi(\theta_j) \right) + k^2 v^2 \left(\sum_{j=1}^m \beta_{ij}^{(2)} \phi(\theta_j) + \sum_{j=1}^m \beta_{ij}^{(1)} \xi(\theta_j) \right) + \\ & + 2 v k^2 \Omega \sqrt{\beta} \left(\sum_{j=1}^m \beta_{ij}^{(1)} \phi(\theta_j) + \xi(\theta_j) \right) + \Omega^2 k^2 \phi(\theta_j) = 0 \end{aligned} \quad (20)$$

$$\begin{aligned} & k^2 \left(\sum_{j=1}^m \beta_{ij}^{(3)} \phi(\theta_j) + \sum_{j=1}^m \beta_{ij}^{(2)} \xi(\theta_j) \right) + \left(\sum_{j=1}^m \beta_{ij}^{(2)} \xi(\theta_j) - \sum_{j=1}^m \beta_{ij}^{(1)} \phi(\theta_j) \right) + \\ & + v k^2 \Omega \sqrt{\beta} \left(\phi(\theta_j) - \sum_{j=1}^m \beta_{ij}^{(1)} \xi(\theta_j) \right) - \Omega^2 k^2 \xi(\theta_j) = 0 \end{aligned} \quad (21)$$

The boundary conditions for the pipe shown in Fig 1 are:

$$\phi(\theta_1) = \xi(\theta_1) = \phi(\theta_m) = \xi(\theta_m) = 0; \quad M(\theta_1) = M(\theta_m) = 0 \quad (22)$$

The differential equation of the elastic line of a beam outlined on a circle is:

$$M = -EI \left(\frac{d^2 u}{d s^2} + \frac{u}{R^2} \right) \quad (23)$$

From (23) the last two boundary conditions in (22) take the form:

$$\left. \frac{d^2 \phi(\theta)}{d \theta^2} \right|_{\theta=\theta_1} = \left. \frac{d^2 \phi(\theta)}{d \theta^2} \right|_{\theta=\theta_m} = 0 \quad (24)$$

Equations (20) и (21), can be rewritten in the following matrix form:

$$\begin{aligned} & \left[k^2 B^{(4)} + k^2 v^2 B^{(2)} + 2vk^2 \Omega \sqrt{\beta} B^{(1)} \right] \delta_1 + \left[k^2 B^{(3)} - B^{(1)} + k^2 v^2 B^{(1)} \right] \delta_2 + (\Omega^2 k^2 + 1) \delta_{1d} + \\ & + 2vk^2 \Omega \sqrt{\beta} \delta_{2d} = 0 \end{aligned} \quad (25)$$

$$\left[k^2 B^{(3)} - B^{(1)} \right] \delta_1 + \left[k^2 B^{(2)} + B^{(2)} \right] \delta_2 + vk^2 \Omega \sqrt{\beta} \delta_{1d} - (\Omega^2 k^2 + vk^2 \Omega \sqrt{\beta}) \delta_{2d} = 0 \quad (26)$$

in (25) and (26)

$$B_{ij}^{(4)} = \beta_{ij}^{(4)}; \quad B_{ij}^{(2)} = \beta_{ij}^{(2)}; \quad B_{ij}^{(1)} = \beta_{ij}^{(1)}, \quad i = 3, 4, \dots, (m-1), \quad j = 1, \dots, m \quad (27)$$

$$\delta_1 = \{\phi(\theta_1), \dots, \phi(\theta_m)\}^T \quad (28)$$

$$\delta_{1d} = \{\phi(\theta_3), \dots, \phi(\theta_{m-1})\}^T \quad (29)$$

$$\delta_2 = \{\xi(\theta_1), \dots, \xi(\theta_m)\}^T \quad (30)$$

$$\delta_{2d} = \{\xi(\theta_3), \dots, \xi(\theta_{m-1})\}^T \quad (31)$$

The six boundary conditions (22) are also written in a matrix form.

$$K_b \delta = 0 \quad (32)$$

where

$$\delta = \{\delta_1 \quad \delta_2\}^T \quad (33)$$

$$K_b = \begin{pmatrix} 1 & \dots & 0 & 0 & \dots & 0 \\ 0 & \dots & 1 & 0 & \dots & 0 \\ 0 & \dots & 0 & 1 & \dots & 0 \\ 0 & \dots & 0 & 0 & \dots & 1 \\ \beta_{11}^{(2)} & \dots & \beta_{1m}^{(2)} & 0 & \dots & 0 \\ \beta_{m1}^{(2)} & \dots & \beta_{mm}^{(2)} & 0 & \dots & 0 \end{pmatrix} \quad (34)$$

The discrete field (25) and (26) can be combined with the boundary conditions (32) into m algebraic equations with m unknown nodal displacements as follows

$$\begin{pmatrix} K_b \\ B_1 \\ B_2 \end{pmatrix} \delta + \begin{pmatrix} O_{2m \times 6} \\ K_{1d} \\ K_{2d} \end{pmatrix} \begin{pmatrix} O_{6 \times 1} \\ \delta_{1d} \\ \delta_{2d} \end{pmatrix} = 0 \quad (35)$$

$$B_1 = \begin{vmatrix} k^2 B^{(4)} + k^2 v^2 B^{(2)} + 2vk^2 \Omega \sqrt{\beta} B^{(1)} & k^2 B^{(3)} - B^{(1)} + k^2 v^2 B^{(1)} \end{vmatrix} \quad (36)$$

$$B_2 = \begin{vmatrix} k^2 B^{(3)} - B^{(1)} & k^2 B^{(2)} + B^{(2)} \end{vmatrix} \quad (37)$$

Where B_1 and B_2 are $(m-3) \times 2m$ matrixes.

$$K_{1d} = \begin{vmatrix} O_{(m-3) \times 6} & (\Omega^2 k^2 + 1) I_{(m-3) \times (m-3)} & 2vk^2 \Omega \sqrt{\beta} I_{(m-3) \times (m-3)} \end{vmatrix} \quad (38)$$

$$K_{2d} = \begin{vmatrix} O_{(m-3) \times 6} & k^2 v \Omega \sqrt{\beta} I_{(m-3) \times (m-3)} & -(\Omega^2 k^2 + vk^2 \Omega \sqrt{\beta}) I_{(m-3) \times (m-3)} \end{vmatrix} \quad (39)$$

where K_{1d} and K_{2d} are $(m-3) \times 2m$ matrixes

In order to calculate the natural frequencies of the pipe, equation (35) is reorganized of the following form

$$\begin{vmatrix} K_{bb} & K_{bd} \\ B_{db} & B_{dd} \end{vmatrix} \begin{Bmatrix} \delta_b \\ \delta_d \end{Bmatrix} + \begin{vmatrix} O_{2m \times 6} \\ K_{1d} \\ K_{2d} \end{vmatrix} \begin{Bmatrix} O_{6 \times 1} \\ \delta_d \end{Bmatrix} = 0 \quad (40)$$

$$\delta_d = \begin{Bmatrix} \delta_{1d} \\ \delta_{2d} \end{Bmatrix} \quad (41)$$

$$\delta_b = \begin{Bmatrix} \phi(\theta_1) \\ \phi(\theta_2) \\ \phi(\theta_m) \\ \xi(\theta_1) \\ \xi(\theta_2) \\ \xi(\theta_m) \end{Bmatrix} \quad (42)$$

$$K_{bb} = \begin{vmatrix} 1 & 0 & 0 & 0 & 0 & 0 \\ 0 & 0 & 1 & 0 & 0 & 0 \\ 0 & 0 & 0 & 1 & 0 & 0 \\ 0 & 0 & 0 & 0 & 0 & 1 \\ \beta_{11}^{(2)} & \beta_{12}^{(2)} & \beta_{1m}^{(2)} & 0 & 0 & 0 \\ \beta_{m1}^{(2)} & \beta_{m2}^{(2)} & \beta_{mm}^{(2)} & 0 & 0 & 0 \end{vmatrix} \quad (43)$$

$$K_{db} = \begin{vmatrix} 0 & \dots & 0 & 0 & \dots & 0 \\ 0 & \dots & 0 & 0 & \dots & 0 \\ 0 & \dots & 0 & 0 & \dots & 0 \\ 0 & \dots & 0 & 0 & \dots & 0 \\ \beta_{13}^{(2)} & \dots & \beta_{1(m-1)}^{(2)} & 0 & \dots & 0 \\ \beta_{m3}^{(2)} & \dots & \beta_{m(m-1)}^{(2)} & 0 & \dots & 0 \end{vmatrix} \quad (44)$$

$$\delta_b = -K_{bb}^{-1} K_{bd} \delta_d \quad (45)$$

Equation (40) represents an eigenvalue problem. For different values of the non-dimensional velocity v are obtained the non-dimensional natural frequencies Ω . If $\text{Re}\Omega < 0$ the system is stable. At

$Re\Omega = 0$ the system is at the edge of loss of stability, the corresponding fluid velocity is the critical fluid velocity.

RESULTS AND DISCUSSION

Numerical studies have been carried out for the fluid flowing pipe in Fig. 1.

The geometric and the material characteristics of the pipes are: the radius $R=20\text{ m}$, the inner and the outer radii of the cross-section of the pipes are $r_{inner}=0,095\text{ m}$ and $r_{outer}=0,01\text{ m}$, Young's modulus $E=210\text{ GPa}$, the density of the material of the pipe $\rho=7800\text{ kg/m}^3$. The density of the flowing fluid is $\rho=1000\text{ kg/m}^3$.

The critical non-dimensional flow velocity v_{cr} is obtained for different values of θ_{max} . The results are shown in Fig.2. It is obvious that increasing the θ_{max} lowers the critical fluid velocity v_{cr} .

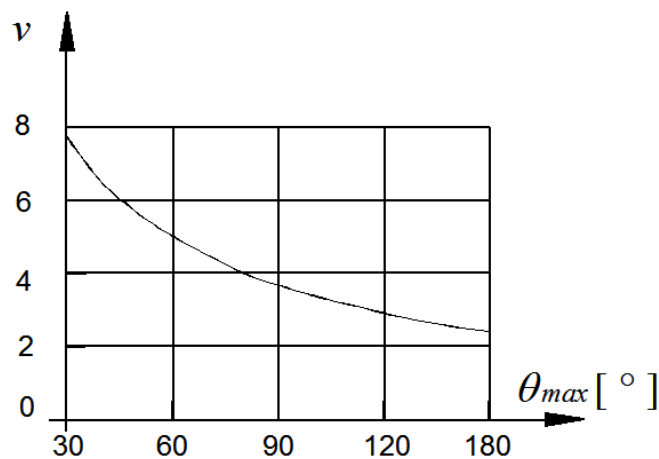

Fig. 2. Dependence of the critical non-dimensional fluid velocity on θ_{max} :

CONCLUSION

The employed GDQ method in the paper allows relatively easy determination of the first natural frequencies of the in- plane vibrations of pipes with axes bent in the arc of circle and with flowing fluid. The method could be competitive with other established approaches for investigating the dynamic stability of the pipes conveying fluid like the Matrix method.

The results show the dependence of the critical non-dimensional fluid velocity of the system on θ_{max} . Increasing the θ_{max} leads to decrease in the critical velocity.

REFERENCES

- [1] Huang, Y., Zeng, G., Wei, F., A new matrix method for solving vibration and stability of curved pipes conveying fluid, Journal of Sound and Vibration, Vol.251 (2), pp. 215-225, 2002.
- [2] Irie, T., Yamada, G., Tanaka, K., Natural frequencies of in-plane vibration of arcs, Journal of Applied Mechanics, Vol.50, pp. 449-452, 1983.
- [3] Liang, F., Yang, X.-D., Bao, R.-D., Zhang, W., Frequency Analysis of Functionally Graded Curved Pipes Conveying Fluid, Advances in Materials Science and Engineering, Vol.2016, Article ID 7574216, 2016.
- [4] Lolov, D., Lilkova-Markova S., Stability of curved pipe outlined on an arc of circle, Mechanics, Transport, Communications, Vol.12, 3/3, 2014.
- [5] Lolov, D., Lilkova-Markova S., Determination of the critical velocity of the fluid flowing in a carbon nanotubes, embedded in a polymer matrix, using the generalized quadrature method,

- Proceedings of International scientific conference Technics, Technologies, Education.Safety, Vol. 2 (5), pp. 231-233, 2018.
- [6] Misra, A., Paidoussis M., Van K., On the dynamics of curved pipes transporting fluid. Part I: Inextensible theory, *Journal of Fluids and Structures*, Vol.2, Issue 3, pp. 221-244, 1988.
- [7] Soltani, P., Saadati, M., Application of generalized quadrature rule to vibration of a curved carbon nanotube on elastic foundation, *The Sixteenth International Congress on Sound and Vibration*, Krakow, 5-9 July 2009.
- [8] Tornabene, F., Marzani, A., Viola, E., Elishakoff, I., Critical flow speeds of pipes conveying fluid using the generalized differential quadrature method, *Adv. Theor. Appl. Mech.*, Vol.3, pp.121-138, 2010.
- [9] Zhao, Q., Sun, Z., In-plane forced vibration of curved pipe conveying fluid by Green function method, *Applied Mathematics and Mechanics (English Edition)*, Vol.38, Issue 10, pp. 1397-1414, 2017.

TECHNICAL AND TECHNOLOGICAL PARAMETER ANALYSIS OF HAMMER MILL CRUSHER

Slavica Prvulović¹, Jasna Tolmač¹, Milica Josimović¹, Vladimir Jakovljević¹,
Aleksandra Božović¹

¹University of Novi Sad, Technical Faculty “Mihajlo Pupin”, Zrenjanin, Serbia
e-mail: prvulovic Slavica@yahoo.com

Abstract: The basic characteristics of the hammer mill crusher as well as the analysis of technological parameters during its operation are presented in the paper. The capacity of the hammer mill crusher was analyzed. The granulometric composition of the coal at the inlet of the grinding plant was determined, as well as the granulometric composition of the coal at the outlet of the grinding plant, which is represented by appropriate diagrams.

Key words: Hammer mill crusher, coal, capacity, performance characteristics biodiesel, production, energy fuel

INTRODUCTION

Modern methods of ore exploitation on surface mines from economical standpoint, but also from the safety standpoint demand top quality equipment for corresponding technological processes in production. The technological processes for refining the ore into the final product and the rectification for further molding and application for other technological processes, involve the use of crushers of various sizes, types and shapes, depending on the material being processed and the shapes and sizes we want to produce [1, 2]. One of the segments of the industry where crushers find their use is the process of coal processing, primarily for the needs of electricity production in thermal power plants, as well as for the needs of other industries, i.e. consumer goods. The use of crushers in this process allows the production of crushed coal of a certain size, or granulometric composition, which is determined by the requirements of the technological process in thermal power plants [3, 4].

MATERIAL AND METHODS

Technical characteristics of hammer mill crusher Global production of biodiesel

A hammer mill crusher with rollers is an impact crusher with hammers in which the delivered material is repeatedly beaten by hammer on the rotor, which spins very quickly, and is placed between two groups of rollers. Repeated rejection of the material on the moving rollers gives the required granulation and thus shreds the material through the outlet [1, 4, 5].



Fig. 1. Hammer mill Crusher (Exterior and section)

The workspace consists of a rotor, a group of rollers and a crusher box.

The size of the crusher is determined by the diameter of the rotor with straightened hammers and by the width of the workspace.

Hammer crushers are of nominal capacity 1350 t/h with electric motor power 1000 kW and at rpm $n=593 \text{ min}^{-1}$ (angular hammer velocity is about 49 m / s). The total number of hammers on the crusher (Fig. 2) is in 8 rows, $8 \times 13 = 104$ pieces.



Fig. 2. Crushers drills in idle position

Hammer crusher is used for grinding material with high contents of clay. The use of these devices enables grinding of coal, lignite, limestone from loam, raw kaolin, clay gypsum, bauxite, bricks and ceramic materials. KDV crushers are used for grinding coal and lignite with moisture content up to 50%, adhesive material and clay up to 25%, crude kaolin with moisture content up to 25%, clay gypsum with moisture content up to 18%, as well as bauxite, bricks and raw ceramic material strength up to 14 MPa. KDV crushers cover a wide range of capacities. They can be mounted on steel and semi-movable structures. They can also be mounted on a common frame and flexible stand, as part of the assembly. The most common application of hammer crushers is in energetics, ceramics and cement production plants [2, 6, 7].

Hammer mill Crusher Construction

The crusher consists of a lower part of the crate which is welded and reinforced from the inside. The bearing house is placed on the cantilever brackets, with a double row oscillating roller bearing and a grease injection device is mounted. A rotor shaft is installed through the bearings and housings. A rotor flywheel is mounted on its lofty end. A lower roller is mounted on either side of the rotor in the crate. The rotor consists of welded plates through which a shaft passes through which are hammered with spacer tubes.

The main working element of the crusher is the rotor, which rotates at high velocity while grabbing the material and grinding it with hammers (Fig. 3.). Rotor consists of welded round plates on which the hammers are slid on with distant pipes, through which the shaft passes. The total number of hammers on the crusher in 13 rows of plates of 8 pieces is 104 pieces. The diameter of the rotor is 1600 mm, while the width of the useful part of the rotor is 2200 mm. The rotor rotates at 600 revolutions per minute and is powered by a 1000 kW electric motor.

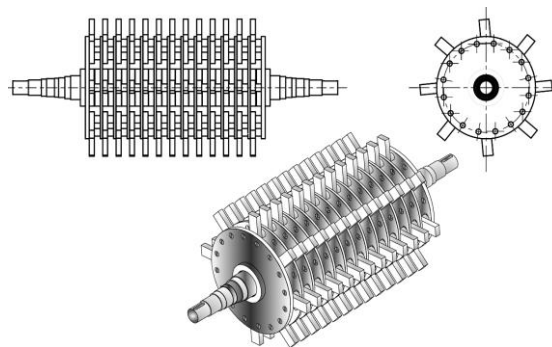

Fig. 3. Crushers rotor with hammers

The size of crushed coal depends on the degree of wear-out of the hammer, although this dependency can't be seen clearly from the result of granulometric composition analysis. Uneven wear-out of the hammer along the width of the shaft and inability of adequate adjustment of the clearance between hammer and lower bumper has a bigger impact on the size of crushed coal [1, 2, 8].

The following picture (Fig. 4.) shows the uneven wear-out of the hammers and their length in millimeters, on some of the crusher shafts.



Fig. 4. Uneven wear-out of the hammer along the axis or width of the rotor

RESULTS AND DISCUSSION

Determination of the hammer mill crusher capacity

The capacity of impact crushers depends on a great extent on the characteristics of the raw material than is the case with other types of crushers. The capacity depends on the size of the rotor (diameter and length) and the number of rotations of the rotor, the number and weight of the hammer, the crumbling of the raw material, the moisture and clay content and the degree of grinding.

The capacity of hammer crushers can only be calculated approximately. The recommendations of the manufactureris often adopted because they are considered reliable in the matter of capacity. For calculation of hammer crusher capacity, the following form is recommended [6]:

$$Q = \frac{0,8 \cdot P}{W} \text{ [t/h]} \quad (1)$$

Where:

Q –Crusher capacity [t/h]

P –Electric motor power [kW]

W –Specific energy consumption for grinding [kWh/t]

Specific energy consumptionis determined by the Fred Bond equation:

$$W = K \cdot W_i \cdot \left(\frac{10}{\sqrt{D}} - \frac{10}{\sqrt{F}} \right) \text{ [kWh/t]} \quad (2)$$

Where:

K –Grinding coefficient (For medium grinding 1, for fine grinding 1, 4);

W_i– Bonds work index [kW h/t], characteristic material constant obtained experimentally;

D - The size of the square mesh opening through which 80% of the crushed product passes [μm];

F - The size of the square opening of the sieve through which 80% of the feedstock passes [μm];

For the calculation of the Fred Bond form, the following values have been adopted (projected capacity of field fields "Field G" and "Dark West Field", a total of 12 million tons of coal per year):

$K = 1$ for medium grinding;

$W_i = 14,3$ [kW h/t] – Bondswor index of grinding for coal

$P_{80} = 25\ 000$ [μm] – adopted;

$F_{80} = 200\ 000$ [μm] – adopted.

According to the adopted values, the following specific energy consumption per ton of coal is obtained:

$$W = 0,584 \text{ kWh/t}$$

Using the empirical formula, the power of an impact crusher electric motor can be calculated:

$$P = 0,15 \cdot D^2 \cdot L \cdot n \text{ [kW]} \tag{3}$$

Where:

D – rotor diameter [m];

L - rotor length [m];

n - o/min, number of rotor revolutions [min^{-1}].

$$P = 6,92 \text{ kW}$$

For the installed power of a 1000 kW hammer crusher electric motor, the following capacity is obtained:

$$Q = 1\ 369,6 \text{ t/h}$$

The obtained value is in accordance with the declared capacity of the manufacturer of this crusher of 1350 t / h, noting that this value changes in real conditions of operation of the device due to any change in the granulometric composition of the inserted coal.

The degree of grinding in impact crushers in practice is rarely greater than 10, and in exceptional cases may reach a value of 40.

Determination of the granulometric composition of grinded coal

The figures below (Fig.5., Fig.6.) show the graphical granulometric composition of the coal at the inlet of the crusher and at the exit of the crusher, according to the values of P and F shown in the calculation of the capacity of the crusher, and the cumulative curves of reflections of coal in the diagrams are made according to the tables of the granulometric composition.

Table 1. Granulometric composition of the trench coal in the plant - entrance into the crusher

Size of sieve openings, mm	M%	$\Sigma M\% \downarrow$	$\Sigma M\% \uparrow$
800	0	0	100
-800+500	5	5	100
-500+200	15	20	95
-200+100	20	40	80
-100+30	40	80	60
-30+0	20	100	20
Sum	100		

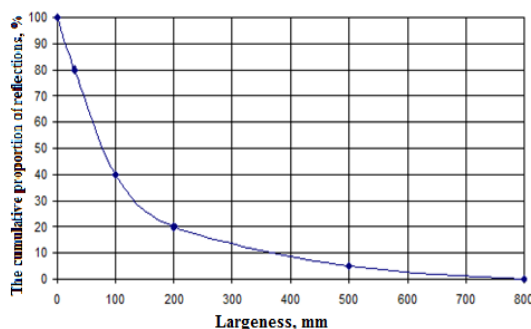

Fig. 5. Granulometric composition of coal at the inlet of a crushing plant, $F_{80} = 200\ 000\ \mu\text{m}$

Table 2. Granulometric composition of trench coal in the plant – output of the crusher

Size of the sieve openings, mm	M%	$\Sigma M\% \downarrow$	$\Sigma M\% \uparrow$
100	0	0	100
-100+60	5	5	100
-60+25	15	20	95
-25+10	30	50	80
-10+5	20	70	50
-5+0	30	100	30
Sum	100		

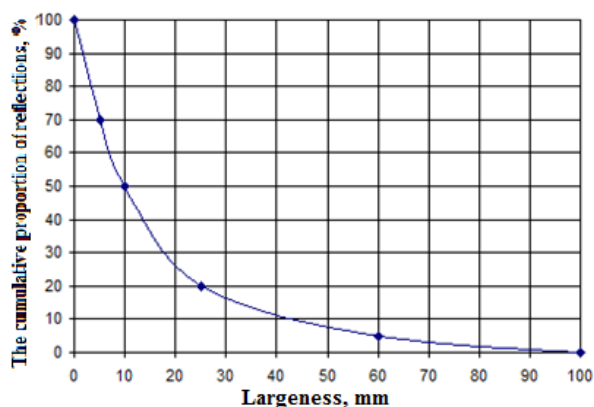

Fig.6. Granulometric composition of coal at the outlet of the crushing plant, cumulative reflection curve, $P_{80} = 25\ 000\ \mu\text{m}$

CONCLUSION

Coal crushing is a daily technological operation that is present in almost all coal mines. The task is to ensure the size of the pieces according to market requirements (thermal power plants, heating plants, consumer goods ...).

Hammer crusher with rollers type KDV 1137, in the process of grinding lignite, is one of the most optimal technical solutions for realization of technological scheme of coal processing, considering its technological capabilities. The hammer crusher during lignite processing enables its crushing according to the requirements of users of the crushed coal, e.g., thermal power plants, with different structure of granulometric composition, which in today's business conditions is a very important factor for profitability and the success of operations of coal processing plants. This type of crusher directly drives the working element (hammer rotor) in contact with the material, which, due to its high velocity and rotation mode, creates large centrifugal force acting in a vertical direction. As for the wear-out of the parts that come in contact with the material (hammer), their durability is acceptable, not only because of the use of the proper material, but also because of the possibility that they will be rotated and used on the other side after the wear-out of one side. Changing the variant of work, i.e., changing

the size of the gap between the working elements of the hammer crusher in grinding coal, is a relatively simple and quick procedure, taking into account its technical and structural characteristics, which also enables successful optimization of the grinding process.

REFERENCES

- [1] Huangping, Z., Lan, H., Yang, S., Research of manufactory technology for the hammer of single roll crusher, Equipment manufacturing technology and automation, pts 1-3 Book Series: Advanced Materials Research, 317-319, pp. 162-168, 2011.
- [2] Zhao, X., Zhou, H., Rong, S., et al. Research on the New Combined Type Crusher Hammer, Materials science, civil engineering and architecture science, mechanical engineering and manufacturing technology, pts 1 and 2 Book Series: Applied Mechanics and Material, 488-489, pp. 1160-1165, 2014.
- [3] Kostović, N., Priprema uglja u Srbiji Monografija: Stanje i perspektive pripreme mineralnih sirovina u Srbiji. Inženjerska akademija Srbije, Beograd, 2011.
- [4] Trajković, S., Lutovac, S., Tokalić, R., Knežević, D., Deušić, S., Ignjatović, D. Drobilice za ugalj - vrste, izbor, tržište i primena, Zbornik radova IV Međunarodna konferencija Ugalj 2008, Jugoslovenski komitet za površinsku eksploataciju 2008, „Janko Stajčić“, Lazarevac, 2008.
- [5] Lin, J., H. P., He, F., Longevity Study of the Head of Hammer Crusher, Equipment manufacturing technology and automation, PTS 1-3 Book Series: Advanced Materials Research, 317-319, pp. 8-20, 2011.
- [6] Magdalinović, N., Usitnjavanje i klasiranje mineralnih sirovina, Nauka, Beograd, 1991.
- [7] Luz, J. M., Bonilla M., Antonio L., J., New wear solution for hammers in clinker and limestone crushers, ZKG International, 64, 10, pp. 20-22, 2011.
- [8] Yang, J. H., Fang, H. Y., Luo, M., Load and wear experiments on the impact hammer of a vertical shaft impact crusher, 4th global conference on materials science and engineering (CMSE 2015) Book Series: IOP Conference Series-Materials Science and Engineering, 103, Article Number: 012041 Published: 2015

SMART AND NETWORKED VILLAGES - INFORMATION SYSTEM FOR RURAL DEVELOPMENT

Krešimir Lacković¹, Milan Ivanović²

¹ University of North, Centre Koprivnica, Croatia

² Panon – think tank for strategic studies, Osijek, Croatia

e-mail: kresimir.lackovic@unin.hr

Abstract: The aim of this paper is to contribute to the setting of an information model for the development of smart villages in the Republic of Croatia with special reference to villages in five counties of Eastern Croatia. It considers (a) EU rural development policies (2014-2020), as well as broadband networks in EU countries, especially in the new EU Member States, and (b) the concept and policies applied in these sectors in the Republic of Croatia, especially within the Slavonia program. The results of the project "Slavonian Network - Development of Broadband Access in Eastern Croatia" are presented. The "Slavonian Network" project was launched in 2012, and the Panon Institute for Strategic Studies proposed (in published papers from 2013 to 2017) broadband development models with intensive involvement of local communities in terms of social and economic development of Slavonia. Based on the results of these analyzes, the concept of the information system "Slavonian smart and networked village" was proposed.

Key words: Territorial Development, Rural Innovation, Rural Services, Sustainability, Rural-Urban Linkages

INTRODUCTION

The Common Agricultural Policy (CAP) since the founding of the EEC and the Treaties of Rome (in 1957) has been one of the most important areas of activity of the institutions of the European Union, and rural development has subsequently been designated as the second pillar of the CAP. The objectives of this policy are: to promote the competitiveness of agriculture, to ensure the sustainable management of natural resources and climate change, and to achieve balanced territorial development in rural areas, including job creation and conservation. A new approach to rural development - dubbed 'smart villages' - appears in the Communication from the European Commission (EC) on the future of food and agriculture in November 2017 [1] with all elements of economic policy - from technology, communications, demographics, information systems and public relations to ecology and climate change. For complex consider of this topic more space/pages are needed to than is available here - therefore, the following considerations will only outline important factors - with reference to published papers explaining the details.

SMART VILLAGES AND EU RURAL DEVELOPMENT POLICY

CAP implementation for the period 2014 - 2020

The basic regulations of the new CAP were published in December 2013. Subsequently, the EC drafted the delegated and implementing acts that were necessary to introduce the envisaged measures. During 2014, Member States had to make key decisions in view of the diversity of the way the new direct payments system is implemented and the space available for manoeuvre. All but one Member State (Germany) made use of the option of coupled payments at very different rates: eight decided to apply a redistribution of payments, while 15 Member States applied the small farmer's regime. When it came to green payment, five Member States gave farmers the opportunity to fulfil some of their obligations by applying the same practice. In addition, the choice of areas of ecological importance varies greatly within the EU. In addition, 15 countries have transferred amounts between the two pillars: for the whole period, the net amount of transfer between the two pillars, i.e. from the first pillar to the second, was approximately four billion €. For the second pillar, between December 2014 and December 2015, the EC approved all 118 rural development programs developed by 28 Member States. Twenty Member States have decided to implement only one national program and eight have opted for more than one program - in order to better take into account geographical or administrative structures. [2] Rural EU policy, now as a Smart Village macro project, covers almost all elements of

economic policy - from technology, communications, demographics, information systems and public relations to ecology and climate change – so far more space/pages are required to consider this topic than is available here. Therefore, the following considerations will only outline important factors - with reference to published papers explaining the details.

In April 2017, the EC unveiled initiative for developing smart villages in the EU with the aim of achieving synergies with traditional agriculture, the Internet, local wireless networks and innovation, and through smart specialization to enable the development of new business models. The initiative also seeks to counteract negative demographic trends in rural areas. Public policies such as circular economy, energy union and digital economy need to achieve a EU energy transition to a low carbon society at reasonable cost to economy and greater citizen involvement in decision-making process in order to maximize social profit. Public sector policy-making requires coordination and collaboration of multiple sectors such as energy, transport, agriculture, economy and spatial planning. Development strategies, as a key document with policy objectives, must contain action plans for each sector in order to optimally achieve the policy objectives adopted. Action plans should take into account regional and local specificities, strengthen the planning, financing and implementation of activities, and encourage involvement in EU initiatives such as the Smart Villages [3].

The Smart Villages concept has brought renewed attention to the development needs and natural potential of rural areas and to a much greater focus on empowering communities at the local level for rural areas to survive and thrive in the coming decades. But at the same time, it signalled the need to strengthen the processes in which local communities take an active role in shaping their own futures. The EU Smart Village Initiative seeks to achieve the synergy of traditional agriculture, the Internet, local wireless networks and innovation, and through smart specialization, enable the development of new business models. The initiative also seeks to counteract negative demographic trends in rural areas. The initiative came to life with the adoption of the EU Action Plan for EC Smart Villages, defined as rural communities based on existing strengths, available resources and the development of new opportunities, i.e. communities where traditional and new networks and services are enhanced by digital and telecommunications technologies, innovation and better use of knowledge. The pilot project "Smart Villages" is being implemented in nine countries of the EU, including Slovenia, which carries out activities in the three municipalities. *"Smart villages are about different policies working together to find better, smarter ways to promote holistic rural development. It is about using existing and new technologies and social innovation to add value to the lives of our citizens. It's about giving the village the tools to meet their own challenges, and at the same time contributing to the greater challenges facing society as a whole."* [3] Therefore, concept of smart villages is one of solutions to prevent its dying out. Croatia is only just beginning in the concept of Smart villages, and the Croatian village is, more than ever, affected by emigration and depopulation today [4-14].

The definition of smart villages

Smart Villages are communities in rural areas that use innovative solutions to improve their resilience, building on local strengths and opportunities. They rely on a participatory approach to develop and implement their strategy to improve their economic, social and/or environmental conditions, in particular by mobilising solutions offered by digital technologies. Smart Villages benefit from cooperation and alliances with other communities and actors in rural and urban areas. The initiation and the implementation of Smart Village strategies may build on existing initiatives and can be funded by a variety of public and private sources [15].

European Network for Rural Development

The European Rural Development Network has been engaged in a 'smart village' for the third year, focusing on the production of materials that help interested rural stakeholders. Management structures should make materials the most of in rural areas. The aim of developing these materials is to support the concept of 'Smart Village' in the current programming period and in future Common Agronomic Policies. The "smart village" advice on this network recommended that Member States take the following steps when designing support for smart villages in the future CAP [3]:

1. Recognize the needs of rural communities that smart villages can address;

2. Map the existing policy support framework to identify opportunities and disadvantages;
3. Develop a targeted package of interventions that will provide rural communities with an initial idea for change to its sustainable scope.

It is useful to point out here that the scope of planned support for a 'smart village' in Finland is very broad and inclusive - to reflect the very diverse needs of villages in different parts of the country; there is no intention to develop a general national strategy. The aim is to be able to respond quickly and flexibly to the needs expressed by local communities in the following fields [16]:

- Economic investments and actions for business development of new value chains and local economic clusters (agricultural and non-agricultural) based on local assets and (potential) areas of comparative advantage (bio economy, smart tourism destinations, etc.), smart transport and logistics solutions, smart local services and service chains and smart food chains, digitization and collaboration between businesses.
- Connectivity (broadband) and different models for businesses (for example, social entrepreneurship).
- Social innovation to ensure sustainable and good quality social and cultural services. Also, investing in skills for the future, supporting urban-rural connectivity and sustainable well-being: preventing segregation and inequality among people, improved integration of immigrants, a sense of community, living conditions, culture, security, improving rural knowledge as well as access to "hidden" rural knowledge community.
- Environment - innovation to improve resources creates efficiency, create local energy communities, reduce carbon footprint, and improve biodiversity, both protecting and valorising environmental assets. Encouraging municipal authorities, business representatives, local people, research institutes and experts to work together to design and adapt new cost-effective emission reduction solutions, especially in the context of transport and mobility, housing and food. Low carbon villages: a circular economy, sustainable food production and local food.

RURAL DEVELOPMENT AND SMART VILLAGES IN THE REPUBLIC OF CROATIA

The concept of 'Smart village' is a new opportunity for Croatia to change its current direction and way of implementing agricultural policy, i.e. - rural development, by incorporating modern technological trends of internet technologies, energy efficiency, ecological agriculture (green economy), rural tourism, etc. into rural areas. This is fully in line with the priority areas set in the National Development Strategy 2030 [17,18]. In this way (by applying the concept of 'smart village') it can more effectively influence the trend of emigration from rural areas and encourage the arrival of young people into the country-side, that is, stimulate a balanced regional development using their potentials better and launching their (joint) development projects themselves. It is important here - as Euro-advocate Davor Škrlec points out - *“that the concept is recognized by the executive in defining the next operational program in national legislation, but the involvement of regional and local authorities is also required. This should remove local obstacles and encourage the development of projects. The concept of smart villages must be among the major initiatives in the next programming period for the modernization and demographic renewal of our rural areas.”*[19] One of the basic infrastructure platforms for realizing the concept of 'smart villages' is broadband access - fiber networks for high-speed Internet. Therefore, in order to consider the possibility of implementing this concept of rural development in Slavonia and Baranja, it is important to point out the state of play in this sector - that is, to point out experiences in implementing the project "Slavonian Network".

"Slavonian Network" - a broadband project

Following adoption of the Broadband Development Strategy in the Republic of Croatia from 2012 to 2015, the Faculty of Electrical Engineering in Osijek (ETF), in February 2012, in cooperation with Croatian Network Agency (HAKOM), organized conference entitled "Development of telecommunications infrastructure – strengthening competitiveness and effective local self-government investment" which was also attended by the leaders of many municipalities, cities and five counties of the Slavonia-Baranja (SB) region. At the end of that year, the ETF launched project "Development of a Broadband Approach in the Five Counties of Slavonia and Baranja" [20-25]; (Fig. 1 and 2)

Interdisciplinary project team of 'Slavonian Network' - composed of doctors, masters and graduated engineers of telecommunications, informatics and accounting, geodesy, economics, sociology and law from ETF and Panon Institute for Strategic Studies, Osijek and companies Geoprem doo Osijek and "Sokol" d.o.o. Vinkovci - created concept of the 'Slavonian Network' project and began to research and develop individual modules of this project. The project "Slavonian Network" (total amount of € 21.5 million) received three positive reviews from the Ministry, and by publishing papers at scientific conferences and journals, team members tested hypotheses and/or promoted the project. In this way, an effort was also made to carry out part of the mobilization and training preparations for involvement of other experts and LSGs from the region in its implementation. Results of one of the first studies (2012) on structure of costs in construction of municipal infrastructure (water supply, sewage, public lighting, hot water pipeline) and public infrastructure (electrical underground network, gas pipeline) were published in the Proceedings of the conference GAS 2013. [23]; the share of earth-works (construction) costs in the construction of fiber optic infrastructure is around 70%, and conclusion of the study - that an integrated approach can achieve a significant reduction in investment costs for construction of broadband infrastructure - is a proposal aimed at accelerating the realization of the "Slavonian network" and reducing costs; It is necessary to install plastic pipes at every construction (and before the start of construction within the framework of the "Slavonian Network") at each construction of the local public infrastructure.

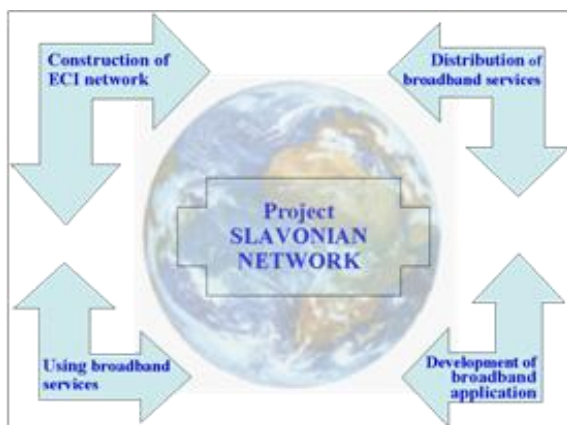

Fig. 1. "Slavonian Network" project [23]

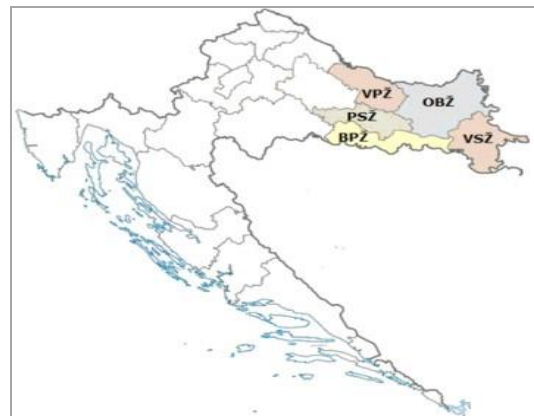

Fig. 2. Area of "Slavonian Network" [22]

However, this proposal - as well as several other organizational models (establishment of consortia, model of 'easement of rights' for electronic communications structure, model of concentration of available financial resources at the county level, and others) - unfortunately did not come to finalization - because in 2014 the project was transferred to level of the University, and all authors of the "Slavonian Network" project were excluded from further work on the project, and new team in the next five years did not realize the earlier proposals and are not initiate others models for implementation. He thus infamously finished the project, which was ranked 11th among the five hundred applications submitted to the Ministry's competition, and was the only broadband project and the only one covering more than one county (Fig. 2). Finally - it should be emphasized that the existing broadband network in the five counties of the Slavonian region is not adequate for the needs of contemporary development, neither in capacity nor in speed; for the most part, this is based on copper conductors or over the air network - making it difficult to access high-speed Internet, especially when multiple users are involved at the same time. This means that for the development of 'smart villages' it is necessary to speed up the construction of a broadband network and make up for the lost seven years.

Social cohesion and knowledge society a prerequisite for smart village's development

Experience from realization of this project has been discussed in several papers by Slavonian Network project team, from which it is important to state important issue of social cohesion - which is, otherwise, crucial for implementation of infrastructure project [26] - as the show Fig. 3 and Fig. 4.

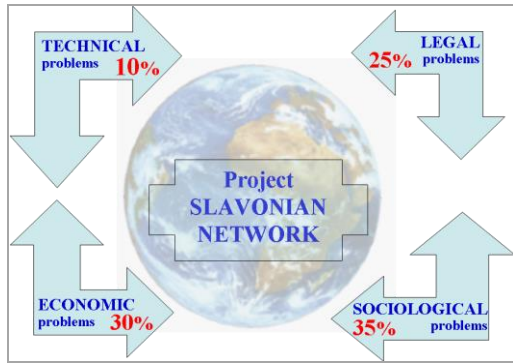

Fig. 3. Elements of social cohesion [26]

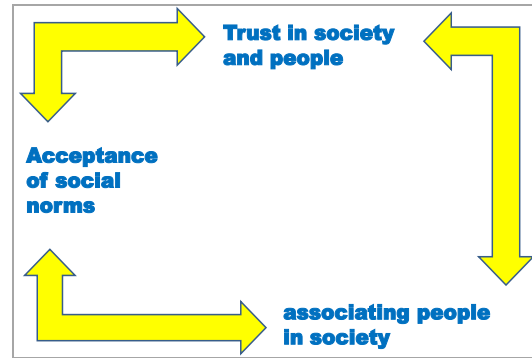

Fig. 4. Problems of "Slavonian Network" [23]

In addition to the above - for the implementation of the concept of 'smart villages', the issue of understanding and application of the concept of 'Knowledge society' in Croatia is also important - on which concept EU projects are based. The know-ledge society (Fig. 5.) is not yet a governing concept in Croatia and especially not in the element of 'lifelong learning', but also because of the fact that the practice is prevalent in which politicians of the 'general direction' make decisions often without effective public consultation, and without consulting independent experts.

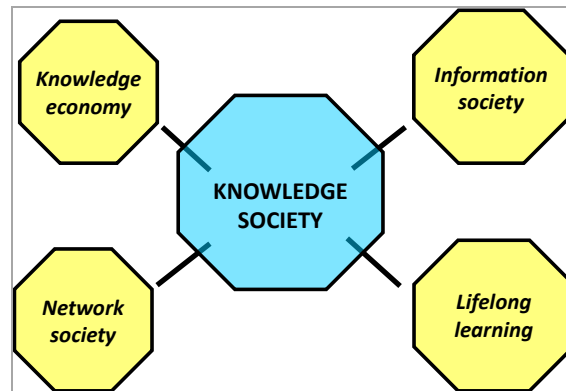

Fig. 5. Elements of the Knowledge society concept [27]

INFORMATION SYSTEM FOR DEVELOPMENT OF SMART VILLAGES

Information system includes people, data, processes and information technology, which are together in the function of collecting and processing the data on the basis of which information is stored. Information can thus also be viewed as the output of an information system, since it is created to support the work of the organization. [28] [29] Each information system consists of:

- Hardware - the physical part of the information system (computers, modems, network equipment ...);
- Software - an invisible part of the information system in the form of software solutions, algorithms that drive hardware;
- Life ware - all those who use the information system;
- Data ware - the way and methods of organizing databases and data warehouses;
- Net ware - communication and networking solutions that bring all the elements together;
- Org ware - organizational procedures and methods for connecting all the above elements into one.

Today are in use:

- Classic or transactional information systems,
- Decision support systems,
- Expert systems,
- Communication and collaboration systems.

Decision support systems and communication and collaboration systems are important for our consideration.

An insight into the existing supply of structured knowledge and the broadcasting of important information in areas relevant to 'smart villages' shows that there are hundreds of information systems that produce the necessary information for use in the development of local 'smart village' projects. For example, at the national level, authorities issue daily important information on rural development (from the Ministry of Agriculture, Ministry of Regional Development, Ministry of Finance and other ministries and several national agencies), as well as regional (and local) institutions and EU institutions and/or networks. In this innumerable amount of information, local stakeholders of 'smart village' will not be able to read or read all that information daily, let alone act on it. Therefore, when designing implementation of 'smart village' concept and structural modelled of implementation units should be undertaken, as well as the identification of information needs and the construction of an appropriate information system.

a) Smart Village implementation unit

Each village has its own specificities - natural resources, tradition and human capital, and 'smart village' development programs will be developed on these bases. This means that each village will have its own development program. However, many villages in the regional structure, by territorial and geographical features, will have a number of common elements on which to build their development programs. Therefore, it is advisable to propose the creation of so-called smart village concept implementation units - Fig. 6. - within which there would be one expert team for all villages in one implementation unit, in which, besides local experts (agronomists, etc.), there would be associate experts from surrounding cities (from related companies, associations, chambers, etc.) to ensure that all relevant areas of development are represented by a professional team structure.

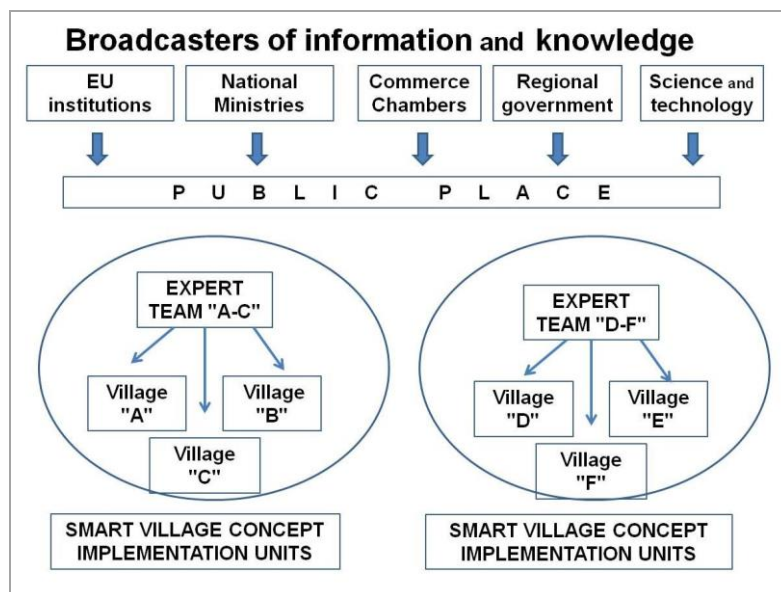

Fig. 6. Model of receiving, selecting and sharing information/knowledge through units for implementation of the smart village concept

b) Identifying information needs

The said expert team should determine the information needs (area, frequency, manner of distribution and distribution) of its design and establishment of programs and methods of work - which should be documented in a separate act.

c) Building an appropriate information system

IT literacy of the average expert (of any profile) in Croatia is today at a reasonably satisfactory level so that building or setting up an information system that would suit the needs of the expert team in each implementation unit of the 'smart village' would not be a particular problem - especially if a staff

member from a local software company involved in the process. After setting up the information flows set out in a separate act, the choice of hardware would be started - which should also not be a problem since the current supply of computer equipment in us is satisfactory. Software is also required to complete the 'smart village' implementation information system. It should be noted here that there are a number of ready-made applications (programs) on the Internet and networking applications that can be used for free (or at a small fee) - so it is not necessary to create special computer programs for this purpose. The education (training) of all stakeholders in the 'smart village' to use the selected program is also important element for the well-functioning information system of each unit implementation and each individual 'smart village'.

d) Public relations policy

At the end of these considerations, it is important to emphasize the need for transparency of the whole process and the importance of involving all stakeholders (experts, local government bodies and every household) in the implementation of this development project. That is why it is necessary to have a well-established and developed public relations model from the first step of setting up and implementing the 'smart village' concept. [30] This is important not only because of the mobilization of all stakeholders in the smart village on a joint development project - in order to optimally set up and implement the project, but it is also important in order to prevent potential corruption – it is also important to prevent potential corruption - which is not unknown in our region; even more - it domesticated.

CONCLUDING REMARKS

The EU's Common Agricultural Policy, and rural development as its second pillar, have been given a new dimension of action through the concept of 'smart villages'; In April 2017, the European Commission launched an initiative to develop "smart villages" in the EU with the aim of achieving synergies with traditional agriculture, the Internet, local wireless networks and innovation, and through smart specialization, enable the development of new business models.

- The Smart Villages pilot project is being implemented in nine EU countries - including Slovenia, but the Republic of Croatia is not included.
- The Croatian village is more than ever affected by emigration. Therefore, the concept of smart villages is one solution to prevent its dying out. The concept of 'smart village' is a new opportunity for Croatia to change its current direction and way of implementing agricultural policy, i.e. - rural development, by incorporating modern technological trends of internet technologies, energy efficiency, ecological agriculture (green economy), rural tourism, etc. into rural areas. . This is fully in line with the priority areas set out in the 2030 National Development Strategy.
- One of the cornerstones of successful implementation of the 'smart village' concept is the availability of broadband access. Although the Faculty of Electrical Engineering in Osijek initiated the project "Broadband Development in the Five Counties of Slavonia and Baranja" at the end of 2012, to date, this network in the five counties of the Slavonian region is not adequate either in capacity or in speed. This means that for the development of 'smart villages', it is necessary to speed up the construction of broadband and make up for the lost seven years.
- In addition to the above - for the implementation of the concept of 'smart village', the issue of understanding and applying the concept of 'Knowledge Society' in Croatia is also important - on which concept EU projects are based. Knowledge society is not yet a governing concept in our country, especially not in the element of 'lifelong learning', but also due to the fact that the practice is prevalent in which politicians of the 'general direction' make decisions, often without consulting independent experts.

After a framework analysis of the situation in the Slavonian region, a model of the so-called implementation unit of the "smart village" concept was proposed and basic frameworks for building (setting up) the "smart village" information system were proposed. In order for the whole process of setting up and implementing the concept of a smart village to be efficiently and quality implemented, it is important that the first step is to cultivate an objective public relation.

REFERENCES

- [1] EU Rural Review, No 26, 2018 ISSN 1831-5321
- [2] https://ec.europa.eu/commission/presscorner/detail/en/IP_15_6283
- [3] European Network for Rural Development - Rural Connections - The European Rural Development Magazine, spring/summer 2019, ISSN 2443-7379
- [4] Međunarodna konferencija: "Pametna sela – digitalno ruho tradicije" 2019. Osijek, HGK – Županijska komora Osijek
- [5] <https://ruralnirazvoj.hr/3-hrvatski-ruralni-parlament-koncept-pametnih-sela/>
- [6] Ivanović, M. - Pešo, I.; Vuković, S.: Obnova agro-proizvodnje na području prigradskog prstena grada Osijeka, ISBN 9536980-00-2 Albert^E, Osijek, 2000.
- [7] Ivanović, M.- Konstitucionalna ekonomija agrara EU predgovor knjizi Branka Hebranga „Poljoprivreda u Europskoj uniji” ISBN 953-6980-01-0; Albert^E, Osijek, 2005, str.I – III
- [8] Ivanović, M. - Ruralni razvitak – nova šansa koja se ne smije propustiti u grupa autora: Okvir za ruralni razvitak, ISBN 953–99364-1-1; Slap, Osijek, 2005.str. 13 - 28;
- [9] Ivanović, M.- Agro-poduzetništvo u procesima tranzicije, - Savremena poljoprivreda”, ISSN 0350 -1205; Novi Sad, Vol. 30, br. 3 – 4, 2006.str. 87 – 93
- [10] Ivanović, M. - Ekološka poljoprivreda i razvitak sela, u knjizi „Vodič kroz organsku proizvodnju” ISBN 953 –99364-2-X; Slap Osijek, 2007. str. 13 – 28
- [11] Ivanović, M.- Novi model sagledavanja ukupnog razvoja lokalnih područja predgovor knjizi Anke Mašek „Program ukupnog razvoja Općine Erdut“, Ekonomski fakultet, Osijek, 2007.
- [12] Ivanović, M. - Ruralni razvoj i procesi tranzicije - Slavonska poljoprivreda prema EU standardima ISBN 953-6032-501-1, Albert^E, Osijek, 2008.
- [13] Ivanović, M.; Požega Ž. - Ekonomski razvoj Slavonije i Baranje - prilozi za makro-ekonomsku analizu regionalnog razvoja u RH, 2nd International Conference „Vallis Aurea”, Požega, 3.9.2010. DAAAM International Viena, ISBN 978-953-98762-7-0; Proceedings, str. 475 - 486
- [14] Ivanović, M.: Subašić, R.; Trischler, R.; Križanović, K. - Development of fruit and vegetable processing industry in Slavonia and Baranja; the paradigm is needed 2nd International conference „Economy of Easter Croatia“, Osijek, May, 23-25, 2013; Proceedings, pp 54 – 64
- [15] Smart Villages - Pilot Project, Briefing note, Brussels, 21-22 February, 2019
https://enrd.ec.europa.eu/smart-and-competitive-rural-areas/smart-villages/smart-villages-portal_en
- [16] Smart Villages in Finland - ideas for designing support in the future CAP Strategic Plans, European Network for Rural Development, <https://enrd.ec.europa.eu/info@enrd.eu>
- [17] <https://www.hrvatska2030.hr/wp-content/uploads/2017/11/NRS2030.pdf>
- [18] Ministarstvo regionalnoga razvoja i fondova Europske unije - Stanje provedbe Sporazuma o partnerstvu i stanje izrade Nacionalne razvojne strategije, Zagreb, 27. 11. 2019.
- [19] Škrlec, Davor - Pametna sela za modernizaciju i demografsku obnovu naših ruralnih područja, <http://www.davor-skrlec.eu/>
- [20] Ambroš, F.; Ivanović, M.; Mesarić, D.- Izgradnja komunalne infrastrukture i razvoj optičke mreže na području Slavonije, 5th International Conference; PLIN 2013, Osijek, 2013. Proceedings, pp
- [21] Ivanović, M.; Ambroš, L.; Mesarić, V.- Establishing a Consortium - Way for Successful Implementation of Investment Projects" 3rd International scientific conference „Economy of Easter Croatia“, Osijek, May, 23-24, 2014; ISBN 978-953-253-106-0, Proceedings, pp 16 - 22
- [22] Ivanović, M.- Economic Interests and Social Problems in Realization of Broadband Network, In the book "Broadband Communications Networks - Recent Advances and Lessons from Practice"; A. Haidine, A. Aqqal (Ed), Open Source - InTech, 2018; ISBN 978-953-51-5810-3
- [23] Ivanović, M.; Ambroš, F.; Mesarić, D.- Models of investment in fiber optic networks and implementation of the "Slavonia network" project; 3rd International scientific conference „Economy of Easter Croatia“, Osijek, May, 23-24, 2014; ISBN 978-953-253-106-0, Proceedings, pp 4 – 16.

- [24]Ivanović, M.; Ambroš, F.: The Economic Impacts of Broadband Access Investment in The Croatia 5th International scientific conference „Economy of Easter Croatia“, Osijek, June, 1-3; 2015. ISSN 1848-9559, Proceedings, pp 49 – 60
- [25]Ivanović, M.; Ambroš, F. Mesarić, D.- Osnivanje službi za upravljanje lokalnim optičkim mrežama i njihovo održavanje na području Slavonije i Baranje 26. Znanstveni skup “ OTO '2017.; Osijek, 26.5. 2017. ISBN 978-953-6032-92-1; Proceedings, Elektrotehnički fakultet Osijek, pp 141–150
- [26]Ivanović. M.: Socijalna kohezija - temeljna odrednica razvoja, 1st International Conference „Vallis Aurea, Požega, 19.9.2008. ISBN 978-953-98762-7-0, Proceedings, pp 327 – 332
- [27]Ivanović, M. - Tri eseja o znanosti, ISBN 978-953-6032-55-6226, Elektrotehnički fakultet Osijek, 2009.
- [28]Whitten, L. J.; Bentley, D. L. - Systems Analysis and Design Methods, McGraw-Hill/Irwin, USA, 2007, pp 6
- [29]Lacković,K. - Public opinion as main factor of efficacy of public relations,“29th International Conference“ University of Maribor, Simpozium 24.-26.03.2010. Portorož.-str. 750-759.
- [30]Lacković,K., Horvat, T., Havaš,L.- Information System for Performance Evaluation in Team Sports, International Journal of Business Management and Technology, Vol. 2, January, 2018.

APPLICATION OF ORGANO-MINERAL AND MICROBIAL FERTILIZERS IN THE PROCESS OF RAISING RASPBERRIES

Srečko Curcic^{1*}, Stevan Babić², Sandra Milunović Koprivica¹,
Momcilo Vujčić¹, Aleksandar Laposavić³

¹Faculty of Technical Sciences in Čačak, University of Kragujevac, Čačak, Serbia,

²DOMIS TEAM, d.o.o, LUCANI,

³Institute of Fruit Growing in Čačak, University of Kragujevac, Čačak, Serbia

e-mail: srecko.curcic@ftn.kg.ac.rs, sandra.milunovic@ftn.kg.ac.rs,
momcilo.vujcic@ftn.kg.ac.rs

Abstract: The subject of this paper is the application of organic and microbiological fertilizers in the process of raising raspberries. Based on the conducted research, it can be concluded that the application of calcification on acidic soils, as well as the application of composted manure with microbial fertilizers, is obligatory when raising raspberry plantations as well as in plantations.

Key words: Organo-mineral and microbial fertilizers, Raising raspberries fuel

INTRODUCTION

The study of the influence of various organic and microbiological fertilizers on some agrochemical indicators of soil fertility, as well as the size of some biological criteria, was carried out in the process of raising raspberry planting on the test surface of "Mondi Lamex" doo Vrdila, KO Stupčevići, Municipality of Arilje. The trial was set on April 24, 2018 on an alluvial soil type.

The main object of the study was to determine the content of mineral nitrogen at the end of the vegetation, into a bank between rows outside the raspberry root zone, as well as within the raspberry root zone [1, 2]. The basic hypothesis from which we started is that the application of different organic, organo-mineral (burnt manure, italtolline and guanito) and microbial fertilizers based on effective microorganisms (EM OGROD, EM Naturalnie aktywny and EM bio) in the process of raising raspberry planting will show different influence on increase of mineral nitrogen content by raspberry growers. On the basis of preliminary research results, it can be concluded that the results of mineral nitrogen content in soil are a reliable indicator for the recommendation of fertilizer application, provided that certain prerequisites must be respected. Refer to the application of composted manure as well as the application of fertilizers which, in the rainy season, exert an influence on soil moisture retention and in the dry season they "retain" accumulated moisture (Organic soil cultivator "agro coal").

In this case, the average soil samples should be taken at the end of the vegetation, in the dry season and from the area of the plant root system. By creating preconditions related to the application of different organic, organo-mineral and microbiological fertilizers, in a certain period of the year, we can obtain reliable agrochemical indicators for determining the type and amount of fertilizer applied in the cultivation of different agricultural crops. This means that the data from laboratory analyses must be consistent with the conclusions of field experiments, which relate to different phenological observations and the magnitude of certain biological criteria. If the plant is highly responsive to applied organic and microbiological fertilizers, laboratory analysis data of average soil samples taken from the root zone at the end of the dry season must show low mineral nitrogen content in the soil, and vice versa, laboratory analysis data of average soil samples taken from the bank between rows and in the spread zone. The roots of plants without the use of organic and microbiological fertilizers must show a high content of mineral nitrogen. It is logical that this principle should apply not only to the content of mineral nitrogen in the soil, but also all other nutrients used by the root system of plants from the soil on which organic, organo-mineral and microbiological fertilizers were applied. The subject of these tests in 2018 included the impact of varying planting distances of frigo seedlings in line with the application of manure, organo-mineral and microbial fertilizers on the content of mineral nitrogen in the soil in the root zone. The basic hypothesis, we sent was that the planting distance of 40 cm frigo seedlings in a row, with two to three formed shoots of one frigo seedlings, with the use of

manure, organo-mineral and microbiological fertilizers in the year of planting, will have a positive influence on the height and the thickness of the growers, the plant's resistance to disease and stubble, that is, in the years of raspberry fertility, on the yield and quality of the fruits, as well as on the basic economic indicators - labor productivity, profitability and economy of raspberry production [3].

THE EXPERIMENT

Immediately before the opening of the furrows, we performed surface preparation of the land. The inter-row distance was 3 meters and, depending on the previously set plan of the experiment, the planting distance of the frigo seedlings in the row was 25 cm, 33 cm and 40 cm. 300 kg/ha of calcium carbonate were introduced and mixed into the open furrows. Before planting, the root of the frigo seedlings was immersed in 10% solution of EM OGROD [4].

Variants in the experiment:

1. Control, to the bank between the ranks.
2. Without fertilizer application, in the root zone.
3. Organo-mineral fertilizer italpollin 4: 4: 4 applied in the open furrows and in such widths 0.75 m on both sides of the row in the amount of application of 1600 kg/ha and guanito 6: 15: 3 in the amount of application of 800 kg/ha . Planting spacing of 33 cm.
4. Variant No.3. + EM Naturalnie aktywny, 10% solution.
5. Variant No.3. + EM bio, 10% solution.
6. Variant No.3. + Variant No.4. + Version
7. Pre-composted manure on the disposal pile with EM Naturalnie aktywny in the amount of 2 liters per 1 ton was introduced into the open furrows and strips of 0.75 m on both sides of the row. about 80 tons. Prior to planting frigo seedlings, composted manure with EM Naturalnie aktywny, 10% solution. Planting distance of frigo seedlings in a row 40 cm.
8. Organo-mineral fertilizer italpollin 4: 4: 4 applied at 1600 kg / ha and guanito 6: 15: 3 applied in the open furrows and in strips of 0.75 m width on both sides of the row. 800 kg/ha. With microbial fertilizer EM Naturalnie aktywny, 10% solution, excellent treatment of italpolline and guanite in open furrow and in strips on both sides of the row. Planting distance of 40 cm.



Fig. 1. Preparation of the land

Immediately after planting the frigo seedlings, the plants were watered daily, and later periodically in the extremely dry period of the year, which lasted about 40 days, with a total rainfall of only 9 mm. up to 36 degrees, which is unusual for the end of April and May. The application of microbiological fertilizers EM Naturalnie aktywny and EM Bio influenced the increased mineralization of organo-mineral fertilizers, which was manifested by acidification of the soil in the area of raspberry root, necrotation of root hairs, and thus slow growth, accompanied by pale green leaves on frigo seedlings. These symptoms were particularly noticeable on variants no. 3, No. 4, No. 5, No. 6 and No. 8. The most noticeable symptoms manifested through the stunting of plants are registered on variant no. 6 with application of EM Naturalnie aktywny and EM Bio. With the onset of the vinegar period for about two months, the observed symptoms on raspberry owners gradually waned; the leaves received an intense green color, with raspberry owners still lagging behind the variants without the use of italpolline and guanitis in open furrows. In 2018, in the broad agricultural practice, the same occurrence of chlorosis on the list was registered in the crop plantations fertilized at the end of March with a single application of nitrogen through the application of complex fertilizers NPK 16: 16:16 and

others. Based on these physiological observations, it can be concluded that the use of organo -mineral fertilizers in furrows should be excluded in raising long-standing plantations, and in wide agricultural practice, as soon as possible, the introduction of complex NPK fertilizers with more phosphorus and potassium should be performed, and then supplemented fertilization of agricultural crops with the required concentrations [5, 6].

At the beginning of the third decade of September, which corresponded to the end of the dry period (September 21, 2018), we took average soil samples for basic agrochemical analyses. Soil samples were taken at a depth of 0 - 25 cm in the bank between rows and on all variants in the experiment in the area of raspberry root at a distance of about 50 cm from the planted seedlings.



Fig. 2. Planted frigo seedlings

Table 1. Sample description

Lab. No.	Designation	Depth (cm)
1	0	0-25
2	0-1 in the root zone	0-25
3	2	0-25
4	3	0-25
5	4	0-25
6	5	0-25
7	7	0-25
8	8	0-25

Test results of soil samples Z-294/18

Table 2. Partial acidity – pH in 1 M KCl and active acidity – pH in the water

Lab. No.	pH	
	In KCl	In H ₂ O
1	5.39	6.25
2	5.53	6.29
3	6.22	7.02
4	5.03	6.02
5	4.87	5.87
6	5.15	6.20
7	4.38	5.61
8	4.33	5.45

Table 3. Mineral nitrogen content (N min)

Sample description	Lab. no.	% moisture	kgN/ha abs. dry
0	1	2.73	51.02
0-1 in the root zone	2	2.69	35.39
2	3	2.73	32.06
3	4	2.65	20.61
4	5	2.75	18.96
5	6	2.71	27.32
7	7	2.71	20.63
8	8	2.63	23.67

Table 4. The results of the influence of manure, organo-mineral and microbiological fertilizers on some agrochemical indicators of soil fertility

The variant number	Variant	Lab. No.	Depth (cm)	pH		pH in H ₂ O- pH in KCl	pH in KCl	Moisture %	kg N ha abs. dry
				KCl	H ₂ O				
1.	Control (Ø) - into a bank between rows	1	0 - 25	5.39	6.25	0.86		2.73	51.02
2.	Without fertilization, in the root zone	2	0 - 25	5.53	6.29	0.76	Var.2- Var.1 0.14	2.69	35.39
3.	Italpollina+ Guanito	3	0 - 25	6.22	7.02	0.80	Var.3- Var.2 0.69	2.73	32.06
4.	Italpollina+ Guanito+EM Naturalnie aktywny, in the root zone	4	0 - 25	5.03	6.02	0.99	Var.3- Var.4 1.19	2.65	20.61
5.	Variant no. 3.+EM bio	5	0 - 25	4.87	5.87	1.00	Var.3- Var.5 1.35	2.75	18.98
6.	Variant no. 3.+ variant no. 4.+ Variant no. 5	6	0 - 25	5.15	6.20	1.05	Var.3- Var.6 1.07	2.71	27.32
7.	Manure + EM Naturalnie aktywny (40 cm in a row)	7	0 - 25	4.38	5.61	1.23	Var.2- Var.7 0.70	2.71	20.63
8.	Variant no. 3+ EM Naturalnie aktywny (40 cm in a row)	8	0 - 25	4.33	5.46	1.13	Var.3- Var.8 1.89	2.63	23.67

On variant 2. The 2 pH value in KCl was 5.53. The highest pH value of the soil obtained on variant no. 3 with the use of italpolline and guanite was 6.22. With the application of microbiological

fertilizers EM Naturalnie aktywny and EM bio (Variant No. 4, No. 5, No. 6, No. 7 and No. 8), the soil acidity in the raspberry root zone increased. The greatest increase in soil acidity was achieved on variant no. 7 (pH KCl 4.38) and variant No.8 (pH KCl 4.33). Increasing the value of the difference between pH in H₂O and pH in KCl on variants using microbial fertilizers, compared to variant 3, without the application of these fertilizers, can be related to the influence of EM Naturalnie aktywny and EM Bio on the degradation of soil organic matter as well as organic matter from manure and organo-mineral fertilizers.

The high mineral nitrogen content in the soil was registered in the bank between the rows, outside the area of the raspberry root, and amounted to 51.02 kg/ha (variant No. 1). In the raspberry root zone, without fertilizer application, the mineral nitrogen content was 35.39 kg / ha (variant No.2). The highest moisture content in the air-dry samples was on the fertilizer variant itapollin + guanito + EM and was 2.75%. On the same fertilization variant, the content of mineral nitrogen in the soil was 18.98 kg / ha, which can be related to the influence of the applied organo - mineral fertilizers and microbiological fertilizer EM on the maximum increase in the amount of mineral nitrogen by raspberry owners. It is important to emphasize here the basic feature of itapolline and guanite to gradually release mineral nitrogen from the organic form, with minimal leaching of nitric nitrogen into deeper soil horizons. On variant 6, a slightly higher mineral nitrogen content of 27.32 kg / ha was registered compared to variant No.4 No.5 No.7 and No.8 resulting from the toxic effects of EM Naturalnie aktywny and EM Bio, applied with itapolline and guanite in open furrows before planting raspberries. The content of mineral nitrogen in the application of organo-mineral fertilizers and microbiological fertilizer EM Naturalnie aktywny amounted to 20.61 kg / ha (Option No. 4), which is in comparison with the content of mineral nitrogen with the application of organo-mineral fertilizers (Option No. 3). less by 11.45 kg / ha. Based on these results, it can be concluded that the use of microbial fertilizer EM Naturalnie aktywny had an effect on the increase in the amount of mineral nitrogen by raspberry growers. When using composted manure with EM Naturalnie aktywny in the process of extraction from the barn as well as its subsequent surface composting (Variant No. 7), the mineral nitrogen content was 20.63 kg/ha.

Quantitative indicators of the basic biological criteria of raspberry plants will be subsequently registered after the placement of the backrest for the planting system for raising the plantation, that is, after the end of the linking and pruning of lasers in the first year of raspberry genus [7].

CONCLUSION

Based on the conducted research, it can be concluded that the application of calcification on acid soils, as well as the application of composted manure with microbiological fertilizers, is obligatory when raising raspberry plantations as well as in plantations. The use of microbial fertilizers has the effect of increasing the utilization of organo - mineral fertilizers by plants. In relation to the amount of application of it alpolline and guanite, it is determined by the manufacturers of these fertilizers and their application should be adhered to within the given limits. In addition to basic chemical analyzes of soils necessary for determining the type and amount of fertilizer application, the obtained results of mineral nitrogen content in the soil indicate the necessity of applying manure, organo - mineral and microbiological fertilizers as the ultimate link in the system of increasing the reliability of data processing of the obtained results. The application of manure, organo-mineral and microbiological fertilizers, as well as the application of different planting distances of frigo seedlings in a row, exert a different influence on the quantitative characteristics of the height and thickness of raspberry growers, their uniformity in relation to the growth of plants and the number of mature seedlings formed from buds on root roots. The values of these biological standards represent the final stage of the tests conducted and they should relate the results obtained with the new method of application of fertilizers for raising raspberry plantings, in plantations and in other crops.

ACKNOWLEDGMENT

The research presented in this paper is partially funded RS Ministry of Education, Science and Technological Development, contract no. 451-03-68 / 2020-14 / 200132 whose implementer is the Faculty of Technical Sciences in Čačak - University of Kragujevac.

REFERENCES

- [1] Leposavic, A., Djurovic, D., Keserovic, Z., Popovic, B., Mitrovic, O., Miletic, N., Magazin, N. (2013): Evaluation of raspberry cultivars grown in the western Serbia region. Horticultural Science – Zahradnictvi, 40, 1: 1–7.
- [2] Leposavic, A., Jankovic, M., Djurovic, D., Veljkovic, B., Keserovic, Z., Popovic, B., Mitrovic, O. (2013): Fruit quality of red raspberry cultivars and selections grown in Western Serbia. Horticultural Science – Zahradnictvi, 40, 4: 154–161.
- [3] Curcic, S., Milunovic, S.: Logistic support for cogeneration plants with resources of communal systems, Proceedings of 28th International conference Energetika 2012, ISSN 0354-8651, Zlatibor, 27-30. 03. 2012, pp. 176-179.
- [4] Petrovic, S., Leposavic, A. (2011): Raspberry - new technologies for cultivation, protection and processing, Fruit Research Institute, Čačak, 1–225.
- [5] Curcic, S., Milunovic, S.: Management of transport biomass for energy production, Proceedings of 1st International Conference Economics and Management-Based on New Technologies, EMoNT 2011, Kladovo, Serbia, 2011, pp. 189-194, ISBN 978-86-6075-023-7, COBISS.SR-ID 188554764.
- [6] Curcic, S., Vujcic, M.: Environmental Protection Through Composting Processes, IX International Conference - Industrial Engineering and Environmental Protection (IIZS 2019), Proceedings, ISBN 978-86-7672-324-9, Zrenjanin, 3rd - 4th October 2019. Pp 304-310.
- [7] Petrovic, S., Leposavic, A., Jevremovic, D. (2017): Raspberry - The management, processing and marketing. Scientific Pomological Society of Serbia, Čačak, Serbia.

OPTIMIZATION OF A SIMULATION FOR THERMOELECTRIC GENERATORS AND THEIR APPLICATION IN WATER BOILER SYSTEMS WITH COMBUSTION CHAMBER

Cristian Chirita¹, Momir Tabakovic¹

¹University of Applied Sciences Technikum Wien, Department of Renewable Energy,
Vienna, Austria

e-mail: chiritacristian@gmail.com, momir.tabakovic@technikum-wien.at

Abstract: On the path to efficient and sustainable global energy consumption, waste heat recovery plays a vital role. In Austria, one of the sectors generating waste heat is the production of residential heating and hot water. For this purpose, nearly 30% of the total Austrian end-use energy demand is being consumed in water boiler systems with a combustion chamber, most of it in the form of fossil or biogenic fuels. This work investigates a possible use of thermoelectric (TE) generators to recover the waste heat produced in such systems. In this regard, a MATLAB Simulink model based on two Bismuth-Telluride thermoelectric generators is developed. The proposed configuration is a cascade setup with one generator (TEGW) attached to the external wall of the combustion chamber (temperature $\approx 350^{\circ}\text{C}$) and the second one (TEGH) installed on the output water circuit (temperature $50^{\circ}\text{C}\div 130^{\circ}\text{C}$), both of them being cooled by the feedwater (temperature $10^{\circ}\text{C}\div 20^{\circ}\text{C}$). The calculation model is optimized using experimental methods. The combustion chamber is replicated with the help of a 5-mm-thick steel plate attached to a 1500W electric cooking plate. The performance of three different Bismuth-Telluride TE generators is investigated, calculating the effective temperature on their sides. The losses caused by the improper thermic contact between surfaces are assessed and applied to the model in form of a correction factor. The electrical power output of the cascade system, as resulting from the calculation, is 9.32W, out of which TEGW produces 8.45W and TEGH produces 0.87W. Although the output of the proposed configuration is 10% higher than the one of a single module, it is not high enough to justify the additional costs and technical effort.

Key words: Seebeck, waste heat, water boiler, energy harvesting, MATLAB simulation

INTRODUCTION

Higher heating and cooling needs have determined an increase of the global energy consumption in 2018 at a rate that is nearly double the average rate of growth since 2010. Even though the share of renewables in the energy mix had a substantial growth, the demand for fossil fuels increased, while the progress in the field of energy efficiency stagnated or evolved at a slower pace [1]. One of the main priorities on the global path to decarbonization and energy efficiency improvement is to harvest and use the waste heat [2].

Waste heat is generated in several branches of the economy. While in the power generation sector the resulting residual heat is used in cogeneration plants for centralized heating, rather considerable amounts are produced during the industrial processes. In Austria, the industrial sector consumes almost 30% of the end use energy [3] out of which up to 60% - 70% is lost in form of waste heat [4]. Another third of the end energy consumption is used for residential heating and hot water provision with more than two-thirds of it being produced in boiler systems with a combustion chamber powered by fossil or biogenic fuels [3]. This process is associated with greenhouse gasses emission and generation of residual heat.

In order to improve the efficiency of these systems, part of the waste heat which is contained in the flue gas can be recovered using economizers, plate heat exchangers or waste heat boilers [5]. Nevertheless, a significant amount of energy is lost through the radiation and convection that appear on the external surfaces of the combustion chamber [6]. Considering the high temperatures that are associated with this process, we can safely assume that this wasted energy can be recovered using thermoelectric (TE) generators.

Although most of the TE generators available on the market have low efficiency, they have several other advantages that would make them ideal to be used in water boiler systems with a combustion chamber. Besides transforming directly, the thermal energy in electrical energy, they have no moving parts and no working fluids inside, which gives them a longer lifespan especially when working with constant heat sources. Furthermore, they have no scale effect, a fact that allows them to be used in very limited spaces (for example inside smaller domestic water boiler systems) [7].

The working principle of water boilers with a combustion chamber consists in using the heat produced during the fuel burning process to warm up a transportation medium. In the water tube boilers, the water is circulated through tubes surrounded by the product of the combustion (fire and hot gas). They have generally large capacities and are frequently used in power stations [8]. The shell tube boilers operate by circulating the fire and hot gas mixture through long steel tubes that are surrounded by water. Most of them have a reversal chamber to guide the heating medium from the furnace to the pass, which has a temperature of 350°C on its outer wall [9]. The radiant heat occurring on the exterior of the chamber or on the outer wall of the combustion chamber can be harvested using TE generators. The cooling can be ensured using the feedwater. The temperature of the flue gas in the boiler's exhaust chimney is 200°C and the temperature of the output water-steam mixture can increase to 140°C; therefore, using a TE generator to harvest the waste or radiant heat would be appropriate. Domestic water boilers are generally reduced in size and produce water at a temperature of 90°C. Their combustion chamber has, in most cases, a volume smaller than 0.5m³ [10]. In spite of this compact construction, it would still be possible to install a TE generator on the outer surface of the combustion chamber.

The primary objective of this work is to investigate what amount of electrical energy can be generated using two Bismuth-Telluride TE generators in a cascade installation setup to harvest the waste heat in a water boiler system with a combustion chamber. The maximum electric power output is calculated with help of a MATLAB Simulink model, which is optimized using data obtained through experimental means.

The first part of the paper is dedicated to the calculation model that is used by the simulation. The existing studies on thermoelectricity and TE generator applications are reviewed, and a MATLAB Simulink model to evaluate the electrical power output based on the calculation of the effective temperature difference on the sides of the two TE modules is developed. The installation and functioning of TEGW is replicated experimentally. After determining the influence of thermal contact between surfaces on the electrical power output of the module, a correction factor for thermal contact is applied to the model used in the simulation. The electrical power output of the system is calculated using the optimized simulation.

REVIEW OF EXISTING TE GENERATOR APPLICATIONS

TE generator modelling

A thermoelectric generator consists of a certain number of thermocouples that are connected electrically in series and thermally in parallel and which use the Seebeck effect to transform the temperature difference on the sides of their thermocouples into electrical power [11].

Although there are several classes of materials like chalcogenides, silicides, skutterudites, Zintl, clathrates, Heusler, oxides, organics and composites that can be used for the construction of TE generators and that respond to the challenges of sustainable exploitation [12], the Bismuth-Telluride modules have the most convenient price and the widest spread on the market. They have working temperatures of 200°C to 260°C continuously and 380°C intermittently [13]. For the above-named reasons, they were chosen for the purpose of this work.

The TE generator can be modelled by studying its one-dimensional thermoelectric model under constant heat transfer [14] or by using the finite volume method applied to the equations of the thermoelectricity [15]. In some cases [16, 17, 18] Simulink models of the TE generators at their maximum power point (MPP) have been developed. Some of them [17] include the influence of the thermal resistance of the materials used in the TE generator, while other ones focus on tracking the point of MPP [18]. It was observed that the chosen thermoelectric material has a considerable impact on the performance of the TE generators, with the Bismuth Telluride modules having higher output power [19]. The applied temperature, heat rate and the thermal cycling influence, as well, the generator's performance. Faster heating times and thermal cycling increase the module's internal resistance and reduce the figure of merit [20].

TE generators in heat recovery

The use of TE generators for recovering waste heat has been the object of numerous studies. Experiments or simulations where the source of heat was the flue gas of stoves or the radiant heat of the combustion chambers have been extensively conducted and presented.

Champier et al. [21] and Tabakovic [22] studied the implementation of TE generators in multifunction biomass stoves and the optimization of their performance. The initial configuration delivered 7.6W of electrical power [21], while the optimized one managed to increase the output to 8.4W. The main factors that influenced the system's performance were the thermal insulation, uniform pressure on the module and the position of the flame used as heat source [22].

Sornek et al. [23] have investigated the power output of three TE generators installed on a typical wood-fired stove, two of them on the burning chamber's external surface and the third one on the flue gas channel. None of the three modules produced more than 41.7% of their nominal power, the identified causes being the non-homogeneous distribution of temperature on the generator's surface, the design of the flue gas channel, and the lower than expected temperature of the burning chamber's external wall.

Shen et al. [24] proposed a cascaded installation setup. Using three TE generators with different working temperatures, installed on a system with burning chamber, they obtained a maximal electrical power output of 283 W and an efficiency 5.92 % higher than the one of a single generator.

These results indicate that a cascade installation on a water boiler system with a combustion chamber is worthy of investigation.

SIMULATION OF THE CASCADE SYSTEM

A MATLAB Simulink model has been developed to investigate the performance of two Bismuth-Telluride TE generators installed in a water boiler system with combustion chamber. The proposed cascade configuration consists in one TE module (TEGW) that is attached to the external wall of the burning chamber and is cooled by the feedwater, and a second one (TEGH), which is installed between two heat exchangers (water cooling blocks) connected to the output and feed water systems. The values used for the temperatures of the feed and output water and of the burning chamber's wall, were determined, after studying the existing technical literature, to be: $T_{wall} = 125\div350^{\circ}\text{C}$; $T_{feedwater} = 1^{\circ}\text{C}$; $T_{outwater} = 50\div130^{\circ}\text{C}$. The modules used to build the simulation are TEG2-40-40-19/200 produced by EURECA Messtechnik GmbH.

Mathematical model

As highlighted in literature, the effective temperature difference on the thermocouples of the TE generator is affected by the thermal resistance of the elements (ceramic wafers, soldering) placed between the heat source and the thermocouple.

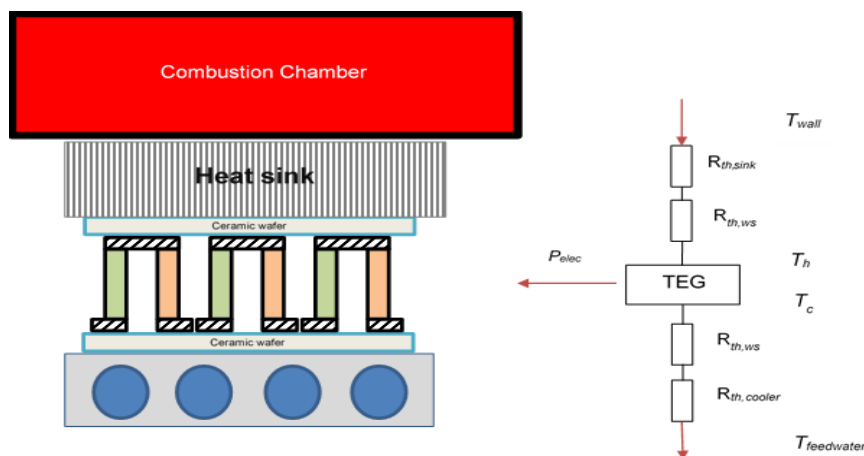

Fig. 1. TEGW module (left) and its thermal resistance model (right)

Fig. 1 presents the installation of TEGW (left) and its corresponding 1-D thermal resistance model (right). The relationship between ΔT and the temperature applied to the system $\Delta T_{syst} = T_{wall} - T_{feedwater}$ can be determined by writing the energy conservation equations. Cheng [14] has established that the effective temperature difference ΔT is influenced by the thermal resistances $R_{th,h}$, $R_{th,c}$ and by the internal electrical resistance R . For TEGW at the maximum power point (MPP) this can be calculated as:

$$\Delta T = \frac{\Delta T_{syst}}{1 + R_{th,c}k_{th} + R_{th,h}k_{th} + \alpha^2 \frac{(R_{th,c}T_{wall} + R_{th,h}T_{feedwater})}{2R}} \quad (1)$$

The thermal resistances $R_{th,h}$ and $R_{th,c}$ are calculated using the thermal conductivities of the ceramic wafers λ_{ceram} (25W/m K), of the soldering λ_{solder} , of the heatsink λ_{sink} and of the water cooler λ_{cooler} (all of them made out of aluminium with $\lambda_{Al} = 237$ W/m K) with the below equations:

$$\begin{cases} R_{th,h} = \frac{l_{sink}}{\lambda_{sink}S} + \frac{l_{cer}}{\lambda_{ceram}S} + \frac{l_{sol}}{\lambda_{solder}S} \\ R_{th,c} = \frac{l_{sol}}{\lambda_{solder}S} + \frac{l_{cer}}{\lambda_{ceram}S} + \frac{l_{cool}}{\lambda_{cooler}S} \end{cases} \quad (2)$$

where l_{cer} (1mm) and l_{sol} (0.7mm) represent the thickness of the ceramic and of the soldering layers, l_{sink} (10mm) is the height of the heat sink, l_{cool} (5mm) is the distance between the exterior surface of the cooler and the inner channels and S (1600mm²) is the surface of the transfer area.

The Seebeck coefficient α , inner resistance R and thermal conductivity k_{th} were calculated according to the manufacturer's instructions using approximated values for T_c and T_h . The approximation for T_h has been determined experimentally, analysing the loss of temperature from the heat source to the upper surface of the heat sink. Using MATLAB interpolation, the following 4th degree polynomial function was determined:

$$loss(x) = (-1.0439e-10)x^4 + (8.5851e-08)x^3 + (-2.8168e-05)x^2 + 0.0040039x + 0.083299$$

where:

$$x = T_{wall} \text{ and } T_h = T_{wall} (1 - loss(x)).$$

The correction factor used to approximate the value of T_c was determined as well experimentally, analysing the gain of temperature between the feedwater temperature $T_{feedwater}$ and the temperature of the outer side of the block cooler through which this is circulated. The dependence is linear in this case and can be written as:

$$T_c = 1.53 \cdot T_{feedwater}$$

A similar model was used to calculate the effective temperature difference for TEGH. Same as above, approximated values are used for T_c and T_h . The drop of temperature between the produced hot water and the outer surface of the heat exchanger was approximated using the following 2nd degree polynomial function:

$$loss(x) = (-7.3696e-05)x^2 + 0.0071351x - 0.028488$$

where:

$$x = T_{outwater} \text{ and } T_h = T_{outwater} (1 - loss(x)).$$

For T_c , the same correction factor as for TEGW has been used.

Using the calculated effective ΔT and the internal electrical resistance R provided by the manufacturer, the open circuit voltage V_{oc} , matched load current I , matched load output voltage V_{teg} and matched load maximum power W_{max} are calculated using the following equations:

$$V_{oc} = \alpha \cdot \Delta T \quad (3)$$

$$I = \frac{\alpha \Delta T}{2R} \quad (4)$$

$$W_{max} = \frac{(\alpha \Delta T)^2}{4R} \quad (5)$$

$$V_{teg} = IR \quad (6)$$

For all the above calculations, it is considered that the TE generator works at its MPP and consequently the load resistance R_L matches the internal electrical resistance R . The maximum efficiency of the power generation is:

$$\eta_{max} = \frac{\Delta T (\sqrt{Z\bar{T}} + 1 - 1)}{T_H \sqrt{Z\bar{T}} + 1 + T_C} \quad (7)$$

where the figure of merit Z is calculated as:

$$Z = \frac{\alpha^2}{Rk_{th}} \quad (8)$$

MATLAB Simulink model

The simulation was developed to operate in two modes: continuous and discrete. In the discrete mode, the user can set the temperatures of the outside wall of the burning chamber, the feed water and the output water. In the continuous mode, the user can set only the temperature for the feed water temperature, while the simulation will generate the all other ones. The total output electrical power is calculated algebraically by adding directly the values obtained from each module without taking into consideration the corresponding electrical circuit to connect the two modules and the power losses that might occur.

Cascade system electrical power output

First, the results of the simulation model were verified against the data provided by the manufacturer. Using the simulation in discrete mode for the following values: $T_{wall} = 240^\circ\text{C}$, $T_{feedwater} = 20^\circ\text{C}$ and $T_{outwater} = 130^\circ\text{C}$, it was calculated that the effective temperature difference for the TEGW module is 201.7°C , while the one for the TEGH module is 102.3°C . The open circuit voltage of TEGW was calculated to be 10.28V , while the one given in the datasheet is 10.28V . The calculated matched load current was 2.55A , while the one in the datasheet is 7.0A . Consequently, the calculated maximum power (13.12W) was lower than the one of the manufacturer (19W). A possible cause for this is that the information in the datasheet is provided for a given temperature difference without specifying the values of T_h and T_c . Using a series of computations in which ΔT was kept constant at 200°C , and T_h and T_c temperatures have been increased, it has been observed what was pointed out in the datasheet, namely that the electrical power output decreases with the increase of the mean temperature.

Considering the temperatures specific to a boiler system with a combustion chamber ($T_{wall} = 350^\circ\text{C}$, $T_{feedwater} = 20^\circ\text{C}$ and $T_{outwater} = 90^\circ\text{C}$), it was calculated that the electrical power output of the two TE generators in cascade setup is 23.52W , with TEGW producing 21.75W and TEGH 1.77W . This represents an increase of 8.4% compared to the output of a single TE generator.

EXPERIMENT RESULTS AND MODEL OPTIMIZATION

An experiment was carried out to assess the performance of the TE modules in conditions similar to the ones encountered in a water boiler system. The temperature of the combustion chamber's wall was simulated using a cooking plate with the nominal power of 1500W as heat source and a 5-mm thick steel

plate. For cold and hot water routing, a system of copper pipes, rubber hoses and stainless-steel valves has been used. Both cold and hot water were supplied on continuous flow from a tap. The heat transfer from and to the TE modules was done using three aluminium blocks of appropriate size. Two types of insulating material have been used: HeatStop Insulation tape (3mm thick, 50mm wide and effective for temperatures up to 1000°C) and Lih Feng Jiing industrial-grade fibreglass insulation mat (10mm thick maximum working temperature 650°C). The module's electrical wires have been protected using 0.5mm fibreglass silicone insulating sleeving, while all the other parts and components of the system that were exposed to heat were protected using Heat Shield Wrap Tape.

The performance of three TE modules has been investigated:

- Thermonamic TELBP1-12656-0.45 - Lead Tin Tellurium and Bismuth Tellurium module with a maximum matched load power of 21.7W and a maximum working temperature of 360°C;
- Eureka TEG2-40-40-19/200 - Bismuth Telluride module with a maximum matched load power of 19W and a maximum working temperature of 200°C;
- SP184827145 SA - Bismuth Telluride module with an estimated output power of 3.6W and a maximum working temperature of 150°C.

The TELBP1-12656-0.45 was the first tested module. Three testing configurations have been investigated: at first using HeatStop insulation tape and no thermal grease, then using fibreglass insulation and no thermal grease and finally using with fibreglass insulation and thermal grease.

It has been observed that that the fibreglass mat provided a better insulation due to its continuous structure. For lower temperature differences, the values of the output voltage in the three tries were quite close to the each other and they corresponded to the ones in the datasheet, but with the increase of the temperature, they deviated in a considerable degree, being lower than expected. It was observed as well that for the same effective temperature difference, the voltage in the warmup phase was superior to the one in the cooling down phase.

The second tested module was TEG2-40-40-19/200. This has been tested using fibreglass mat as insulation and without thermal grease. The measured open circuit voltage is presented in Fig. 2 (left).

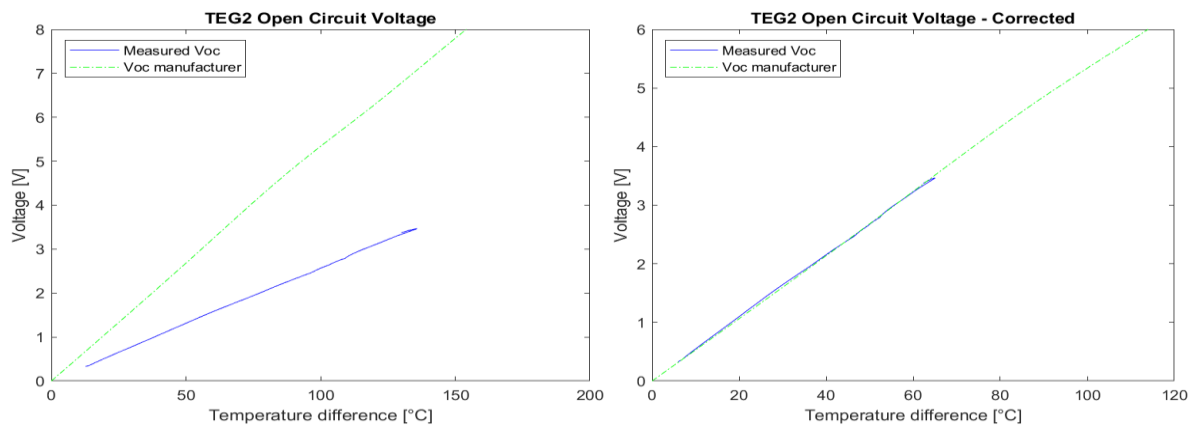

Fig. 2. TEG2 – open circuit voltage for $x_{contact}=0$ (left) and $x_{contact}=0.27$ (right)

It can be observed that the measured voltage was lower than the simulated one (manufacturer) and the deviation increased with the temperature difference. As highlighted by several TE module manufacturers [25], the voltage loss can be caused by the imperfect contact between surfaces. Therefore, it has become necessary to amend the calculation model to include the thermal resistance generated by the contact surface. This has been added as the factor $x_{contact}/\lambda_{Al}S$ to both $R_{th,h}$ and $R_{th,c}$ calculated in equation 2, where $x_{contact}$ is a dimensionless correction factor for thermal contact, which was determined using the experimental data. For this testing configuration, $x_{contact}$ has been determined to be 0.27. The measured open circuit voltage and the recalculated effective temperature difference are displayed in Fig. 2 right.

The influence of the thermal contact has been noticed as well while testing the third TE module, SP 18482715 SA. On the first try, after applying the above-determined thermal correction factor $x_{contact} = 0.27$, it was observed that the values of the measured open circuit voltage corresponded to the ones provided by the manufacturer. A second try was carried out using thermal grease. Without applying the

thermal contact factor, the measured open circuit voltage was closer to the one provided by the manufacturer (Fig. 3). The correction factor for thermal contact could consequently be reduced to 0.1. The simulation has been optimized systematic using the determined thermal contact correction factors. It can be considered that for $x_{contact}=0.27$, the calculated electrical power output is the minimum that a cascade system could generate, while the maximum possible output is generated when $x_{contact}=0$. During the experiment, once thermal grease has been used on both sides of the TE module, the correction factor was reduced to 0.1.

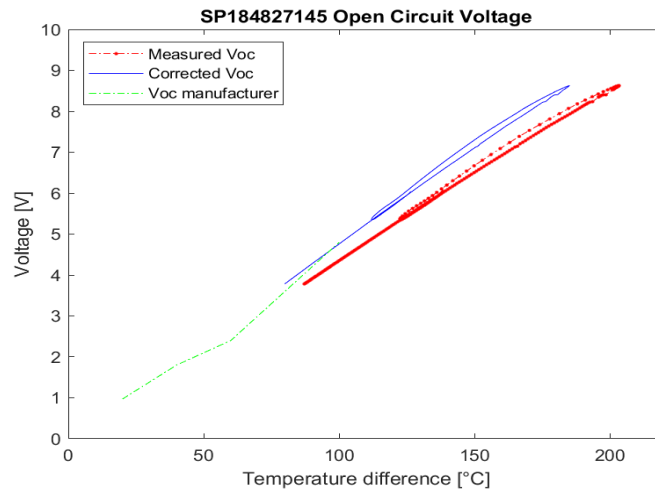

Fig. 3. SP184827145– open circuit voltage for $x_{contact}=0.1$

A comparison between the calculated electrical power outputs of the proposed cascade system in these three cases is presented in Table 1.

Table 1. Comparison electrical power output ideal case vs. optimization

	Ideal	1st Optimization	2nd Optimization
Thermal correction factor	0.0	0.27	0.1
Cascade system electrical power output	23.52W	3.52W	9.32W
TEGW electrical power output	21.75W	3.14W	8.45W
TEGW contribution to total output	92.5%	89.2%	90.7%
TEGH electrical power output	1.77W	0.38W	0.87W
TEGH contribution to total output	7.5%	10.8%	9.3%
Electrical power gain vs. single TEG	8.1%	12.1%	10.3%

The electrical power output has been measured only for the SP 18482715 SA module, since this had the highest open circuit voltage output on the previous test. This has been done by measuring the current and voltage in the electrical circuit presented in Fig. 4 (left). The maximum measured electrical power was 6.91W and was generated at an effective temperature difference of $\Delta T=185^{\circ}\text{C}$ (Fig. 4 right).

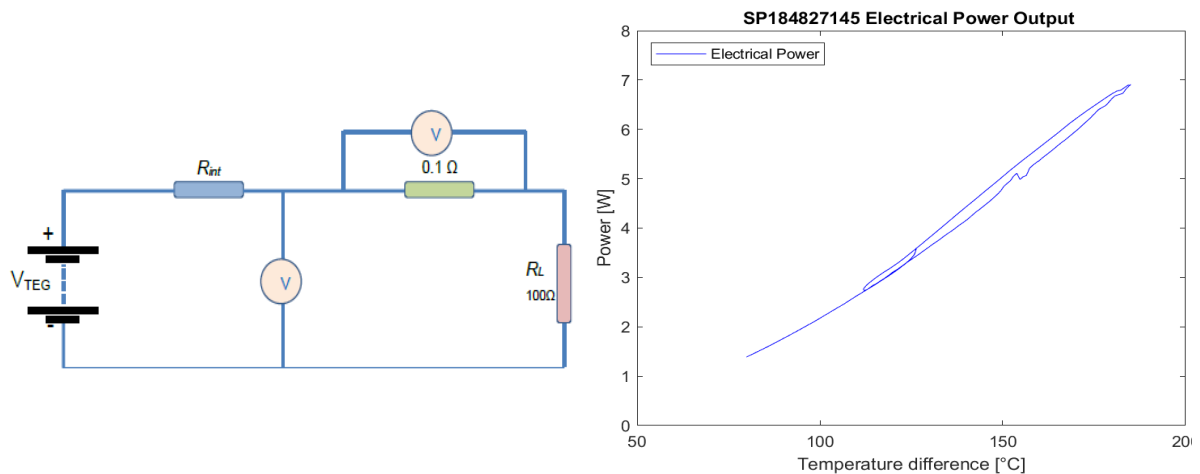

Fig. 4. SP184827145– electric circuit to measure voltage and current (left) and measured output power (right)

CONCLUSIONS

The maximum electrical energy that can be recovered from the waste heat of a water boiler system with combustion chamber has been investigated. For this purpose, a MATLAB Simulink model has been developed and was optimized using experimental data. The proposed system was a cascade installation of two Bismuth-Telluride TE modules (TEGW and TEGH).

In the ideal case, the maximum electric power output has been calculated to be 23.52W. It was established experimentally using an equivalent testing rig that the power output is strongly influenced by the quality of the thermic contact between surfaces. The calculation model has been optimized to include a correction factor for the thermal contact. When no special measures to improve the heat transmission were implemented, this factor has been determined to be 0.27. The calculated electrical power of the system in this case (3.52W) is the minimum that the cascade system could generate and represents 15% of the maximum calculated power. If the thermic contact is improved using thermal grease, the correction factor reduces to 0.1 and the calculated electrical power output is 9.32W, which represents 39.6% of the maximum one. It has been determined as well that in any of the considered conditions, the contribution of the TEGH to the total electrical power output is less than 10.8%, most of the electrical power being produced by TEGW. This is caused by the low temperature difference between feed water and output water and as well by the optimal working temperature difference of the chosen Bismuth-Telluride modules ($\Delta T \approx 150^{\circ}\text{C} \div 200^{\circ}\text{C}$).

Improvement of the thermal contact through control of the clamping force and consequently optimization of the calculation model should be considered by future studies. At the same time, a repositioning of TEGH in the system (for example in the gas exhaust system) might improve the total output.

Considering all the above, it can be concluded that while waste heat recovery using thermoelectric generators is appealing as method, the proposed cascade configuration does not bring too much in terms of electrical power gain compared to a single TE module and might be challenging to implement.

REFERENCES

- [1] International Energy Agency, “Global Energy & CO2 Status Report - The latest trends in energy and emissions in 2018,” IEA Publications, France, March 2019, pp.3-23
- [2] Buchberger K., Jungbauer J., Paukovits A., Pöschl H., Rauscher B., Ritter H., Vogl B., “Energierahmenstrategie 2030 für Wien,” Stadt Wien, Vienna, 2017, p.14
- [3] Bundesministerium für Nachhaltigkeit und Tourismus, “Energie in Österreich 2018 - Zahlen, Daten, Fakten,” Bundesministerium für Nachhaltigkeit und Tourismus, Vienna, 2018, p.22
- [4] Jan D. König et al “Thermoelektrik: Strom aus Abwärme,” FIZ Karlsruhe - Leibniz Institut für Informationsinfrastruktur GmbH, Bonn, 2016, p.3

- [5] Hussam Jouhara, Navid Khordehghah, Sulaiman Almahmoud, Bertrand Delpech,, “Waste heat recovery technologies and applications,” *Thermal Science and Engineering Progress*, pp. 268-289, 2018, p.270
- [6] Bhatia Anuj, “Improving Energy Efficiency of Boiler Systems,” *PDH Online*, Vancouver, 2012, p.10
- [7] Champier Daniel, “Thermoelectric generators: A review of applications,” *Energy Conversion and Management*, pp. 167-181, 23 February,2017, p. 168
- [8] Spirax Sarco, “Water-tube Boilers,” Spirax Sarco, 2019. [Online]. Available: <https://www.spiraxsarco.com/learn-about-steam/the-boiler-house/water-tube-boilers#article-top>. [Accessed 28 12 2019].
- [9] Spirax Sarco, “Shell Boilers,” Spirax Sarco, 2019. [Online]. Available: <https://www.spiraxsarco.com/learn-about-steam/the-boiler-house/shell-boilers>. [Accessed 27 12 2019]
- [10] GmbH, HERZ – Energietechnik, “pelletstar CONDENSATION - Betriebsanleitung,” Herz Energietechnik GmbH, Pinkafeld, 2019.
- [11] Huang-Liang Tsai, Jium-Ming Lin, “Model Building and Simulation of Thermoelectric Module Using Matlab/Simulink,” *Journal of Electronic Materials*, vol. 39, no. 9, pp. 2105-2111, 2010, p.2106
- [12] Davide Beretta et al, “Thermoelectrics: From history, a window to the future,” *Materials Science & Engineering R*, 24 July 2018.
- [13] Champier Daniel, “Thermoelectric generators: A review of applications,” *Energy Conversion and Management*, pp. 167-181, 23 February 2017.
- [14] Cheng Fuqiang, “Calculation Methods for Thermoelectric Generator Performance,” in *Thermoelectrics for Power Generation - A Look at Trends in the Technology*, Rijeka, InTech, 2016, pp. 481-506.
- [15] Yan David, “Modeling and Application of a Thermoelectric Generator,” University of Toronto, Toronto, 2011.
- [16] Huang-Liang Tsai, Jium-Ming Lin, “Model Building and Simulation of Thermoelectric Module Using Matlab/Simulink,” *Journal of Electronic Materials*, vol. 39, no. 9, pp. 2105-2111, 2010.
- [17] Filip Kuchta, Kamil Lubikowski, Jędrzej Maczak, “TEG Model in Matlab Simulink,” *Proceedings of the Institute of Vehicles*, vol. 4(113), pp. 63-74, 2017.
- [18] M. Elzalik, Hegazy Rezk, E.G. Shehata, Jean Thomas, R. Mostafa, “Thermoelectric Power Generation System - Simulation and Experimental Investigation,” in *Twentieth International Middle East Power System Conference (MEPCON)*, Cairo, Egypt, 2018.
- [19] Whei-Hsin Chen, Yi-Xian Lin, Xiao-Dong Wang, Yu-Li Lin, “A comprehensive analysis of performance of thermoelectric generators with constant and variable properties,” *Applied Energy*, vol. 241, pp. 11-24, 01 March 2019.
- [20] Merienne R., J. Lynn, E. McSweeney, S.M. O’Shaughnessy, “Thermal cycling of thermoelectric generators: The effect of heating rate,” *Applied Energy*, vol. 237, pp. 671-681, 2019.
- [21] Champier D., Bedecarrats J.P., Kousksou T., Rivaletto M., Strub F., Pignolet P., “Study of a TE (thermoelectric) generator incorporated in a multifunction wood stove,” *Energy*, vol. 36, pp. 1518-1526, 2011.
- [22] M. Tabakovic, “Analyze and optimize the prototype of a thermoelectric generator as an electric renewable poer source for biomass stoves,” *Fachhochschule Technikum Wien*, Pau, 2011.
- [23] Krzysztof Sornek, Mariusz Filipowicz, Maciej Zoladek, Radoslaw Kot, Malgorzata Mikrut, “Comparative analysis of selected thermoelectric generators operating with wood-fired stove,” *Energy*, vol. 133, pp. 1303-1313, 2019.
- [24] Rong Shen, Xiaolong Gou, Haoyu Xu, Kuanrong Qju, “Dynamic performance analysis of a cascaded thermoelectric generator,” *Applied Energy*, vol. 203, pp. 808-815, 2017.
- [25] TECTEG MFR., “Power module installation notes,” Thermal Electronics Corp., Ontario.

ALTERNATE FEEDSTOCKS IN THE REFINERY

James G. Speight¹, Ljiljana Radovanović²

¹CD & W Inc., 2476 Overland Road, Laramie, WY 82070-4808, USA

²University of Novi Sad, Technical Faculty "Mihajlo Pupin", Zrenjanin, Serbia

e-mail: JamesSp8@aol.com, ljiljap@tfzr.uns.ac.rs

Abstract: Over the past four decades, the energy industry has experienced significant changes in resource availability, petro-politics, and technological advancements dictated by the changing quality of refinery feedstock. However, the dependence to fossil fuels as primary energy source has remained unchanged. Advancements made in exploration, production, and refining technologies allow utilization of resources that might have been considered unsuitable in the middle decades of the 20th Century.

As the 21st Century opened, the refining industry entered a significant transition period and the continued reassessment by various governments, and the various levels of government, of oil importing policies and oil exporting policies. Therefore, it is not surprising that refinery operations have evolved to include a range of next-generation processes as the demand for transportation fuels and fuel oil has shown a steady growth. A major challenge is the feedstock composition because of the high content of heteroatoms (sulfur, nitrogen, oxygen) and heavy metals (particularly nickel and vanadium) and the high propensity for coke formation which is accompanied by a decrease in the yield of distillates.

In addition, the evolution of refinery processing to the use of alternate (non-fossil fuel) feedstocks is also presented in anticipation of domestic and industrial waste into the refinery for blending into conventional (fossil fuel) feedstocks or for separate processing. Many refineries may have already begun such planning by incorporating a gasifier on the refinery site. This will lead to the production of gaseous products, especially synthesis gas – a mixture of carbon monoxide and hydrogen – that can, through the Fischer-Tropsch process, give rise to a variety of products.

By understanding the evolutionary changes that have occurred to date, coupled with a presentation of possible future scenarios, this presentation will satisfy the needs of engineers and scientists at all levels from academia to the refinery and help in understanding the refining and prepare for the new changes and evolution of the industry.

Key words: Refinery configuration, biorefinery, gasification refinery, Fischer-Tropsch synthesis, alternate feedstocks, reconfigured refinery

INTRODUCTION

To meet the challenges from the changing trends in current feedstocks into a refinery to changes in the feedstock composition and also to changes in the product slate, the refinery will adapt to produce the ultimate amounts liquid fuels from the feedstock and maintain emissions within environmental compliance [1, 2, 3]. A major trend in the refining industry market demand for refined products will be in synthesizing fuels from simple basic reactants (such as synthesis gas) when it becomes uneconomical to produce super clean transportation fuels through conventional refining processes. Fischer-Tropsch plants together with IGCC systems will be integrated with or even into refineries, which will offer the advantage of high quality products [4].

This paper presents suggestions and opinions of the means by which refinery processes will evolve during the next three-to-five decades. Material relevant to (i) comparisons of current conventional feedstocks with viscous feedstocks and bio-feedstocks, (ii) the evolution of refineries since the 1950s, (iii) the properties and refinability of viscous feedstocks and bio-feedstocks, (iv) the choice between thermal processes and hydroprocesses, and (v) the evolution of products to match the environmental market.

REFINERY CONFIGURATION

Refineries need to be constantly adapted and upgraded to remain viable and responsive to ever changing patterns of crude supply and product market demands. As a result, refineries have been introducing increasingly complex and expensive processes to gain higher yields of lower boiling products from the higher boiling fractions and residua [5, 6].

Finally, the yields and quality of refined crude oil products produced by any given oil refinery depends on the mixture of crude oil used as feedstock and the configuration of the refinery facilities. Light/sweet crude oil is generally more expensive and has inherent great yields of higher value low boiling products such as naphtha, gasoline, jet fuel, kerosene, and diesel fuel. Viscous sour (high sulfur) feedstocks are generally less expensive and produces greater yields of lower value higher boiling products that must be converted into lower boiling products.

Crude Oil Refinery

A crude oil refinery is an industrial processing plant that is collection of integrated process units (Figure 1). The crude oil feedstock is typically a blend of two or more crude oils, often with viscous feedstocks blended in compatible amounts. With the depletion of known crude oil reserves, refining companies are having to seek crude oil in places other than the usual sources of supply.

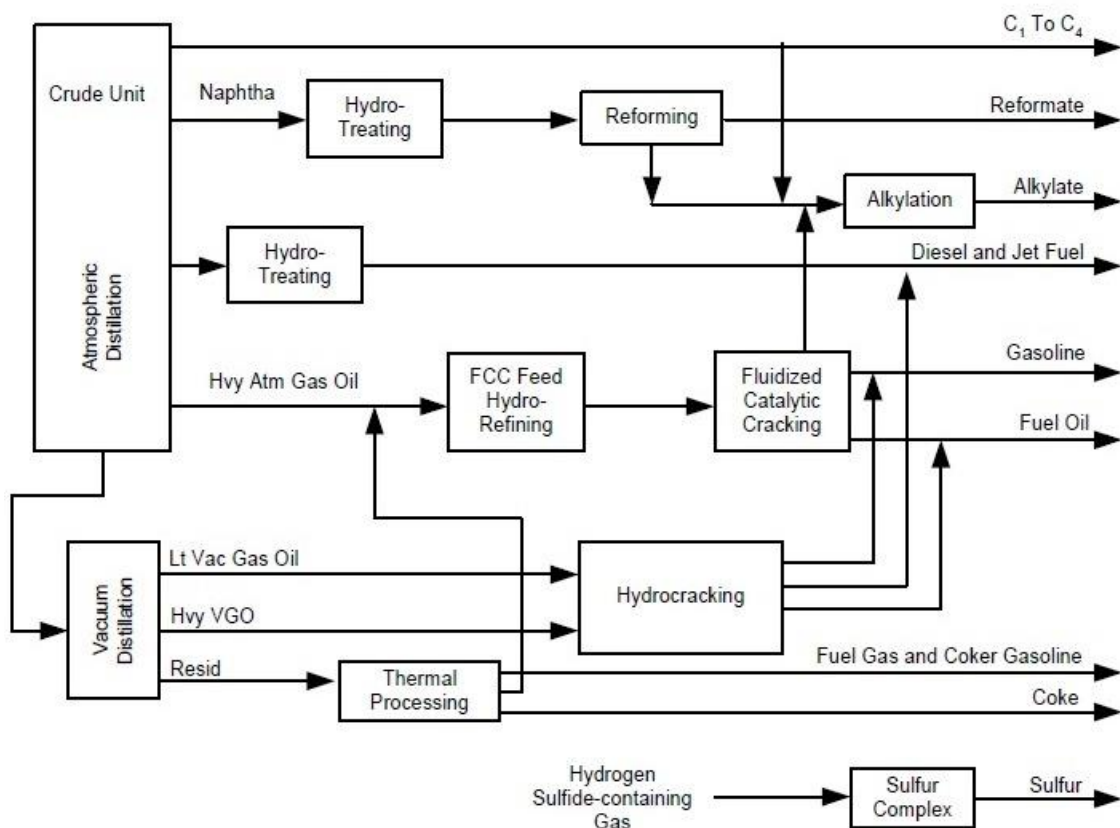

Fig. 1. General Layout of a Modern Refinery.

The definition of refinery feedstocks is often confusing and variable and has been made even confusing by the introduction of other terms that add little, if anything to crude oil definitions and terminology [3, 5, 6]. The configuration of refineries may vary from refinery to refinery. Some refineries may be more oriented toward the production of gasoline (large reforming and/or catalytic cracking) whereas the configuration of other refineries may be more oriented towards the production of middle distillates such as jet fuel, and gas oil.

Changes in the characteristics of conventional crude oil can be exogenously specified and will trigger changes in refinery configurations and corresponding investments. The future crude slate is expected to consist of larger fractions of both heavier, sourer crudes and extra-light inputs, such as natural gas liquids (NGLs). There will also be a shift towards bitumen, such as the Venezuelan extra heavy crude oil and the bitumen from the Canadian tar sands. These changes will require investment in upgrading, either at field level to process difficult-to-transport heavy crude oil, extra heavy crude oil, tar sand bitumen, either at a field site or at a remote refinery [3, 5, 6, 7].

Biorefinery

A biorefinery is a facility that integrates biomass conversion processes and equipment to produce fuels, power, and chemicals from biomass. The biorefinery concept is analogous to the crude oil refinery, which produce multiple fuels and products from crude oil [5, 6]. In fact, there is a renewed interest in the utilization of plant based matter (biomass) as a raw material feedstock for the chemicals industry [8, 9, 10, 11].

Plants offer a unique and diverse feedstock for chemicals. Plant biomass can be gasified to produce synthesis gas; a basic chemical feedstock and also a source of hydrogen for a future hydrogen economy [12]. In addition, the specific components of plants such as carbohydrates, vegetable oils, plant fiber and complex organic molecules known as primary and secondary metabolites can be utilized to produce a range of valuable monomers, chemical intermediates, pharmaceuticals and materials. More generally, biomass feedstocks are recognized by the specific plant content of the feedstock or the manner in which the feedstock is produced [3].

The simplest, cheapest and most common method of obtaining energy from biomass is direct combustion. In fact, the combustion process results in some form of organic residue after their primary use has been fulfilled. These organic residues can be used for energy production through direct combustion or biochemical conversion.

In a manner similar to the crude oil refinery, a biorefinery would integrate a variety of conversion processes to produce multiple product streams such as motor fuels and other chemicals from biomass. In short, a biorefinery would combine the essential technologies to transform biological raw materials into a range of industrially useful intermediates. However, the type of biorefinery would have to be differentiated by the character of the feedstock. For example, the *crop biorefinery* would use raw materials such as cereals or maize and the *lignocellulose biorefinery* would use raw material with high cellulose content, such as straw, wood, and paper waste.

However a word of caution about biomass. The aficionados of biomass use cite the fact that biomass is a carbon-zero feedstock insofar as the carbon dioxide emitted to the atmosphere from the use of biomass is offset by the uptake of carbon dioxide during the growth cycle of the biomass. But there are other, often unmentioned issues that must be addressed.

Biomass also contains varying quantities of metals, including alkali metals, alkaline earth metals, and heavy metals. The alkali metals consist of the chemical elements lithium (Li), sodium (Na), potassium (K), rubidium (Rb), cesium (Cs), and francium (Fr). Together with hydrogen they make up Group I of the Periodic Table. On the other hand, the alkaline earth metals are the six chemical elements in Group 2 of the Periodic Table and are beryllium (Be), magnesium (Mg), calcium (Ca), strontium (Sr), barium (Ba), and radium (Ra). Finally, the heavy metals are less easy to define but are generally recognized as metals with relatively high density, atomic weight, or atomic number. The common transition metals such as copper (Cu), lead (Pb), and zinc (Zn) are often classed as heavy metals but the criteria used for the definition and whether metalloids (types of chemical elements which have properties in between, or that are a mixture of, those of metals and nonmetals) are included, vary depending on the context. These metals are often found in functional molecules such as the porphyrin molecules which include chlorophyll and which contains magnesium. The presence of these metals requires additional treatment to ensure that release into the environment is mitigated.

By analogy with crude oil, every element of the plant feedstock will be utilized including the low value lignin components. However, the different compositional nature of the biomass feedstock, compared to crude oil, will require the application of a wider variety of processing tools in the biorefinery. Processing of the individual components will utilize conventional

thermochemical operations and state-of-the-art bioprocessing techniques. The production of biofuels in the biorefinery complex will service existing high volume markets, providing economy-of-scale benefits and large volumes of by-product streams at minimal cost for upgrading to valuable chemicals.

Gasification Refinery

The most likely option for the integration of alternate feedstock into the refinery is the installation of an on-site gasifier. Thus, such a refinery (often referred to as a gasification refinery) would have, as the center piece, gasification technology as is the case of the Sasol refinery in South Africa [13]. The refinery would produce synthesis gas (from the carbonaceous feedstock) from which liquid fuels would be manufactured using the Fischer-Tropsch synthesis technology [3, 5]. Synthesis gas is used as a source of hydrogen or as an intermediate in producing hydrocarbon derivatives via the Fischer-Tropsch synthesis [12, 14]. In fact, gasification to produce synthesis gas can proceed from any carbonaceous material, including biomass. Inorganic components of the feedstock, such as metals and minerals, are trapped in an inert and environmentally safe form as char, which may have use as a fertilizer. Biomass gasification is therefore one of the most technically and economically convincing energy possibilities for a potentially carbon neutral economy.

Moreover, the gasification of carbonaceous feedstock can provide high purity hydrogen for a variety of uses within the refinery [5, 6]. Hydrogen is used in the refinery to remove sulfur, nitrogen, and other impurities from intermediate to finished product streams and in hydrocracking operations for the conversion of high boiling distillates into low boiling products, such as naphtha, kerosene, and atmospheric gas oil. Hydrocracking and severe hydrotreating require hydrogen which is at least 99% v/v pure, while less severe hydrotreating can use 90% v/v pure hydrogen and above and a current refinery typically requires continuous hydrogen availability [5, 6].

Fischer-Tropsch Synthesis

The synthesis reaction is dependent of a catalyst, mostly an iron or cobalt catalyst where the reaction takes place. There is either a low or high temperature process (LTFT, HTFT), with temperatures ranging between 200 to 240°C for LTFT and 300 to 350°C for HTFT. The high temperature Fischer Tropsch technology uses a fluidized catalyst at 300 to 330°C (625°F). Originally circulating fluidized bed units were used (Synthol reactors). Since 1989 a commercial scale classical fluidized bed unit has been implemented and improved upon.

The reactors are the multi-tubular fixed bed, the slurry or the fluidized bed (with either fixed or circulating bed) reactor. The fixed bed reactor consists of thousands of small tubes with the catalyst as surface-active agent in the tubes. Water surrounds the tubes and regulates the temperature by settling the pressure of evaporation. The slurry reactor is widely used and consists of fluid and solid elements, where the catalyst has no particular position, but flows around as small pieces of catalyst together with the reaction components. The slurry and fixed bed reactor are used in LTFT. The fluidized bed reactors are diverse, but characterized by the fluid behavior of the catalyst. The low temperature Fischer Tropsch technology has originally been used in tubular fixed bed reactors at 200 to 230 °C. This produces a more paraffinic and waxy product spectrum than the high temperature technology.

A new type of reactor (the Sasol slurry phase distillate reactor has been developed and is in commercial operation. This reactor uses a slurry phase system rather than a tubular fixed bed configuration and is currently the favored technology for the commercial production of synfuels.

PRODUCTS FROM ALTERNATE FEEDSTOCKS

Alternate feedstocks such as the biomass-based feedstocks, can be converted into liquid or gaseous forms for the production of electric power, heat, chemicals, or gaseous and liquid fuels though the varying contents of cellulose, hemicellulose, and lignin (Table 2). The predominant conversion processes are direct liquefaction, indirect liquefaction, physical extraction, thermochemical conversion, biochemical conversion, and electrochemical conversion. More generally, the production of biofuels from lignocellulosic feedstocks can be achieved through two different processing routes: (i) the thermochemical platform and (ii) the bioconversion platform (Chapter 14). While each platform is adequate to the task, depending upon the feedstock, there is no clear candidate for best pathway between the various thermochemical technologies and the biochemical technologies.

Table 2. Amounts (% w/w) of Cellulose, Hemicellulose and Lignin Common Agricultural Residues and Wastes*

<i>Agricultural residue</i>	<i>Cellulose</i>	<i>Hemicellulose</i>	<i>Lignin</i>
Bamboo	41-49	24-28	24-26
Coastal Bermuda grass	25	35.7	6.4
Corn cobs	45	35	15
Corn stover	35	28	16-21
Cotton seed hairs	80-90	5-20	0
Grasses	25-40	35-50	10-30
Hardwood stem	40-50	24-40	18-25
Leaves	15-20	80-85	0
Newspaper	40-55	25-40	18-30
Nut shells	25-30	25-30	30-40
Paper	85-99	0	0-15
Primary wastewater solids	8-15	NA	24-29
Rice straw	40	18	5.5
Softwood stem	45-50	25-35	25-35
Solid cattle manure	1.6-4.7	1.4-3.3	2.7-5.7
Sorted refuse	50-60	10-20	15-20
Sugar cane bagasse	32-48	19-24	23-32
Sweet sorghum	27	25	11
Swine waste	6.0	28	-
Switch grass	30-51	10-50	5-20
Waste papers from chemical pulps	60-70	10-20	5-10
Wheat straw	33-40	20-25	15-20

*Listed alphabetically rather than by any preferences.

Type	Cellulose	Hemicellulose	Lignin	Others*	Ash
Soft wood	41	24	28	2	0.4
Hard wood	39	35	20	3	0.3
Pine bark	34	16	34	14	2
Straw (wheat)	40	28	17	11	7
Rice husks	30	25	12	18	16
Peat	10	32	44	11	6

*Metals content is not differentiated in this analysis.

Table 2. Summary of the Methods for the Conversion of Biomass to Fuels.

Biomass			
	Extraction		
		Transesterification	Biodiesel
	Hydrolysis		
		Fermentation	Biogas
			Ethanol
	Gasification		
		Synthesis gas	Biogas
			Hydrogen
			Methanol
			Ethanol
	Pyrolysis		Hydrogen
			Bio-oil
	Hydrotreating		Diesel

The thermochemical platform typically uses a combination of pyrolysis, gasification, and catalysis to transform the feedstock into gaseous products – one of which is synthesis gas and then into fuels or chemicals. Synthesis gas (also referred to as syngas) production through pyrolysis is accompanied by the generation of char, which can then be gasified to provide process heat and energy for the thermochemical platform.

On the other hand, the bioconversion platform typically uses a combination of physical or chemical pretreatment and enzymatic hydrolysis to convert lignocellulose into its component monomers. This platform (examples are anaerobic digestion and fermentation) uses biological agents to carry out a structured deconstruction of lignocellulose components and combines process elements of pretreatment with enzymatic hydrolysis to release carbohydrates and lignin from the wood. The advantage of the bioconversion platform is that it provides a range of intermediate products, including glucose, galactose, mannose, xylose, and arabinose, which can be relatively easily processed into value-added bioproducts. The bioconversion platform also generates a quantity of lignin or lignin components; depending upon the pretreatment, lignin components may be found in the hydrolysate after enzymatic hydrolysis, or in the wash from the pretreatment stage.

Once hydrolyzed, six-carbon sugars can be fermented to ethanol using age-old yeasts and processes. Five-carbon sugars, however, are more difficult to ferment; new yeast strains are being developed that can process these sugars, but issues remain with process efficiency and the length of fermentation. Other types of fermentation, including bacterial fermentation under aerobic and anaerobic conditions, can produce a variety of other products from the sugar stream, including lactic acid. Bioconversion proceeds at lower temperatures and lower reaction rates and can offer high selectivity for products. Ethanol production is a biochemical conversion technology used to produce energy from alternate fuel feedstocks, depending upon the type and properties of the feedstock. For ethanol production, biochemical conversion researchers have focused on a process model of dilute acid hydrolysis of hemicelluloses followed by enzymatic hydrolysis of cellulose. Biodiesel production is a biochemical conversion technology used to produce energy from oilseed crops.

Cellulosic materials can be used to produce ethanol which represents an important, renewable liquid fuel for motor vehicles. Production of ethanol from alternate fuel feedstocks is one way to reduce both the consumption of crude oil and environmental pollution. In order to produce ethanol from cellulosic materials, a pretreatment process is used to reduce the sample size, break down the hemicelluloses to sugars, and open up the structure of the cellulose component. The cellulose portion is hydrolyzed by acids or enzymes into glucose sugar that is fermented to ethanol. The sugar derivatives from the hemicellulose feedstocks are also fermented to ethanol.

The fermentation process requires pretreatment of the feedstock by chemical, physical, or biological means to reduce the complex carbohydrates to simple sugars. This type of pretreatment is often referred to as hydrolysis. The resulting sugars can then be fermented by the yeast and bacteria employed in the process. Furthermore, feedstocks that have a high content of starch and sugar are most easily hydrolyzed. Cellulosic feedstocks, including the major fraction of organics in MSW, are more difficult to hydrolyze, requiring more extensive pretreatment. Fermentation is generally used industrially to convert substrates such as glucose to ethanol for use in beverage, fuel, and chemical applications and to other chemicals (e.g., lactic acid used in producing renewable plastics) and products (e.g., enzymes for detergents). Strictly speaking, fermentation is an enzymatically controlled anaerobic process although the term is sometimes more loosely applied to include aerobic processing as well.

The bioconversion platform is an industrial option that might be used in a biorefinery (Chapter 12) for producing fuels from alternate fuel feedstocks using biochemical reactions and/or biochemical agents. For example, fermentation or anaerobic digestion to produce fuels and chemicals from organic sources is a bioconversion platform. The bioconversion platform therefore has the ability to serve as the basis for wood-based biorefining operations, generating value-added bioproducts as well as fuel and energy for the forest sector.

THE RECONFIGURED REFINERY

Over the past three decades, the refining industry has been challenged by changing feedstocks and product slate. In the near future, the refining industry will become increasingly flexible with improved technologies and improved catalysts. The main technological progress will be directed to (i) upgrading viscous feedstocks, (ii) production of cleaner – less environmentally threatening – transportation fuel production and (iii) the integration of refining and petrochemical businesses.

Even the tried and true processes [5, 6] will see changes as they evolve [15].

In the integration of refining and petrochemical businesses, new technologies based on the traditional fluid catalytic cracking process will be of increased interests to refiners because of their potential to meet the increasing demand for light olefins. Meanwhile, hydrocracking, due to its flexibility, will take the central position in the integration of refining and petrochemical businesses in 21st century

The typical refinery in the year 2050 will be located at an existing refinery site since economic and environmental considerations may make it difficult and uneconomical to build a new refinery at another site. Many existing refining process may still be in use but they will be more efficient and more technologically advanced and perhaps even rebuilt (reactors having been replaced on a scheduled or as needed basis) rather than retrofitted. However, energy efficiency will still be a primary concern, as refiners seek to combat the inevitable increasing cost of crude oil and refinery operating expenses.

The refinery of the future will have a gasification section devoted to the conversion of carbonaceous feedstocks, such as biomass, to Fischer-Tropsch hydrocarbon derivatives. The biomass refinery of the future will also use multiple feedstocks but also it will be able to shift output from the production of one chemical to another in response to market demands. Given that biomass will be a part of a refinery of the future, refiners may dictate that biomass receives preliminary upgrading at the biomass site before being shipped to the crude oil refinery.

To circumvent these issues, there may be no way out of energy production than to consorting alternative energy sources with crude oil, and not of opposing them. This leads to the concept of alternative energy systems, which is wider-ranging and more meaningful than alternative energy sources, because it relate to the actual transformation process of the global energy system [16]. Alternative energy systems integrate crude oil with other energy sources and pave the way for new systems where refinery flexibility will be a key target, especially when related to the increased use of renewable energy sources.

Low quality vegetable oils and greases are likely to be promising in a short-to-medium term to yield diesel fuel and jet-fuel by means of hydroprocessing triglyceride-based feedstocks. Also, processing pyrolysis oil requires larger efforts in commercial development because of the overall poor quality of the bio-oils, the conventional hydrotreating catalysts are expected to have a considerably lower catalyst life in bio-oil upgrading operations than that observed with a crude oil-based feedstock.

While the current generation commercial catalysts are excellent hydroprocessing catalysts, they are optimized for crude oil-based feedstock and, since the bio-oils have significantly different properties than petroleum feedstock, it would be worthwhile to dedicate efforts to developing catalysts specifically designed for upgrading bio-oils.

Most of the biomass conversion processes carried out in a refinery need a high amount of hydrogen in order to remove oxygen and yield high energy density fuels. Although biomass valorization can be performed on current commercially available petroleum-based technology, it should not be forgotten that crude oil and biomass feedstocks are chemically different. Nevertheless, heterogeneous catalysis, which has made it possible to convert efficiently crude oil-derived resources to fuels, will also be able to provide the necessary technology to get similar fuels starting from biomass feedstocks providing a new catalyst technology is developed [17].

REFERENCES

- [1] Penning, R.T. Petroleum Refining: A Look at The Future. *Hydrocarbon Processing*, 80(2): 45-46, 2001.
- [2] Davis, R.A., and Patel, N.M. 2004. Refinery Hydrogen Management. *Petroleum Technology Quarterly*, Spring: 29-35.
- [3] Speight, J.G. *Handbook of Synthetic Fuels: Properties, Processes, and Performance* 2nd Edition. McGraw-Hill, New York, 2020.
- [4] Stanislaus, A., Qabazard, H., and Absi-Halabi, M.: Refinery of the Future. Proceedings. 16th World Petroleum Congress, Calgary, Canada. June 11 – 15, 2000.
- [5] Speight, J.G. *The Chemistry and Technology of Petroleum* 5th Edition. CRC Press, Taylor & Francis Group, Boca Raton, Florida, 2014.
- [6] Speight, J.G. 2017. *Handbook of Petroleum Refining*. CRC Press, Taylor & Francis Group, Boca Raton, Florida.
- [7] Speight, J.G. *Shale Oil and Gas Production Processes*. Gulf Publishing Company, Elsevier, Cambridge, Massachusetts, 2020.
- [8] Marcilly, C. Present status and future trends in catalysis for refining and petrochemicals. *Journal of Catalysis*, 216(1-2), 47-62, 2003.
- [9] Huber, G.W., Corma, A. Synergies between Bio- and Oil Refineries for the Production of Fuels from Biomass. *Angewandte Chemie*, 46(38):7184-7201, 2007.
- [10] Lynd, L.R., Wyman, C., Laser, M., Johnson, D., and Landucci, R. Strategic Biorefinery Analysis: Review of Existing Biorefinery Examples January 24 -July 1, 2002. Subcontract Report NREL/SR-510-34895 October. National Renewable Energy Laboratory, Golden, Colorado, 2005.
- [11] Lynd, L.R., Larson, E., Greene, N., Laser, M., Sheehan, J., Dale, B.E., McLaughlin, S., and Wang, M. Biofuels, Bioproducts, and Biorefining. 3(2) 113-123, 2009.
- [12] Speight, J.G. *Synthesis Gas: Production and Properties*. Scrivener Publishing, Beverly, Massachusetts, 2020.
- [13] Couvaras, G. Sasol's Slurry Phase Distillate Process and Future Applications. Proceedings. Monetizing Stranded Gas Reserves Conference, Houston, December 1997.
- [14] Speight, J.G. *Handbook of Petrochemical Processes*. CRC Press, Taylor & Francis Group, Boca Raton, Florida, 2019.
- [15] Speight, J.G. *The Refinery of the Future*. Gulf Professional Publishing Company, Elsevier, Oxford, United Kingdom, 2011.
- [16] Szklo, A., and Schaeffer, R. Alternative Energy Sources or Integrated Alternative Energy Systems? Oil as a Modern Lance of Peleus for The Energy Transition. *Energy*, 31: 2513-2522., 2005.
- [17] Melero, J.A., Iglesias, J., and Garcia, A. Biomass as Renewable Feedstock in Standard Refinery Units. Feasibility, Opportunities and Challenges. *Energy Environ. Sci.*, 5: 7393-7420., 2012.

MATHEMATICAL MODELS APPLIED FOR EXPERIMENTS ON BIOGAS PRODUCTION AT SMALL SCALE

Adrian Eugen Cioablă¹, Gabriela-Alina Dumitreț², Ana Maria Pană², Valentin Ordod²,
Dorin Lelea¹, Mădălina Ivanovici², Francisc Popescu^{1*}, Luisa Izabel Dungan¹

¹Politehnica University Timișoara, Mechanical Engineering Faculty,
Mihai Viteazu Blv 1, 300222, Timișoara, România,

² University Politehnica of Timisoara, Faculty of Industrial Chemistry and Environmental
Engineering, Vasile Parvan Blv., no. 6, 300223, Timisoara, Romania

e-mail: adrian.cioabla@upt.ro, francisc.popescu@upt.ro

Abstract: Nowadays there is a great concern relative to using biofuels according to the increasing energy demand correlated with the depletion of fossil fuels all over the world. In this context, solutions are researched and found in order to use all the existing renewable resources. Biogas, as one form of biomass conversion, represents an energy carrier which is used in all developed or developing countries. In this context, Romania as a developing country needs to step up its activities in terms of finding solutions to better use all the residual materials with impact on biogas production as a solution.

The current paper will present the efficiency of anaerobic digestion of two material substrates in a small-scale reactor (total volume of 5 L). In order to understand the mechanisms, which underlie the batch fermentation process, and to evaluate it, modified Gompertz model and the logistical growth model were used.

Key words: Biogas; vegetal substrates; small scale installations.

INTRODUCTION

Anaerobic digestion is a good alternative to the energy needs that the modern world faces. This process is a biochemical one, consisting in the production of biogas as a result of organic compound degradation in the absence of oxygen [1,2]. The biogas produced is rich in methane and carbon dioxide. Depending on the source, the methane content may be between 45 to 70% and the content of carbon dioxide between 30 to 45%. In the biogas it can be also found water, nitrogen, hydrogen, hydrogen sulphide, oxygen, halogenated compounds and ammonia [3-5].

Biogas can be used to generate heat in combustion systems (boilers, turbines), electricity in fuel cells, can be converted into heat and electricity in combined heat and power (CHP) plants or can be converted into hydrogen by biogas reforming [6,7].

Due to their high content of carbohydrates and nitrogen, agricultural wastes represent an important source of biomass. According to the 2017 statistical report of European Biogas Association, the number of biogas plants in Europe increased almost three times compared to 2009, reaching 17662 plants in 2016. 67% of that growth was due to biogas plants running on agricultural substrates [8].

In Romania, the agriculture plays an important role in the economic development of the country. Data from the European Institute of Statistics - Eurostat - showed that in 2018, Romania ranks first in European maize and sunflower production, fourth in the European wheat production and fifth in rapeseed production. As a result of these activities, huge amounts of agricultural residues are produced. These can be used to produce renewable energy. According to N. Scarlat et al. [9] the amount of agricultural crop residues available for bioenergy in Romania was estimated at 137.1 PJ.

The mathematical modelling of anaerobic digestion can give important information on the process efficiency in different condition, allowing to identify the effect of different parameters on the digestion efficiency. In the literature there are a lot of models used to describe the kinetics of methane production during the digestion process of diverse substrates [10-14].

In this context, the objective of the present study was to investigate the anaerobic digestion efficiency of two degraded cereals. In order to describe the kinetics of the process, the modified Gompertz model and the logistical growth model were applied and evaluate.

Substrates

The anaerobic digestion performances of the following degraded agricultural biomasses were investigated in this study: wheat bran and rye. In the preparation of the substrates was used water from the centralized water supply system.

Experimental set-up

The laboratory scale experimental setup simulates an anaerobic digestion process and allow to evaluate and compare the performances of different substrates. Two batch reactors with a volume of 6L each, were used in this study.

The schematic diagram of the experimental set-up is presented in Fig. 1.

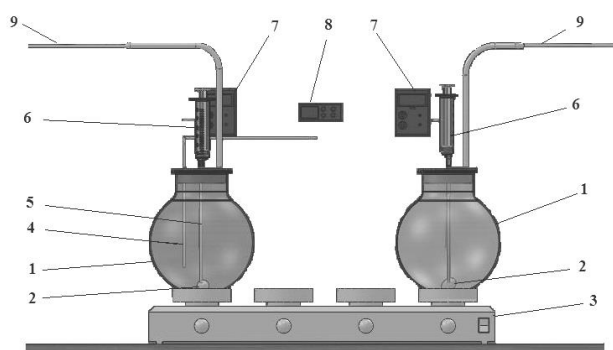

Fig. 1. Schematic diagram of experimental setup

The experimental setup is composed from: 1 – thermal glass reactors with a total volume of 6L, covered with a layer of black paint; 2 – magnets used for magnetic stirring of the material suspensions; 3 – device used for heating the suspension inside the glass reactors; 4 – thermocouple; 5 – system for sampling and pH correction of the suspensions inside the vessels; 6 – syringe used for sampling and pH correction system; 7 - pH controllers connected to pH sensors inside the glass reactors in order to determine in real time the pH value of the suspension; 8 – temperature controller connected with the thermocouple; 9 – gas bags with a total volume of 2L used to collect the biogas produced in the fermentation process.

The fermentation process was carried out at temperatures between 30 and 35 °C, for 35 days in order to observe the pH, the biogas yield and its composition in terms of CH₄ and CO₂ concentration. For the pH correction during the process, a 10% NH₃ solution was used.

The methane and carbon dioxide concentration in the biogas was measured with a DELTA 1600 S IV gas analyzer.

Chemical analysis

The physical and chemical characteristics of substrates and digestates produced at the end of the anaerobic process were evaluated according to the following standards:

EN 14774 – Solid biofuels – Determination of moisture content – Oven dry method (parts 2 and 3) [15];

EN 14775 - Solid biofuels - Determination of ash content [16];

EN 14918 - Solid biofuels – Determination of calorific value [17];

EN 15290 – Solid biofuels – Determination of major elements [18];

EN 15297 – Solid biofuels – Determination of minor elements [19];

EN 15104 – Solid biofuels – Determination of total content of carbon, hydrogen and nitrogen – Instrumental methods [20];

EN 15148 – Solid biofuels – Determination of the content of volatile matter [21].

All analyses were performed in duplicate.

Mathematical Models

In order to calculate and compare the methane production during anaerobic digestion of substrates investigated, the following mathematical models were used [22]:

Logistical growth model

$$M = M_p / (1 + b * \exp(-k * t)) \quad (1)$$

where: M is the cumulative equivalent methane yield at time t, in m³, M_p is the methane production potential in m³, b is a dimensionless constant, k is kinetic hydrolysis reaction rate constant, day⁻¹, t is the time, expressed in days of the process, and exp(1) is 2.7183.

The modified Gompertz model [23]:

$$M = M_p * \exp(- \exp(R_m * \exp(1) / M_p * (\lambda - t) + 1)) \quad (2)$$

where: M is the cumulative equivalent methane yield at time t, m³, M_p is the methane production potential, m³, R_m is the maximum methane production rate, m³/days, λ is the period of lag phase, days, t is the time expressed in days of the process, and exp(1) = 2.7183.

The parameters of the model were calculated by non-linear unconstrained optimization method, using the Nelder-Mead algorithm, which minimizes a scalar-valued nonlinear function of n real variables, by using only function values [24].

In order to determine the mentioned parameters the Matlab R2018a Software was used. The quality and appropriation of the model were first evaluated graphically and further, the mean square error (MSE), root mean square error (RMSE), relative absolute error (rAE), correlation coefficient (R), and coefficient of determination (R²) were calculated.

MATERIAL AND METHODS

The main characteristics of wheat bran and rye used in the anaerobic digestion are listed in Table 1.

Table 1. Main parameters of biomasses used in the anaerobic digestion process

	Wheat bran	Rye
Moisture content (db) (%)	9.72	10.00
Ash content (db) (%)	5.54	1.67
Gross calorific value (db)(J/g)	19034	18632
Net calorific value (db)(J/g)	17520	17302
Carbon content (%)	41.3	40.4
Hydrogen content (%)	6.2	6.3
Nitrogen content (%)	2.06	1.44
Volatile matter content (db) (%)	78.4	84.4
C/N ratio	20.05	28.06

It can be observed from the table above that the calorific value for both materials presents high value which can be interpreted as high energetic capacity which can be capitalized. Also the C/N ratio is well inside the domain 20-30 which is characteristic for good quality fermentation processes.

The digestion process was conducted in a batch reactor, for a period of 35 days. The evolution of pH and temperature during this fermentation period is presented in fig. 2 and 3 respectively.

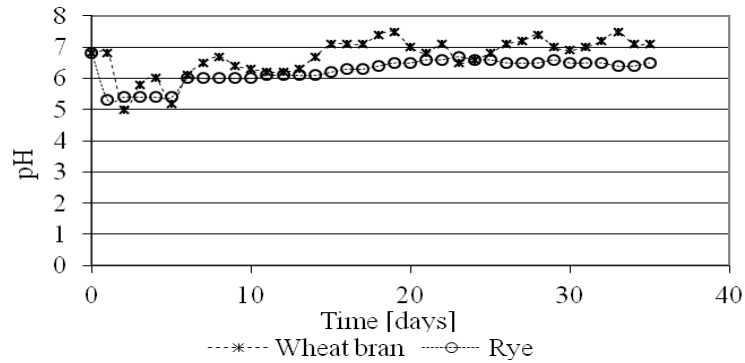

Fig. 2. pH evolution during the anaerobic digestion process

From Fig. 2 it can be determined that the pH is relatively low in the period of 8 days and after, by using a correction agent based on a lime suspension, the pH was risen to the specific values for a correct fermentation, which is between 6.5 – 7.5.

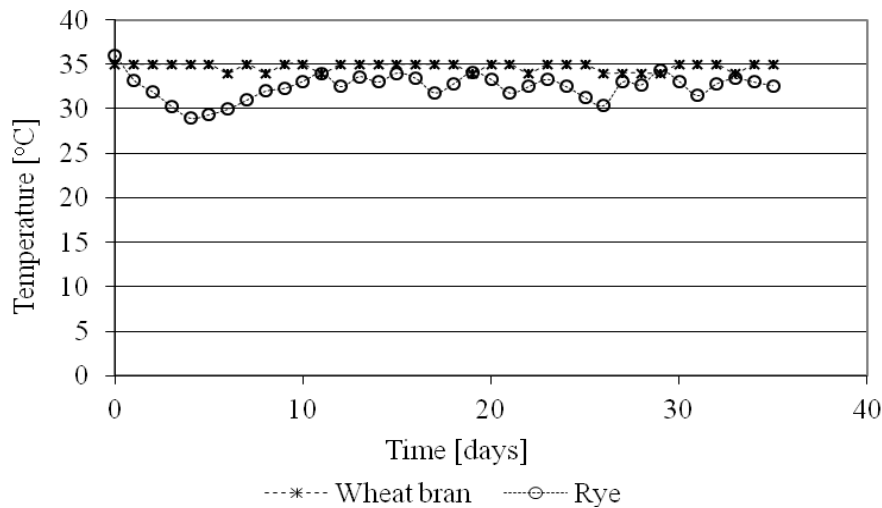

Fig. 3. Temperature evolution during the anaerobic digestion process

Temperature was, as pH, monitored on a daily basis and presents values averaging between 30 °C and 35 °C. The mentioned values are correspondent to mesophilic temperature regime, which was tested for both batches of material.

RESULTS AND DISCUSSIONS

The cumulative biogas production for the two substrates was calculated and is presented in Fig. 4.

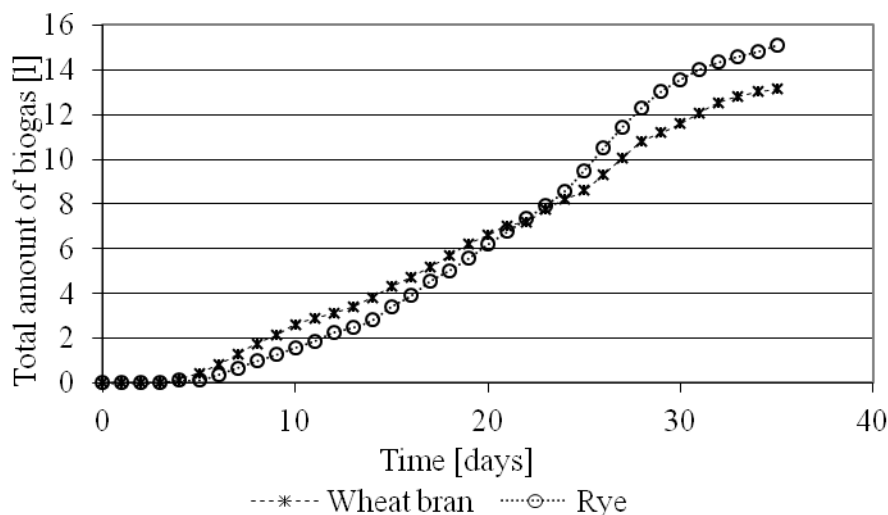

Fig. 4. Cumulative biogas production

From Fig. 4, it can be noticed that biogas production follows the same trends for both substrates investigated, but the total amount produced is superior in the case of rye (15 m³). The best explanation for this aspect is that the bacteria had a better environment, even if the initial conditions were the same, and developed faster, thus obtaining higher biogas quantities. The characteristics of the two digestates used are presented in Table 2.

Table 2. Main properties of digestate formed during anaerobic digestion process

	Digestate from wheat bran	Digestate from rye
Moisture content (db) (%)	2.58	4.98
Ash content (db) (%)	53.1	16
Gross calorific value (db)(J/g)	10765	18103
Net calorific value (db)(J/g)	9323	16564
Carbon content (%)	57.1	47.9
Hydrogen content (%)	6.4	5.8
Nitrogen content (%)	11.0	4.14
Volatile matter content (db) (%)	62.1	70.4
C/N ratio	5.19	11.57

It can be observed that the calorific value decreased with almost 50% for wheat bran and with about 10% for rye. This could be explained by the fact that rye is a better material for this type of processes in relation with the produced quantity. Also the digestate ash content is very high, mainly because of the lime based suspension used for pH corrections. This aspect makes the digestates unusable for combustion processes because of the high quantity of residual material, but it can be still used as fertilizer in agriculture.

In order to determine the maximum CH₄ production potential (M_p), CH₄ production rate (R_m) and lag phase (λ) the modified Gompertz equation was used. Fig. 5 shows the fit of the Gompertz model to the experimental data.

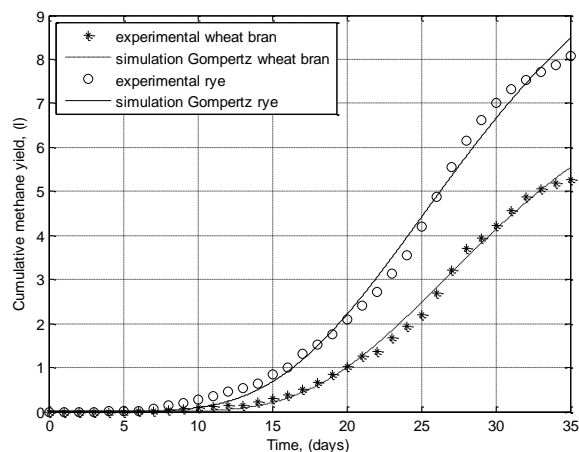

Fig. 5. Comparison of experimental data and simulation data using modified Gompertz model

The kinetic parameters of the model were determined by non-linear unconstrained optimization method. The results are shown in table 3 together with the statistical parameters used to measure the accuracy of the model.

Table 3. Parameters of modified Gompertz mathematical model and the values of model performances

Substrate used	Model parameters			MSE ^a	RMSE ^b	rAE ^c	R ^d	R ² ^e
	M _P (l)	R _m (l/days)	λ (days)					
Wheat bran	8.1568	0.3380	17.7247	0.0122	0.1105	9.9743e-04	0.9983	0.9979
Rye	11.9491	0.4664	15.5539	0.0430	0.2072	0.0012	0.9975	0.9972

^a mean square error; ^b root mean square error; ^c relative absolute error; ^d correlation coefficient; ^e coefficient of determination

Table 3 revealed that the methane production rate is higher in the case of rye, which is confirmed by the higher quantity of methane produced in this case. The values of λ kinetic parameter indicate that the bacteria from rye need less time to adapt in the liquid substrate from digester.

The second model used to determine the methane production potential of the investigated substrates was the logistical growth model. The experimental data and the models values are presented in fig. 6.

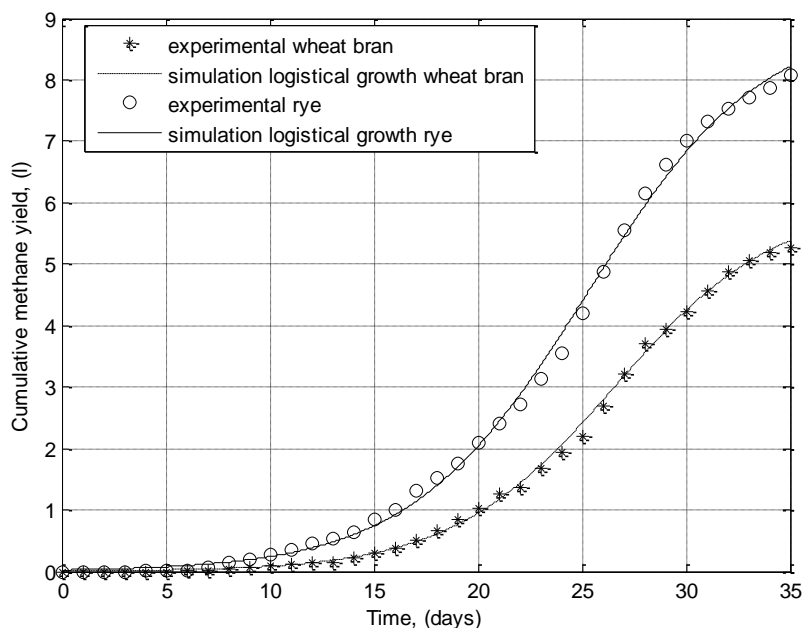

Fig. 6. Comparison of experimental data and simulation data using logistical growth model

The values of model parameters and the statistical parameters used to measure the accuracy of the model are presented in table 4.

Table 4. Parameters of logistical growth mathematical model and the values of model performances

Substrate used	Model parameters			MSE ^a	RMSE _b	rAE ^c	R ^d	R ^{2 e}
	M _p (l)	b	k (1/days)					
Wheat bran	6.0035	899.9417	0.2559	0.0041	0.0639	4.9229e-04	0.9994	0.9993
Rye	9.0210	392.7410	0.2368	0.0144	0.1198	6.4837e-04	0.9991	0.9991

^a mean square error; ^b root mean square error; ^c relative absolute error; ^d correlation coefficient; ^e coefficient of determination

As it can be seen from Fig. 6 and Table 4, the logistical growth model estimate very well the methane production potential.

Both models provide good values of statistical parameters, but the logistical growth model displayed better values, meaning that this model make a more accurate estimation of phenomena produced during the anaerobic digestion of investigated substrates.

CONCLUSIONS

Anaerobic digestion of the two substrates studied showed that rye is more suitable for this process, both in terms of biogas production and its composition in methane.

In addition, two kinetic models were used to simulate the methane production during the process and estimate the maximum methane production. Both models are very useful to understand the effect of various parameters on the process efficiency. In this care, the logistic model described and estimated more accurately the methane production.

REFERENCES

- [1] Le Zhang, Kai-Chee Loh, Jingxin Zhang, Enhanced biogas production from anaerobic digestion of solid organic wastes: current status and prospects, *Bioresource Technology Reports*, Volume 5, February 2019, Pages 280-296.
- [2] Bharathiraja, Dr.B. & Sudharsana, T & Jayamuthunagai, J & Ramanujam, Praveen Kumar & Sivasankaran, Chozhavendhan & Iyyappan, Jayaraj. (2018). Biogas production – A review on composition, fuel properties, feed stock and principles of anaerobic digestion. *Renewable and Sustainable Energy Reviews*, 90, 2018, 570 – 582
- [3] Rasi, Saija Emilia, Biogas composition and upgrading to biomethane, University of Jyvaskyla, Finland, Publishing unit University Library of Jyvaskyla, 2009, 76p.
- [4] Yue Li, Yinguang Chen, Jiang Wu, Enhancement of methane production in anaerobic digestion process: A review, *Applied Energy*, Volume 240, 15 April 2019, Pages 120-137.
- [5] Robert Bedoić, Lidija Čuček, Boris Čosić, Damjan Krajnc, Goran Smoljanić, Zdravko Kravanja, Davor Ljubas, Tomislav Pukšec, Neven Duić, Green biomass to biogas – A study on anaerobic digestion of residue grass, *Journal of Cleaner Production*, Volume 213, 10 March 2019, Pages 700-709.
- [6] Ramírez, Martín & Gómez, J & D, Cantero,. Biogas: sources, purification and uses, In book: *Hydrogen and Others technologies 11*, Chapter: 13, Publisher: Studium Press LLC, Editors: U.C. Sharma, S. Kumar, R. Prasad, pp.296-323, 2015.
- [7] Willian César Nadaleti, Utilization of residues from rice parboiling industries in southern Brazil for biogas and hydrogen-syngas generation: Heat, electricity and energy planning, *Renewable Energy*, Volume 131, February 2019, Pages 55-72.
- [8] European Biogas Association Statistical Report 2017, <http://european-biogas.eu/wp-content/uploads/2017/12/Statistical-report-of-the-European-Biogas-Association-web.pdf>
- [9] Nicolae Scarlat, Viorel Blujdea, Jean-Francois Dallemand, Assessment of the availability of agricultural and forest residues for bioenergy production in Romania, *Biomass and Bioenergy*, 35(5), 2011, 1995-2005.
- [10] Karthik R. Manchala, Yewei Sun, Dian Zhang, Zhi-Wu Wang, Chapter Two - Anaerobic Digestion Modelling, *Advances in bioenergy*, Volume 2, 2017, Pages 69-141.
- [11] Nicoletta Kythreotou, Georgios Florides, Savvas A. Tassou, A review of simple to scientific models for anaerobic digestion, *Renewable Energy*, Volume 71, November 2014, Pages 701-714.
- [12] M. Fedailaine, K. Moussi, M. Khitous, S. Abada, M. Saber, N. Tirichine, Modeling of the Anaerobic Digestion of Organic Waste for Biogas Production, *Procedia Computer Science*, Volume 52, 2015, Pages 730-737.
- [13] M.A. Martin, R. Fernandez, M. CGUtierrez, J.A. Siles, Thermophilic anaerobic digestion of pre-treated orange peel: Modelling of methane production, *Process Safety and Environmental Protection* 117 (2018) 245–253.
- [14] Dinh Duc Nguyen, Byong-Hun Jeon, Jae Hoon Jeung, Eldon R. Rene, J. Rajesh Banu, Balasubramani Ravindran, Cuong Manh Vu, Huu Hao Ngo, Wenshan Guo, Soon Woong Chang, Thermophilic anaerobic digestion of model organic wastes: Evaluation of biomethane production and multiple kinetic models analysis, *Bioresource Technology* 280 (2019) 269–276.
- [15] European Standard EN 14774, Solid biofuels – Determination of moisture content – Oven dry method, (2009).
- [16] European Standard EN 14775, Solid biofuels - Determination of ash content, (2009).
- [17] European Standard EN 14918, Solid biofuels – Determination of calorific value, (2010).
- [18] European Standard EN 15290, Solid biofuels – Determination of major elements, (2011).
- [19] European Standard EN 15297, Solid biofuels – Determination of minor elements (2011).
- [20] European Standard EN 15104, Solid biofuels – Determination of total content of carbon, hydrogen and nitrogen – Instrumental methods, (2011).
- [21] European Standard 15148, Solid biofuels – Determination of the content of volatile matter, (2010).

- [22] Latinwo, G. K., Agarry, S. E., Modelling the Kinetics of Biogas Production from Mesophilic Anaerobic Co-Digestion of Cow Dung with Plantain Peels, *Int J Renew Energy Develop.*, 4, no. 1, 2015, p. 55-63.
- [23] Krishna Kafle, G., Chen L., Comparison on batch anaerobic digestion of five different livestock manures and prediction of biochemical methane potential (BMP) using different statistical models, *Waste Manag.*, 48, 2016, p. 492-502.
- [24] Lagarias J. C., Reeds J. A., Wright M. H., Wright P. E., Convergence properties of the Nelder–Mead simplex method in low dimensions, *Siam J. Optimiz.*, 9, 1998, p. 112-147.

Session 3.

Designing and Maintenance

TEMPERATURE MAPPING IN PHARMACEUTICAL WAREHOUSE – FRAMEWORK FOR PHARMACY 4.0

Ilija Tabašević¹, Dragan D. Milanović², Vesna Spasojević Brkić², Mirjana Misita²

¹Hemofarm, Vršac, Serbia

²University of Belgrade, Faculty of Mechanical Engineering, Belgrade, Serbia

e-mail: ilija.tabasevic@hotmail.com

Abstract: International Society for Pharmacoepidemiology has recently established a specific interest group Pharma 4.0, with the aim of adjusting the pharmaceutical industry to the Industry 4.0 concept. The aim of this study was to select the best strategy for bringing the temperature mapping in the pharmaceutical warehouses closer to Industry 4.0. For this reason, a temperature mapping was performed. Based on the analysis of the obtained results, a choice of optimal locations for continual monitoring was enabled. The human role herein was overseeing the process and reacting should the process could be disrupted. Progressing towards the Pharma 4.0 concept enabled the control of processes guided by the data from the internal sensors, which will in the future guide HVAC system. Relatedly, the way in which the process of controlling environmental conditions in the pharmaceutical warehouses can be automatized as it is outlined in the paper.

Key words: Pharma 4.0; temperature mapping; pharmaceutical industry.

INTRODUCTION

Industry 4.0 is an original project of the German government, which promotes a strategic approach of production digitalization [1]. Herman et al. [2] define Industry 4.0 through four basic principles: IoT (Internet of Things), IoS (Internet of Service), CPS (Cyber-Physical Systems), and Smart Factory. As one of the most profitable industries, pharmacy had to respond and adapt to the emerging challenges. Therefore, ISPE (International Society for Pharmacoepidemiology) creates a special interest group "Pharma 4.0", in order to bring the pharmaceutical industry closer to the concept of Industry 4.0. Pharma 4.0 represents a transformation of the pharmaceutical industry, which includes the collection and analysis of data through "machines", enabling more flexible and efficient processes [3-5]. As the quality of pharmaceutical products largely depends on storage conditions, the qualification of pharmaceutical warehouses certainly represents a process that needs to be improved and brought closer to the Industry 4.0 concept [4]. As part of the Pharma 4.0 recommendations, ISPE has defined 6 phases of digital maturity (Figure 1), from the phase with the least mature elementary informatization, to the phase with the most mature self-managing, intelligent equipment [4-7]. These phases describe the path taken in this research.

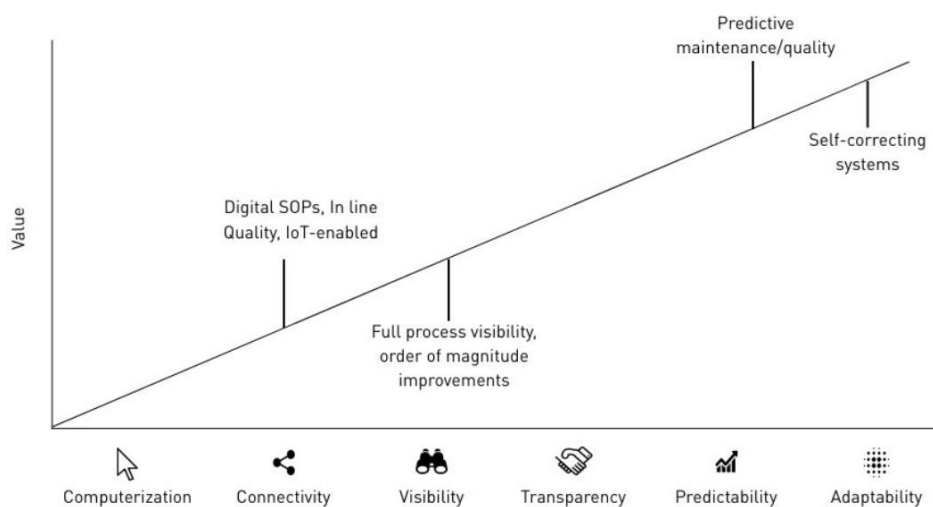

Fig. 1. Stages of digital maturity [7]

Non-compliance with storage conditions is one of the most frequently detected violations detected by regulatory authorities in the pharmaceutical industry during inspections of storage facilities. The most common irregularities concern deviations from the acceptance criteria for ambient conditions, ie. temperature.

Failure to comply with storage conditions can lead to changes in the therapeutic effect of the product, and to harmful effects on the patient's health [8,9]. As temperature deviations are observed during the preparation of raw materials, the production and distribution of pharmaceutical products, a holistic approach to the quality system in pharmaceutical warehouses is needed, which will be based on GMP (Good Manufacturing Practice) and GDP (Good Distributive Practice) [8,9].

The general requirements for the storage of medicines in the pharmaceutical industry, defined by the synonyms "quality system" (GDP and GMP) do not define concise steps for the qualification of the warehouse. Initial temperature mapping, on which we define monitoring positions, cannot prove with certainty the real temperature distribution in the warehouse. The temperature distribution is conditioned by dynamic changes at each point of volume, and represents a very complex thermodynamic task. Li et al. [3] have defined a general methodology for designing wireless sensor networks in order to monitor the production environment in the pharmaceutical plant. Some of their recommendations have been adopted in the research that will be presented in this paper.

RESULTS AND DISCUSSION

Respecting the recommendations, requirements and guidelines established by the relevant regulatory acts [8-13], an experiment of temperature mapping in a pharmaceutical warehouse was performed. Figure 2 shows a diagram of the storage space with the positions where the data loggers are placed. The storage area is $P = 2544 \text{ m}^2$, while the volume is $V = 35616 \text{ m}^3$. The maximum capacity of the storage space is 6782 pallet places. A detailed geometric representation of the mentioned warehouse, as well as the temperature mapping procedure is presented in paper [8]. By collecting and analyzing data, measures for continuous control and monitoring of environmental conditions in real time have been proposed, by which has proven how the qualification process of pharmaceutical warehouses can be further digitized.

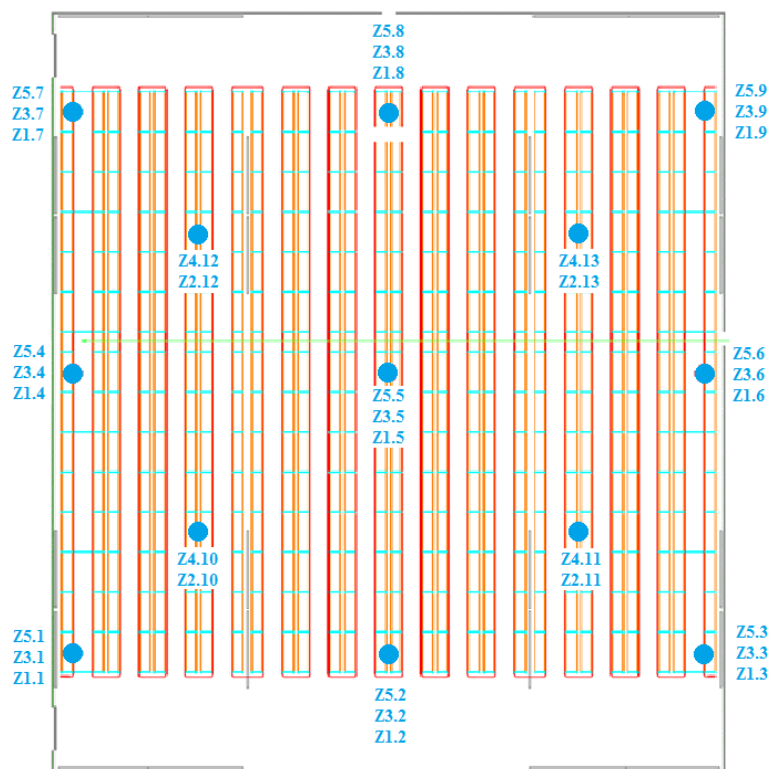

Fig. 2. Data loggers positions

On Figure 2, data loggers are marked in the ZX.Y format where X is the height, and that 1 for data loggers which are set at a height of 1.2 meters from the floor, 2 for data loggers which are set at a height of 3 meters from the floor, 3 for data loggers placed in the central part of the warehouses at a height of 5.5 meters from the floor, 4 for data loggers which are set at an altitude of 8 meters from the floor, and 5 for data loggers placed near the highest storage point, at an altitude of 11.5 meters from the floor. While Y represents the position of the data logger.

Figure 3 shows a graphical representation of the temperature mapping results in the specified pharmaceutical warehouse. In the study conducted in the summer period, 35 data loggers were used, set up according to the scheme shown in Figure 1. Occupancy of the warehouse during the study was ~ 65% (4409 pallets). The temperature mapping test started on July 21, 2017. at 8 p.m., and ended on July 24, 2017. at 8 p.m. The interval between two consecutive measurements was 5 minutes. The outdoor temperature ranged from 20.8 °C to 40.8 °C, while the mean outdoor temperature during the summer mapping period was 30.07 °C.

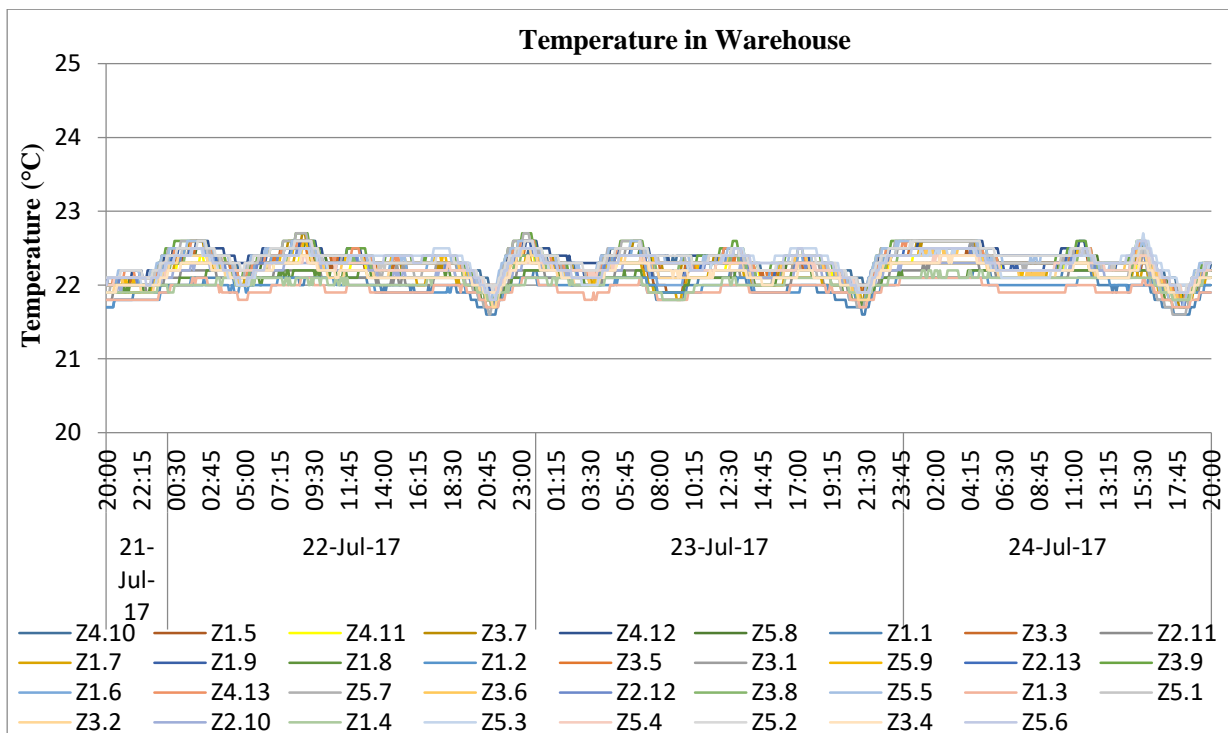

Fig 3. Chart of the data from temperature data loggers

During the execution of the initial study (empty storage), which was shown in paper [8], the temperature ranged from 18.3 °C to 21.3 °C, while in this study (~ 65% filled storage) the temperature ranged from 21.6 °C to 22.7 °C, which shows the dependence of the inertia of the system and the occupancy of the warehouse.

After a detailed analysis of the data, the guidelines and regulations require the defining of critical, "warm" and "cold" points. Defining critical points represents the selection of the best positions for internal sensors for continuous monitoring. After the conducted study in the summer, the recommended positions for continuous monitoring are: Z1.1; Z1.3; Z1.9; Z2.11; Z2.13; Z4.11; Z4.13; Z5.2; Z5.3; Z5.4; Z5.5; Z5.6; Z5.7 and Z5.9. This completes the process of mapping the temperature in the warehouse, and as a result, we get positions for continuous monitoring. For the pharmaceutical industry, meeting the requirements of GMP and GDP is inevitable, and the previously performed process of temperature mapping is more than a sufficient approach to meeting the requirements.

By defining critical points, all requirements of standards and regulations are met. Industry 4.0 strives for complete process automation, so an information system that will independently manage the environmental conditions in the warehouse will be proposed below.

Part of the automatic control system is the BMS (Building Management System) as a homogeneous system that collects monitors and stores both critical and non-critical data from the field. Values of all sizes from the project are available on the BMS computer. The concept of this system is to connect physical quantities from the process in three levels: **The peripheral level** consists of all sensors connected to the system on the object, all measurements of temperature, humidity, pressure, operating status, failure, etc.

The controller level consists of all controllers with their distributed modules. In the field of each cabinet there are I/O - modules for accepting the sizes collected in the field. Each of the modules placed in the automation cabinets accepts signals of a certain type. Distributed modules communicate via internal serial P-BUS communication with the controller. All controllers on the high-rack warehouse facility are modular free-programming controllers of the PXC100-D type. The controllers are interconnected in the LON network and communicate with the BACnet protocol.

The BMS level makes up the highest connection level at the high-rack warehouse facility. At this level is the Desigo Insight V5.1 central monitoring and control system. It represents the basic graphical interface to the user. The connection between the controller and Desigo Insight V5.1 is made via the PXG80-N router. The complete topology is shown in Figure 4.

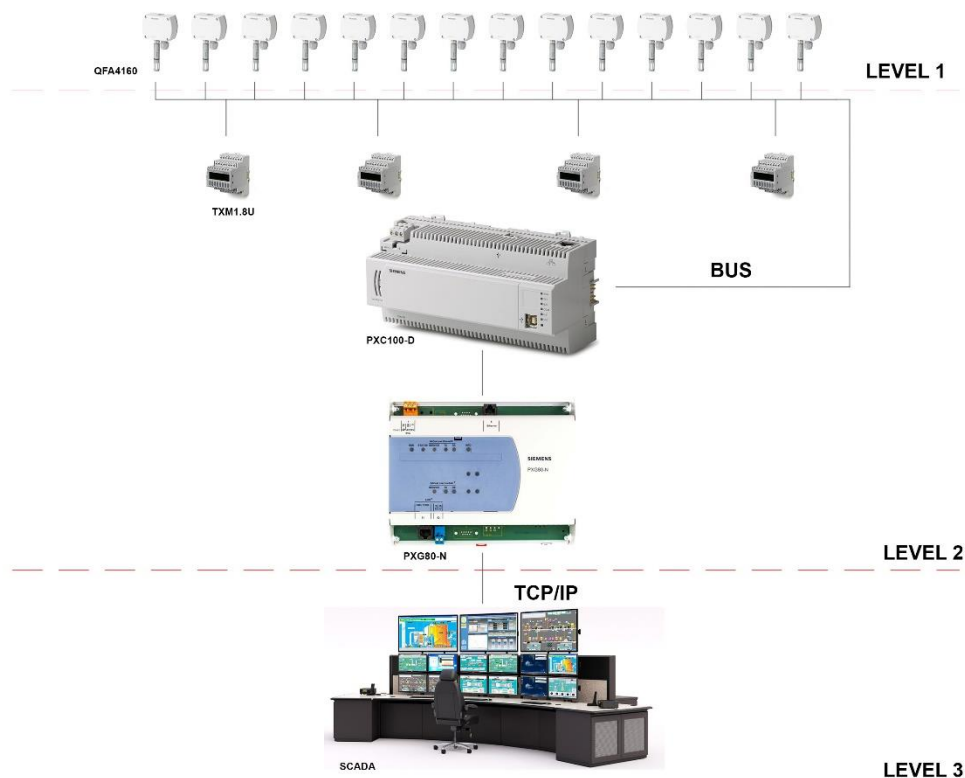

Fig 4. Architecture of distributed control system

With the adoption of the proposed information system, the process of controlling the environmental conditions in the warehouse will be fully automated. BMS collects data from all 14 internal sensors (whose locations are determined by temperature mapping), calculates their mean value and forwards such defined information to the air conditioning system. This enables process control guided by data from internal sensors, which will in the future "guide" the air conditioning system, and shows how the process of controlling environmental conditions in pharmaceutical warehouses can be automated.

CONCLUSION

Although Industry 4.0 represents a progressive leap from traditional automation to a fully integrated and flexible system, the application of these systems in the pharmaceutical industry has not been examined in detail. To reap the benefits, Pharma 4.0 requires further process research, from raw material procurement to distribution to end users. The paper shows how the qualification process of pharmaceutical warehouses could be brought closer to Industry and Pharma 4.0 concepts. Described experiment shows the possibility of defining the optimal number of locations for continuous monitoring, without affecting the quality of drugs which are stored. With the introduction of internal sensors, control of the air conditioning process guided by real-time data is enabled. In addition to continuously providing process control, the ability of analytical data to detect deviations from the required eligibility criteria in a timely manner is very important. Pharmacy is one of the most regulated branches of industry, so this "evolution" should be a great opportunity to demonstrate access and adaptation to digitalization, with the necessary condition that regulatory frameworks become more accessible and open.

REFERENCES

- [1] Barenji, R. V., Akdag, Y., Yet, B., & Oner, L. (2019). Cyber-physical-based PAT (CPbPAT) framework for Pharma 4.0. *International journal of pharmaceutics*, 567, 118445.
- [2] Hermann, M., Pentek, T., & Otto, B. (2016, January). Design principles for industrie 4.0 scenarios. In 2016 49th Hawaii international conference on system sciences (HICSS) (pp. 3928-3937). IEEE.
- [3] Li, W., & Kara, S. (2017). Methodology for monitoring manufacturing environment by using wireless sensor networks (WSN) and the internet of things (IoT). *Procedia CIRP*, 61, 323-328.
- [4] Ding, B. (2018). Pharma industry 4.0: Literature review and research opportunities in sustainable pharmaceutical supply chains. *Process Safety and Environmental Protection*, 119, 115-130.
- [5] Pyatigorskaya, N. V., Beregovykh, V. V., Belyaev, V. V., Greibo, S. V., & Pyatigorskiy, A. M. (2018). Rationale for the Necessity of Temperature Mapping Of Storage Areas for Pharmaceutical Products. *Journal of Pharmaceutical Sciences and Research*, 10(3), 662-664.
- [6] Herwig, C., Wölbeling, C., & Zimmer, T. (2017). A holistic approach to production control: From Industry 4.0 to Pharma 4.0. *Pharm. Eng*, 37, 44-46.
- [7] Binggeli, L., Heesakkers, H., Woelbeling, C., & Zimmer, T. (2018). PHARMA 4.0: Hype or Reality?. *Pharmaceutical Engineering*. <https://ispe.org/pharmaceuticalengineering/july-august-2018/pharma-40tm-hype-or-reality>. Published July/August. Accessed August 28,2020
- [8] Kumar, N., & Jha, A. (2017). Temperature excursion management: A novel approach of quality system in pharmaceutical industry. *Saudi Pharmaceutical Journal*, 25(2), 176-183.
- [9] Milanovic, D. D., Tabasevic, I., Misita, M. (2018). The managing of the temperature mapping process of the warehouse. XVI International Symposium Doing business in Digital Age, Symorg, University of Belgrade FOS, 1002-1010.
- [10] Health Products Regulatory Authority. Guide to Good Distribution Practice of Medicinal Products for Human Use Guidelines for good practice in distribution, Official Gazette of the Republic of Serbia, no. 30/10 and 107/12, 2016.
- [11] ISO IEC 17025:2017, General Requirements for the Competence of Testing and Calibration Laboratories. International Organization for Standardization, Geneva, 2017.
- [12] WHO Technical Report Series No. 961, 2011, Annex 9: Model guidance for the storage and transport of time and temperature-sensitive pharmaceutical products – Qualification of temperature-controlled storage areas. Geneva: World Health Organization; August 2015: Annex 9.
- [13] WHO Technical Report Series No. 961, 2011, Annex 9: Model guidance for the storage and transport of time and temperature-sensitive pharmaceutical products – Checking the accuracy of temperature control and monitoring devices. Geneva: World Health Organization; May 2015: Annex 9.

CLUSTER AS A MODEL OF ENTREPRENEURIAL INFRASTRUCTURE

Vlado Medaković¹, Bogdan Marić¹

¹University of East Sarajevo, Faculty of Mechanical Engineering East Sarajevo, East Sarajevo, Bosnia & Herzegovina

e-mail: vlado.medakovic@ues.rs.ba, maricbogdan@ues.rs.ba

Abstract: The paper presents one way of support to small newly established enterprises and entrepreneurs, which are in a development life phase, is the system of technological infrastructure. Those are different organizations which help entrepreneurs to develop their business ideas and to overcome more easily the initial problems in business, for which, in a wider context, the term business incubators is used, and also the clusters related to entrepreneurs who are in an advanced phase of entrepreneurship.

The paper presents the general characteristics of entrepreneurial infrastructure - clusters. We present in the table existing organizational forms of business infrastructure (clusters), their activities, and numerical strength in the territory of the Republic of Srpska.

Key words: SMEs, Entrepreneurial infrastructure, Clusters, Entrepreneurship

INTRODUCTION

Infrastructure is important for entrepreneurial activities [4] and may have various forms and functions. As first, the development of trade and industrial growth require physical infrastructure, road and railway traffic and transportation etc.

In all developed Western countries and in many developing countries, entrepreneurship and small enterprises as a whole are supported by the state, state institutions and nongovernmental organizations in many ways [7,9].

Orientation of a market-developed countries has deep roots, regarding the fact that the capitalism has tried many development models as opposed to one-dimensional models of economic flows control which have been practiced more-less for decades in the countries of socialist and similar socio-economic systems.

The support to the development of small and medium-sized enterprises in the Republic of Srpska had gained in importance in 2002, with the adoption of the Program of Small Business Development, and after that the Law on Stimulating the Development of Small and Medium-sized Companies was adopted. The adopting of the Law has created the basis for legislative, institutional and financial help to this area.

On the basis of the Law, during 2004, there were formed: Department for SMEs and Production Craftsmanship at the Ministry of Economy, Energy and Development of the Republic of Srpska and the Republic Agency for the Development of Small and Medium-sized Enterprises. At the same time, on a local level, local agencies for the development of SMEs were being established. The support to the development of SMEs at a local level is also given by municipal development departments which, together with the above mentioned institutions, make support network for the development of SMEs.

Similarly to the leading countries of the West, many small countries which started with the implementation of market-capitalistic principles in the development of economy three to five decades ago, have reached an enviable level of development today [7] exactly due to the development of small enterprises.

The determinations of Bosnia and Herzegovina [2] related to the SMEs development sector rely on the recommendations of the European Charter and the Act on Small Business. The Law on Ministries and Other Control Bodies of Bosnia and Herzegovina has also defined the institutional framework in the field of issues in the sector of SMEs whose difficulties reflect, above all, in: approaches in defining policies, development strategies and goals in the sector of SMEs, competences, way of work a harmonized monitoring of the results in this area, mutual cooperation and profitability and excessive administration.

At the level of the Republic of Srpska, within the Ministry of Economy, Energy and Development, there is a department for small and medium-sized enterprises, the head of which is an assistant

minister with the responsibilities in the work fields: development of entrepreneurship and craftsmanship, making of medium-term and long-term development plans and making of the development strategies of SMEs and entrepreneurial activity.

Pursuant to the [12], an enterprise is a legal person which performs the activity to gain profit, and an entrepreneur is a physical person who performs the activity to get profit and the activity of free profession, while an individual agriculturist is not an entrepreneur. The Law does not know the notion of small and medium-sized enterprise, and because of that the same provisions apply to them as to the other enterprises.

The new [13] is a modern regulation, greatly harmonizes with the directives of the European Union company law and as such should contribute to the creation of a legal framework complementary the internal market of the EU.

The Law on Business Companies of the Republic of Srpska is based on the best solutions of modern national law of the surrounding countries, and also of some countries from Europe and the USA (Illinois), the Statute of the European Company from 2001, OECD Principles of Corporate Governance from 1998 etc. Entrepreneurship, in the sense of the [14], is an innovative process of creation and development of business ventures or activities and of creation of business success at market. Entrepreneurial infrastructure presents spatial-technical forms for toe support of entrepreneurship development, with a special emphasis on establishing and development of SMEs.

Entrepreneurship, in the sense of The Law on Development of SMEs of the RS, is an innovative process of creation and development of business ventures or activities and of creation of business success in the market. Entrepreneurial infrastructure presents spatial-technical forms to support entrepreneurship development, with a special emphasis on establishing and developing SMEs.

In recent time [3], there is a greater emphasis in the commercialization of university research, especially through the creation of spin-off enterprises. They emphasize inhomogeneity of the concept of university spin-off enterprises and point out their heterogeneous properties.

CHARACTERISTICS OF CLUSTERS

A cluster is a network organization or a group of enterprises coordinated by market mechanisms [7,9] rather than by chains of commands. A cluster consists of enterprises that are mutually connected, vertically (buyer – supplier) or horizontally (same buyers, technologies, distribution etc.). Competitive branches are grouped into clusters most often.

A cluster [14] is a form of entrepreneurial infrastructure consisting, in a geographical area, of mutually related business entities that do their business in the same, similar and various activities and, related to them, specializes suppliers, service providers, educational and scientific-research institutions, agencies and other.

In the practice of small-enterprise development, the cluster model deserves special attention. It has proven to be practical, especially in countries that have a tradition of supporting the development of small enterprises. The immediate predecessor to the development of clusters was incubators and, actually, clusters developed quickly in the areas that have had experiences with incubators. The connecting of entrepreneurs, their cooperation, sharing of services and equipment, or their networking into the most common clusters is also, as stated by [1], the influence of the work of most incubators. The connecting of business incubators with the academic and research community is also of great significance.

Clusters are presented by[11] as the basis of the new competitive economy, emphasizing their importance in increasing the competitiveness of enterprises on local and international markets. He defined them as geographic concentrations of mutually related enterprises, specialised suppliers, service providers, enterprises with similar activities and relevant institutions related to them (universities, agencies for standardisation and vocational associations), which mutually compete in some areas but also earn money. A cluster, as a concentration with critical mass [11] and extraordinary competitive success in a certain activity, represents a significant characteristic of every country, regional and local economy, especially in economically developed countries.

In countries in transition, clusters have their real future perspectives. It must be kept in mind that the experiences gained in the development of clusters in the European Union can be transferred to local practice without modifications, which would be unavoidable in an uncontrolled development.

The system of clusters [6] is a global model for the development of small enterprises. They prosper where the development of small business has already reached a significant level and where systematic measures of the country contribute to it. They assist enterprises to develop quickly, to apply modern methods of work and gain the maximum from their market environment under modern management; at the same time, the regional economy achieves competitive advantages in relation to others. Thus clusters connect technologies, industries and, generally, the economies of two regions or even a few regions from a few countries.

It can occur within branches (metal, wood, textile, food etc.) in which SMEs develop by using communications, technologies and foreign investments from other regions.

The aim of clusters is to achieve a competitive advantage. One of the relevant factors promoting competitiveness is also the geographic concentration. Finally, besides the geographic (local) factors, legislation, organization and development of financial market have great significance for the development of clusters. The use of knowledge [8] about sound strategies for the development of clusters in the world and on the overall results from their realization contributes so that, in all new cases (either specific or not), good solutions for their creation and development are established.

However, besides the similarities, there are also differences in the development of clusters. They mostly occur due to different degrees of development of regions, levels of governmental inclusion in this model of small enterprises development, strengths of the industrial basis, critical masses of people with entrepreneurial spirit and the general interest of environment factor carriers in general. In developed countries, local and regional government initiate the development of clusters and have had success in that, because of good knowledge of economic processes and of exactly where they are in control, consistent with finding productive measures of support for the realization of the goals [10]. In underdeveloped countries and in small countries, ventures of this type are taken at the national level, especially when it is known that local and regional authorities are not ready to support the development of clusters.

REVIEW OF EXISTING FORMS OF ENTREPRENEURIAL INFRASTRUCTURE – CLUSTERS IN THE REPUBLIC OF SRPSKA

At the beginning of the 1990s, characterized by the breakdown of the former state, the outbreak of civil war, especially in the territory of B&H (The Republic of Srpska), events stopped not only the development of entrepreneurship but also fundamental economic activities. The support for development of small and medium-sized enterprises in the Republic of Srpska gained in importance in 2002, with the adoption of the Program of Small Business Development, and, after that, the Law on Stimulating the Development of Small and Medium-sized Companies was adopted. The adopting of the law created the basis for legislative, institutional and financial help in this area. On the basis of the law, during 2004, there were formed two key agencies: the Department for SMEs and Production Craftsmanship at the Ministry of Economy, Energy and Development of the Republic of Srpska and the Republic Agency for the Development of Small and Medium-sized Enterprises. At the same time, on for local level, local agencies for the development of SMEs were being established. The support the development of SMEs at the local level is also now given by municipal development departments which, together with the above mentioned institutions, maintain support network for the development of SMEs.

Besides the state institutions, the institutes for small business at universities and colleges have a significant role in the support of the SME sector in the USA [9,10].

In the European Union, state institutions also support the work of SMEs, creating a favourable setting for their business. The development of SMEs in the EU occurs at various levels, although the measures are not harmonised and the same for all members, which implies that a successful practice cannot be copied because of the existence of differences in cultures, economic structures and economic potentials.

Every local community or a set of local communities that are connected geographically engages in various activities to improve the conditions of work for SMEs so as to attract a larger number of enterprises to their territory or their region [9,10]. Local communities plays a very significant role, while the task of the country, or the government, is to activate the internal resources, as additional developmental sparks.

A prudent activity of a local community aiming to develop its own infrastructure and entrepreneurial potential and to attract investments can be to adopt a concept for regional development. Local communities must develop attractive environments for capital and enterprises.

The establishment of business zones accelerates and simplifies the placement of spatial resources in the function of economic development, investments, growth and employment. Everywhere in the world, business zones present a significant instrument for the stimulation and development of entrepreneurship and general economic growth of an area. They are established on the basis of a clearly expressed interest among the businessman and bodies of local and regional government, with the support of higher levels of government and research-educational organizations, universities and institutes.

Regarding the business incubators, their location is also important, and it is recommended that an incubator serve as an entrepreneurial environment, so it is desirable that they be networked with the university or science sector. Incubators accept [10] primarily firms based on new technologies (hi-tech firms) or production firms based on tested technologies. The emphasis should be put on human factor as the generator of success. Business incubators, as well as business zones, can have a significant, positive impact on the development of the national and local or regional economy. The entrepreneurial infrastructure [14] can be organized in the form of business zones, technology parks, entrepreneurial incubators and clusters. Exceptionally, they can be organized and other forms of infrastructure for the development, promotion and research in this area in accordance with the regulations and requirements of the economy. Table 1. Review of existing forms of entrepreneurship infrastructure- clusters in the Republic of Srpska [5] provides an overview of the entrepreneurial infrastructure in the Republic of Srpska. This overview contains the forms of organization of entrepreneurial infrastructure clusters.

As regards cooperation with scientific institutions and universities in the Republic of Serbian, there exists several business incubators and one cluster; they are: Existing clusters are Solar Energy Cluster, whose is activities Energy, gas and water production and supply. Leader cluster is Faculty of Mechanical Engineering Banja Luka with members “Topling Factory” Prnjavor, “Energomont – Bemind” Banja Luka and “Koming pro” Gradiska.

Table 1 Review of existing forms of entrepreneurship infrastructure- clusters in the Republic of Srpska

Entrepreneurial infrastructure		Activities	Numerical strength
Cluster	Existing clusters	Agriculture and forestry	5
		Processing and products of wood and cork, cellulose paper and paper products	6
		Energy, gas and water production and supply	1
		Food and beverage industry	1
		Other	2
	Planned	Food and beverage industry	1
		Agriculture and forestry, food and beverage industry	1
	Cooperatives	Food and beverage industry	4
		Agriculture and forestry, food and beverage industry	6

CONCLUSION

Every local community or a set of local communities which are connected geographically, to attract a larger number of enterprises to their territory, the territory of the Region, takes various activities to improve the conditions of work of SMEs.

Local community plays a very significant role, while the task of the country, or the government, is to activate the inner resources, as additional development impulses. A prudent activity of local communities with the aim of developing own infrastructure and entrepreneurial potential and attracting of investments can be a concept of regional development. Local community must develop an attractive environment for capital and enterprises.

The current determination is to harmonise the legal framework, which is being built with the EU and the Act on Small Business, providing the conditions for the SMEs sector to be at the top of economic development priorities.

It is very important to make efforts in understanding particular notions of different forms of entrepreneurial infrastructure. There are no precise and unified definitions, so the matching is not compulsory among the notions in the various countries.

General characteristics of entrepreneurial infrastructure (clusters) are presented, as well as their role and importance in terms of providing conditions for the creation and development of small and medium enterprises.

The paper presents the existing state of the clusters in the Republic of Srpska, with the numerical strength, as well as their activities.

From the point of view of activities and the impact of scientific institutions and universities in the Republic of Srpska and their participation in establishing and supporting the work of the cluster, the results are not satisfactory.

We have a cluster in which participates as a founder the Faculty of Mechanical Engineering Banja Luka.

REFERENCES

- [1] Bošnjak S., Business incubators as generators of entrepreneurship development. *Practical Management. J Theory Appl Manag*, Vol. 2, No. 2, pp. 51–56, 2011.
- [2] Cvijić M., Istraživanje uslova i mogućnosti za razvoj preduzetništva u procesu tranzicije. doktorska disertacija. Novi Sad, 2007.
- [3] Garmendia B.M., Castellanos R.A., Types of spin-offs in a university context: a classification proposal. *Cuadernos de Gestión* Vol. 12, No. 1. pp. 39-57, 2012.
- [4] Heger D., et al., The Effect of Broadband Infrastructure on Entrepreneurial Activities: The Case of Germany. Centre for European Economic Research (ZEW). 2011.
- [5] IRB RS, URL: www.irbrs.net.
- [6] Jojić R, Božić R, Entrepreneurship for the new century. Srpsko Sarajevo, Priština, 1998.
- [7] Medaković V., Research of conditions for development of small and micro enterprises and development of entrepreneurial infrastructure model. Doctoral thesis. Faculty of Mechanical Engineering. East Sarajevo, 2012.
- [8] Medaković V, Marić B, Gojković R., Cluster as a model organization for small and medium-sized enterprises. 3rd International scientific conference "Conference on mechanical engineering technologies and applications" COMETA 2016. East Sarajevo, pp 517–522, Jahorina 2016,
- [9] Medaković V, Marić B, Moljević S, Miljanović M, Gojković R., Entrepreneurial infrastructure—characteristics of business zones. In: VI International conference industrial engineering and environmental protection 2016 (IIZS 2016). pp 8–13, Zrenjanin 2016.
- [10] Medaković V, Marić B., Characteristics of business incubators. In: IX International conference industrial engineering and environmental protection 2019 (IIZS 2019). pp 279–284, Zrenjanin 2019.
- [11] Porter ME, Clusters and the new economics of competition. *Harvard Business Review*, pp 77–78, New York 1998.

- [12] The Law on Enterprises of the Republic of Srpska (2006) Gazette RS. Number 24/98. 62/02. 38/03. 97/04 and 34/06.
- [13] The Law on Business Companies of the Republic of Srpska (2008) 01-1882/08. Gazette RS. Number 127/08.
- [14] The Law on Development of SMEs of the Republic of Srpska (2013) 01-916/13.

MATHEMATICAL MODEL OF OPTIMIZATION OF VIBRO-DIAGNOSTICS PROCEDURES

Milica Josimovic¹, Ljubisa Josimovic², Slavica Prvulovic¹, Vladimir Šinik¹

¹University of Novi Sad, Technical Faculty "Mihajlo Pupin", Zrenjanin, Serbia

²High Textile School, Leskovac, Serbia

e-mail: prvulovicstavica@yahoo.com

Abstract: This paper intends to present the elaborated mathematical model containing determinations of links between periodicity changes of parameters for circuit components and signaling tolerance of parameters for condition of components when securing given condition of components. This model launches direct relations between reliability and regularity of parameter change for condition of observed circuit component and it has direct task to determine output characteristics of the model: time of first condition check, allowed value of condition parameters and signaling tolerance for condition parameters and their limitations where is mandatory to perform procedures for preventive maintenance in order to avoid failure of components.

Key words: Mathematical model, optimization, turbo-generator, maintenance, vibro-diagnostics, reliability, temperature, time, allowed value, condition parameter, tolerance.

INTRODUCTION

Arithmetic mean value random functions $A(t)$ is calculated according to the following e Universal model of the program package automatically resolves mathematical-model interpretation of the process of monitoring parameters of components and it gives output characteristics that represent the base optimal monitoring of procedures in the processes for turbo-generator condition change, determination and performance of preventive maintenance procedures [1]. Conducted spectral analyses of random functions will be determined by basic statistical diagnostic parameters that describe character of random functions, and it is of critical importance for the safety model analysis of functioning of analysed turbo-generator circuits [2, 3].

In the conducted measurement analysis, the amplitude and frequency values at the selected measuring points were measured for a duration of 10 minutes, for each measurement of 2 minutes. This refers to the amplitude dependency records from the measurement time. The measurements were carried out in the precisely predicted intervals of the components of the analyzed assemblies at the time of analyzing their work from 40000 - 60000 hour.

The explicit dependence of determining the mean amplitude by the spectral analysis of random functions, for the measurements carried out in the precisely determined exploitation work of the assembly and at the precisely determined measuring point.

This repeat of the measurement aims to determine the more precise values of the oscillation amplitudes in order to determine their mean values of a mean amplitude that is valid as the size in the analysis of the optimal model of component safety of the components assemblies.

MATERIAL AND METHODS

Measurement analysis procedure

Main statistical diagnostic parameters that analyse the value of turbo-generator condition represent the arithmetic average value p_A (average arithmetic dependence of oscillation amplitude) on the measurement spot in expression ¹ [1]:

$$A_{i,n} = p_A = \lim_{n \rightarrow \infty} \frac{1}{N} \sum_{i=1}^n A_i(t) \quad (1)$$

where is:

i - number of measurement points,

n - number of component components of turbo generator,
 N - number of equal time sub-fans (t_i) the duration of random functions,
 $A_i(t)$ - the amplitude values of random functions in the observed duration (t_i)
 at selected measuring points.

The frequency amplitude values are dependent on the function $f = f(A_i)$ and duration (t_i), and for the analysis of random functions, a sufficiently large time interval is adopted, which is then divided into an equal number of intervals $\Delta t = \frac{t}{N}$.

The explicit dependence of determining the mean amplitude is expressed as follows [4]:

$$A_{i,n} = p_A = \lim_{n \rightarrow \infty} \frac{1}{3} [A_1(t) + A_2(t) + A_3(t)] \quad (2)$$

where they are $[A_1(t), A_2(t), A_3(t)]$, the amplitude values at the selected measuring location of the circuit, for three repeated measurements, because of the more accurate measurement results.

Table 1. Mean values of the amplitude for measuring the measuring points TEKO A (TE Kostolac) and the duration without applying the state parameter control

Observed area	Allowed risk			Risk		Repair
T	44000	48480	56160	44800	54720	>60000
$A_1(t)$	8,0112	7,8888	7,9	8,1888	8,1888	8,7664
$A_2(t)$	7,956	7,928	7,9248	7,9912	8,1584	8,5912
$A_3(t)$	8,5632	8,5632	8,3952	8,3312	8,3296	9,1296

Tables 1 and 2 show the optimal operating mode with the best reliability and the permissible risk, an overview of the calculated mean amplitude values $A_k(t)$ depending on the exploitation time of operation (t) components of assemblies at precisely defined measuring points for three consecutive measurements for each interval of said exploitation time of the components of the components $t_i(h)$.

Table 2. Mean values of the amplitude for measuring the measuring points TEKO A and the time duration with the application of the component parameters state control (TE Kostolac)

Observed area	Allowed risk			Risk		Repair
t (h)	44000	48480	56160	44800	54720	> 60000
$A_1(t)$	7,5696	7,6656	7,6928	7,8736	7,9296	8,5184
$A_2(t)$	7,4992	7,5952	7,6688	7,768	7,888	8,7168
$A_3(t)$	7,8512	8,0208	8,0576	8,0112	8,0288	8,7168

The reliability of the work of the constituent components of the analyzed assemblies depends directly on the amplitude values at the analyzed measuring points and the correlation of their reciprocity is required. Since the relevant reliability of the work of the analyzed assemblies is determined based on the selected statistical distribution, it is necessary to connect these parameters, respectively, to determine their dependence on the correlation of the connection.

Functional dependence between double peak amplitudes $2A(f_0)$ measured in [μm] and the power of the generator P_A u [MW] can be mathematically presented using the equation ² [1]:

$$2A(f_0) = f(P_A) \quad (3)$$

The most adequate dependence is the approximation by linear regression or the polynomial of 5th grade for measuring the number 1 and 3 and the 4th degree of measurement for the number 2 and 3. In order to generalize the solution, this dependence is chosen in the form of a 4th degree polynomial and represents the optimization model.

The analysis covered the 4th degree polynomial with real coefficients (a_1, a_2, a_3, a_4) , and if it comes from the general form of the representation of the real polynomial n-th of the degree in the record [5]:

$$f(x) = a_n x^n + a_{n-1} x^{n-1} + \dots + a_1 x + a_0 \quad (4)$$

where is:

a_{0-n} - coefficients of real polynomial,

x^n - parameters of component state change.

Where they are $a_i \in J$, $i = 0, 1, 2, 3, \dots, n$, and $n \in N$, then it is called a polynomial with real coefficients which is used as a basis in the analytical determination of a higher degree of polynomial.

The value of the analytic polynomial of the 4th degree with the n-th degree polynomial will be:

$$(Q - J)(t) = +a_4 A^4 + a_3 A^3 + a_2 A^2 + a_1 A + a_0 \quad (5)$$

where is:

$(Q - J)(t)$ - polynomial with real coefficients that give dependence of reliability in function of component values,

A_i^n - the amplitude values at the selected measuring points,

a_i - real coefficients of state component parameters.

For the determination of their real parameters, a system of equations in the general form will be set, which includes the coordinate values of the points that determine this dependence [2]:

$$\begin{aligned} a_4 A_1^4 + a_3 A_1^3 + a_2 A_1^2 + a_1 A_1 + a_0 &= N^1 \\ a_4 A_2^4 + a_3 A_2^3 + a_2 A_2^2 + a_1 A_2 + a_0 &= N^2 \\ a_4 A_3^4 + a_3 A_3^3 + a_2 A_3^2 + a_1 A_3 + a_0 &= N^3 \\ a_4 A_4^4 + a_3 A_4^3 + a_2 A_4^2 + a_1 A_4 + a_0 &= N^4 \\ a_4 A_5^4 + a_3 A_5^3 + a_2 A_5^2 + a_1 A_5 + a_0 &= N^5 \end{aligned} \quad (6)$$

The determinant of system D is:

$$D = \begin{vmatrix} A_1^5 A_1^4 A_1^3 A_1^2 A_1 \\ A_2^5 A_2^4 A_2^3 A_2^2 A_2 \\ A_3^5 A_3^4 A_3^3 A_3^2 A_3 \\ A_4^5 A_4^4 A_4^3 A_4^2 A_4 \\ A_5^5 A_5^4 A_5^3 A_5^2 A_5 \end{vmatrix}$$

The determinant of system D_1 is:

$$D_1 = \begin{vmatrix} A_1^5 A_1^4 A_1^3 A_1^2 A_1 \\ A_2^5 A_2^4 A_2^3 A_2^2 A_2 \\ A_3^5 A_3^4 A_3^3 A_3^2 A_3 \\ A_4^5 A_4^4 A_4^3 A_4^2 A_4 \\ A_5^5 A_5^4 A_5^3 A_5^2 A_5 \end{vmatrix} \quad (7)$$

The real coefficient of the polynomial parameter is obtained: $a_4 = \frac{D_1}{D}$, and the other coefficients are obtained by replacing the corresponding columns of determinants with a column that includes reliability:

$$a_3 = \frac{D_2}{D}, \quad a_2 = \frac{D_3}{D}, \quad a_1 = \frac{D_4}{D}, \quad a_0 = \frac{D_5}{D}. \quad (8)$$

In order to get as much as possible the values of the coefficients of the polynomial $(a_4^1, a_3^1, a_2^1, a_1^1, a_0)$ in relation to those obtained by analytical approach, the programming of obtaining real polynomial coefficients using a mathematical program MATLAB.

Obtaining the exact value of real coefficients as well as drawing the correlation dependency graphic was done in the mathematical program MATLAB. in the following way:

$$x = [A_1^1(t)_{A_5} A_1^2(t)_{A_5} A_1^3(t)_{A_5} A_1^4(t)_{A_5} A_1^5(t)_{A_5}] \quad (9)$$

$$y = [N_{A_5}^1(t) N_{A_5}^2(t) N_{A_5}^3(t) N_{A_5}^4(t) N_{A_5}^5(t)] \quad (10)$$

```
% degree of polynomial approximation
n = 1.....5
% vector r contains coefficients of degree polynomials n
r = (x,y,n)
% displaying the values to be approximated and
% polynomial that approximates
x1 = A1^1(t)A5 : 0,01 : A1^5(t)A5 ;
y1 = (r, x1);
plot (x1, y1, x, y, '*');
```

In order for a mathematical model to be applied it is necessary to table the dependencies of the changes in the parameters of the state in operation $A_i^{n=1, \dots, 5} = f(N_1^{i=1, \dots, 5})$ of the value of reliability (J_{i-e}) in the exploitation time period of the performed measurements, tables 3 and 4.

Table 4. Reliability values of the real coefficients of the polynomial parameter in the function of the value of the circuits TEKO A, without applying the component parameters state control

Components of circuits	Code of coefficients				
	a_4^i	a_3^i	a_2^i	a_1^i	a_0^i
N ₁	0	0	0	-0,1728	0,9464
N ₂	0	0,06872	0	0	0
R ₁	0,00008	0,00672	0,07568	1,70896	0
N ₃	0	0,0064	0,06528	0,43304	-1,81136
N ₄	0	0,00216	0,02568	0,2384	0,98768
N ₅	0	0,00288	0,03328	-0,1537	0,9872
N ₆	0	0,00168	0,0808	0,56368	2,25408
N ₇	0	0	0	0,52408	0,8
N ₈	0	0	0	0.51022	0,7456

Table 5. Reliability values of the real coefficients of the parameter of the polynomial in the function of the value of the work of the TE Kostolac circuits, with the application of the component parameters state control

Components of circuits	Code of coefficients				
	a_4^i	a_3^i	a_2^i	a_1^i	a_0^i
N ₁	0,4368	0,00328	0	0	0
N ₂	0,02616	0,01704	0,88592	0,67688	0
R ₁	0	0,00712	0,10192	0,07496	0
N ₃	0	0,00648	0	0	0
N ₄	0,02136	0,00432	0	0	0
N ₅	0,0276	0	0	0	0
N ₆	0,042238	0,00312	0,78528	0,2916	0,06432
N ₇	0	0	0	0	0,73312
N ₈	0	0	0	0	0,6913

RESULTS AND DISCUSSION

Allowed risk of mechanical vibrations

The construction of the diagram is based on the reliability value for the area of the permissible risk and the mean values of the mechanical vibration amplitudes at the selected measuring points (Figures 1, 2, 3). These reference curves show the optimum value of the correlation of dependency and can be

verified at each point in the reliability value, whether the same approximate curve is at the specified point or is scattered. Based on such an analysis, it is necessary to apply the status parameters of the component or to perform the overhaul of the component [6, 7].

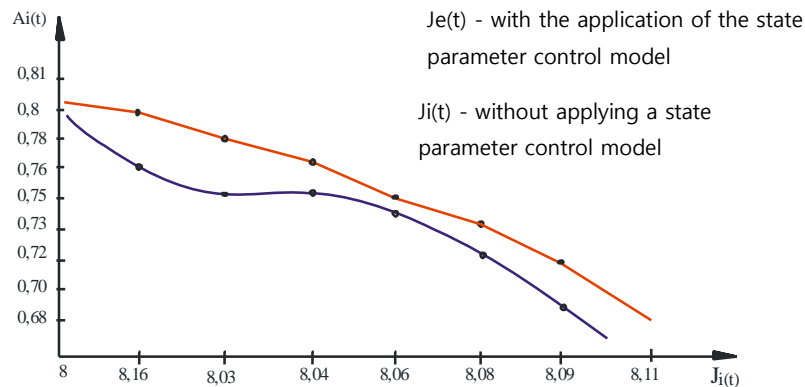

Fig. 1. Diagram of dependence of reliability in oscillation amplitude function for measuring point 1, without and with the application of control parameters of the components of the TE Kostolac

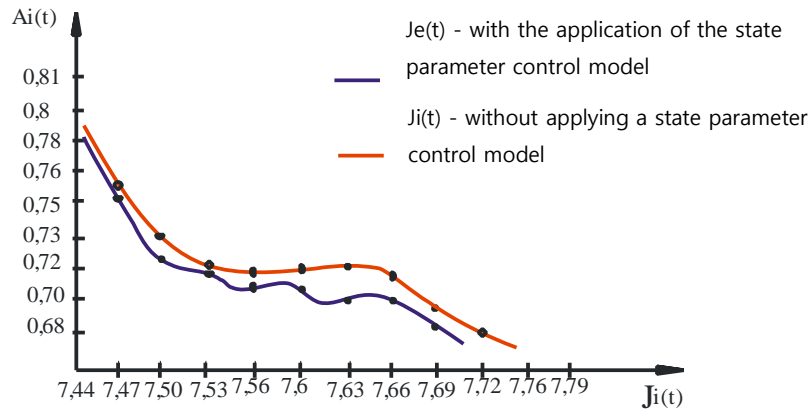

Fig. 2. Diagram of dependence of reliability in oscillation amplitude function for measuring point 2, without and with the application of control parameters parameters of the components of the TE Kostolac

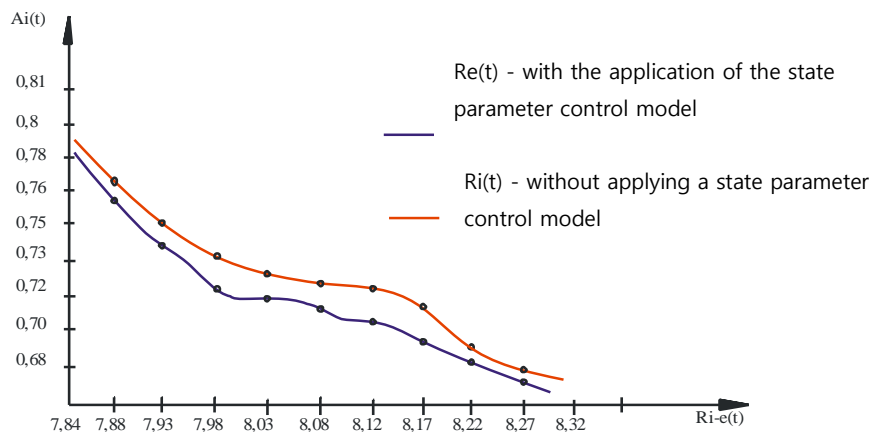

Fig. 3. Diagram of dependence of reliability in oscillation amplitude function for measuring point 3, without and with the application of control parameters parameters of components 0of TE Kostolac

Determining the diagnostic parameters is reduced to the quantities with known laws from the theory of probability. The model determines the functional dependence of the double peak amplitudes of the turbine and generator shafts [2].

Forming the universal optimal model of vibrodiagnostics

In order to form a universal optimal model of vibrodiagnostics it was necessary to determine all the listed parameters of theoretical and exploitation analysis (which are determined by analytical or experimental way), and then connect them to the mathematical form. This was done analytically in the form of portable functions of an optimal model $O_{\eta}(t)$ which will define the operation of the analyzed turbogenerator components.

The model analysis was carried out stepwise, in determining the submodel according to the selected measuring points for determining the level of mechanical oscillations, and then the structure of the block diagram of the submodule connection.

When solving this model, the reduction will be achieved in obtaining the optimal reliability function $H_p(t)$.

The model block diagram of the reliability of the constituent components is shown in Figure 4.

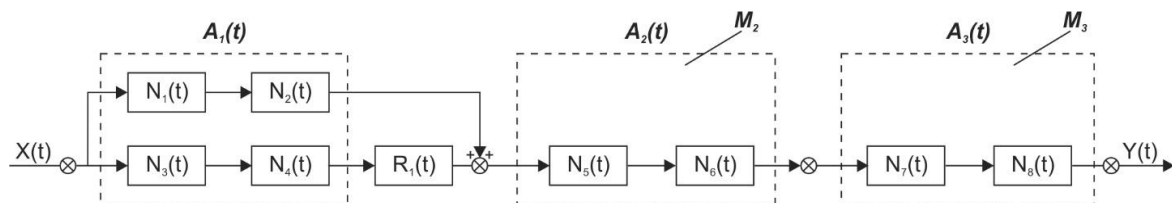

Fig.4. Model block reliability diagram for analyzed components of thermal power plant TE Kostolac

Where is:

M_1 - measuring location of the oscillation level on the shaft of the turbine,

M_2 - measurement location of temperature measurement on bearings,

M_3 - measuring location for measuring the weariness of the bearing.

Measuring location 1, includes components (N_1 i N_2), is a static component so it is $\omega_{N_1} = \omega_{N_2} = \omega_{R_1} \neq \omega_2$; so the relevant speed that affects the oscillation level $\omega_{N_1}(t) = f(N_1(t)_{N_1})$ it takes an input speed that equals the speed of the shaft $\omega_{N_1} = 600$ o(min), $\omega_{N_1} = \omega_{N_2}$.

Measurement results

The first part of the component N_1, N_2 i R_1 is:

$$\begin{aligned}
 M_{N_1} &= \frac{[N_1(t) \cdot N_2(t)] + [N_3(t) \cdot N_4(t)A_1(t)_{N_1}]}{\omega_{N_1} = \omega_{N_3} = f(\omega_1)} t_1 = \frac{[(P_{B_1} \cdot P_{B_2}) - R]}{\omega_1} t \\
 M_{N_2} &= \frac{N_5(t)N_6(t)A_2(t)_{N_2}}{\omega_{N_5} = f(\omega_2)} t_2 = \frac{P_{N_1}(t)}{\omega_2} t \\
 M_{N_3} &= \frac{N_7(t) \cdot N_8(t)A_3(t)_{N_1}}{\omega_{N_1} = f(\omega_1)} t = \frac{P_{N_7}(t)}{\omega_1} t \\
 M_{N_R} &= \frac{N_{R_1}(t) \cdot A_1(t)_{N_1}}{\omega_{N_1} = f(\omega_1)} t = \frac{P_{R_1}(t)}{\omega_1} t
 \end{aligned}
 \tag{11}$$

where is:

$J_{N_1}(t)$ - reliability of the workpiece during the useful working period,

$A_1(t)$ - amplitude oscillation of the impeller at the measuring point 1,
 ω_{N_1} - the angular circular velocity of the assembly at the measuring point 1 is in function
 $A_1(t)_{N_1}, A_1(t)_{N_2}, A_1(t)_{N_3}, A_1(t)_{N_4}, A_1(t)_{R_1}$
 t_1 - the time of the proper operation of the component,
 $(Q - J)_{A_1}(t)$ - polynomial with real coefficients that gives dependence of the reliability of the component's operation in the function of the value of the level of mechanical oscillations at the measuring point 1.
 Determination of partial reliability blocks:

$$A_1(t) = N_1(t) \cdot N_2(t) \cdot N_3(t) \cdot N_4(t) \quad (12)$$

$$O_i(t) = (N_1(t) \cdot N_2(t) \cdot N_3(t) \cdot N_4(t) + R_1(t)) \quad (13)$$

The first submodule includes components: alarm clock N_1 , bell N_2 , watering appliance R_1 , the transformation of the structure of the block diagram looks as follows (Figure 5)

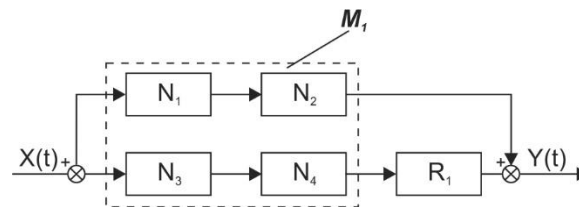

Fig. 5. Display of components for vibration monitoring

This analysis started from the method of determining the submodel according to the selected measuring points for determining the level of mechanical vibrations, and then the structure of the block diagram of the submodule connection was executed in the manner of the turbogenerator shaft movement.

In order to perform the general form of the transfer function of the optimal model, it is necessary to determine the expressions from the submodel N_i which are included in the locations of the measuring points of the vibration levels S_1 i S_2 (turbocharging pump and turbine pump):

$$O_1 = M_{N_1} M_{N_2} M_{N_3} + M_{R_1} = \left[\frac{J_{N_1}(t) A_1(t)_{N_1}}{\omega_{N_1}(t)} t \frac{J_{N_2}(t) A_1(t)_{N_2}}{\omega_{N_2}(t)} t \frac{J_{N_3}(t) A_1(t)_{N_3}}{\omega_{N_3}(t)} t \frac{J_{N_4}(t) A_1(t)_{N_4}}{\omega_{N_4}(t)} t \frac{J_{R_1}(t) A_1(t)_{R_1}}{\omega_{N_5}} t \right] \quad (14)$$

The expression for the resulting sub-module 1 is the sum:

$$O_1 = M_1 \cdot M_2 M_3 + M_R \quad (15)$$

The equations of the first-order model with real coefficients give dependence of the reliability of the components of the alarm clock in function is the value of the level of vibrations at the measuring points:

$$M_1 = \frac{[(P_{B_1} \cdot P_{B_2}) - R]}{\omega_1} \cdot t = \frac{(Q - J)_1(t)}{\omega_1} \cdot t \quad (16)$$

$$M_2 = \frac{(Q - J)_2(t)}{\omega_2} t \quad (17)$$

$$M_3 = \frac{(Q - J)_7(t)}{\omega_1} t \quad (18)$$

$$M_{R_1} = \frac{(Q - J)_1(t)}{\omega_1} t \quad (19)$$

The expression for the resulting sub-module 1 is the sum:

$$O_1 = \left(\frac{(Q - J)_{N_1}(t)}{\omega_1} \cdot \frac{(Q - J)_{N_2}(t)}{\omega_2} \cdot \frac{(Q - J)_{N_7}(t)}{\omega_1} \cdot \frac{(Q - J)_{R_1}(t)}{\omega_1} \right) \quad (20)$$

where is:

ω_i - number of shaft rotations,

$(Q - J)_i(t)$ - polynomial with real coefficients that gives dependence of the reliability of the component components at the measuring point 1.

Within the given measurements and the analysis of the monitoring of the changes in the parameters of the state of the oscillation amplitude values over time, the existing state in relation to the state by the introduction of new parameters will observe the value of the components work in relation to the previous state of operation.

CONCLUSION

Conducted research results will offer practical implementation and justification of programming such algorithm needed for understanding of mathematical models of optimization for vibro-diagnostic procedures that will give an analysis of condition and will represent dynamic circuits of turbo-generator, whose condition will be any moment with the value of input and output parameters [7, 8]. The model shall define a connection between periodicity of parameters check and signaling tolerance of parameters for components when securing desired level of reliability. Obtained values of research results will represent scientific and practical application of justification that is of special significance for improvement of vibro-diagnostic procedures and preventive maintenance procedures.

Based on the monitoring of such work ability of turbo-generator components, i.e. the functioning while considering within this analysis the methods and parameters by created algorithm, these values can be related within the model of the exploitation work.

REFERENCES

- [1] Barlow, R., *Mathematical Theory of Reliability*, New York, 1995.
- [2] Lu, W., Zhang, Y., Zhang, Y., Zhu, F., Research on the optimum equivalent availability factor of a large scale turbo generator, *Dianli Xitong Zidonghua/Automation of Electric Power Systems*, Vol.26, No.7., pp. 18-22, 2002.
- [3] Zhang, J., Li, R.-X., Han, P., Wang, D.-F., Yin, X.-C., Wavelet packet feature extraction for vibration monitoring and fault diagnosis of turbo-generator, *International Conference on Machine Learning and Cybernetics 1*, pp. 76-81. 2003.
- [4] Bloch-Mercier, S., A preventive maintenance policy with sequential checking procedure for a Markov deteriorating system *European Journal of Operational Research* Vol.142, No.3., pp. 548-576, 2002.
- [5] El-Damcese, M.A.Suggested procedure for preventive maintenance policy, *Microelectronics Reliability*, Vol.37, No.8., pp. 1173-1177, 1997.
- [6] Peng, H., Zhang, Y., Zhang, Y.-K., Zhang, Y., Zhu, F., Research on the optimized planned-maintenance period of turbo-generator, *Zhongguo Dianji Gongcheng Xuebao/Proceedings of the Chinese Society of Electrical Engineering*, Vol. 23, No. 7., pp. 41-4, 2003.
- [7] Vulovic, M., Prvulovic, S., Vulovic, S., Control model of turbo-machine vibrations with the help of Bode and Nyquist plots, *Comptes Rendus de L'Academie Bulgare des Sciences*, Vol.71, No.11., pp. 1528-1533, 2018.

- [8] Kazakoff, A.B., Tsveov, M.S., Double shock vibration isolator dynamic modelling subjected to extreme loading, *Comptes Rendus de L'Academie Bulgare des Sciences* Vol.67, No.12., pp. 1683-1690, 2014.

THE STUDY OF FACTORS AFFECTING THE QUALIFICATION OF PHARMACEUTICAL FACILITIES

Ilija Tabašević¹, Dragan D. Milanović²

¹Hemofarm, Vrsac, Serbia

²University of Belgrade, Faculty of Mechanical Engineering, Belgrade, Serbia

e-mail: ilija.tabasevic@hotmail.com

Abstract: Commissioning and qualification of pharmaceutical facilities are indispensable aspects of quality control in the pharmaceutical industry. It is of utmost importance for a facility to be adequately commissioned, as this is a prerequisite for the manufacturing of a quality product. Standards and regulations in the pharmaceutical industry have a limited amount of theoretical and empirical information on the qualification of facilities, which are partially based on systematic research processes. This paper identifies and explains factors that could have an effect on the success of qualification activities of pharmaceutical facilities, which in turn ensure the identification of priorities in all functional phases of the qualification process, as well as the interaction between contractors and people working in the pharmaceutical industry. The results obtained in this research will contribute to the field of qualification control in the pharmaceutical industry.

Key words: Qualification, Commissioning, Pharmaceutical industry.

INTRODUCTION

One of the basic requirements for drug production is the pharmaceutical quality system, which includes the application of GMP (Good Manufacturing Practice) in all phases of the drug life cycle. Commissioning and qualification of pharmaceutical facilities are essential to ensuring regulations and confirming that the drugs manufactured in them are suitable for their intended use.

GMP Annex 15 (2015) describes the qualification principles that apply to the premises, equipment, auxiliary systems and processes used for drug manufacturing. Any planned changes to the systems, which may affect product quality, must be formally documented, and the impact on qualification principles or the assessment control strategy must be assessed. The FDA suggests phases that need to be completed in order for a pharmaceutical facility to be commissioned (Figure 1).



Fig. 1. Design of a Facility and qualification [10]

These phases are not clearly defined, and cannot always be applied, which is why a model must be developed, which can lead to cost and time reduction, as well as efforts related to facility qualification. Moreover, this model should also insure an increase in the value of the qualification process on the whole. Commissioning can be defined as planning, coordination, management and execution of activities which constitute a bridge between the construction phase and the phase of operation and maintenance of the life cycle of the facility.

It is important to note that while commissioning can be applied to any system, qualification represents an aspect of commissioning of a facility, which will operate in accordance with GMP regulations. Upon design completion, construction and general commissioning, pharmaceutical facilities must be qualified and their processes validated. Qualification represents generation of documented evidence stating that processes are capable of consistently producing a finished product which meets quality specifications. When commissioning is properly applied, qualification can focus on what is really important – aspects which can affect the quality of the product. Commissioning never replaces system qualifications with a direct impact on the quality of the product. There are tendencies for overqualification, due to the lack of confidence in the performed installation (in fact, due to the lack of adequate commissioning). This not only increases the initial costs, but also unnecessary maintenance of the life cycle of the qualified condition [1].

LITERATURE REVIEW

GMP, as an umbrella document in the pharmaceutical industry mainly focuses on critical aspects in terms of compliance, finished product quality, quality control process, recovery, and process validation and cleaning procedures. However, these GMP criteria do not cover in detail the aspects regarding the issues related to the qualification of the facility. Commissioning is a systematic approach to launching a pharmaceutical facility to end users, and ensuring that critical design requirements and specifications are met [3]. Activities at this stage can include design reviews, factory testing, installation verification, and functional testing. Summary reports are generated upon commissioning and include results overview along with all the deviations which occurred during the testing.

According to [6], qualification of pharmaceutical facilities plays a major role, regardless of whether it does or does not have contact with the product, because an adequate facility is a prerequisite for obtaining a quality product. In their paper, the authors give a brief overview of qualifications of pharmaceutical facilities, along with qualification planning, qualification, methodology, change control and requalification plan. In [7] present research results which were obtained in numerous case studies of pharmaceutical facilities construction, and used for testing and gathering information on the best practical model of pharmaceutical plant qualification. The aim of the study was to investigate the method and manner in which validation activities are represented in the process of pharmaceutical facility construction, as well as to compare the obtained results with what needs to be done to get to a model of best practice. During the course of the research, it became clear that it is likely for construction project managers to have a tendency to look at quality as a production measure, while pharmaceutical project managers see it as safety and regulatory compliance. This difference in understanding and importance of qualification activities is neglected, or at best underestimated [7].

The risk management approach should be applied throughout the drug life cycle, especially in decisions about the scope and degree of qualification of system commissioning. Principles from ICH Q8, Q9, Q10 and Q11 [4] or other systems that guarantee at least the same level of product quality and safety should be used as support to qualification activities. The basic concepts of computerized and KGH systems are defined in [10]. Additionally, process phases and potential risks are identified, and risk mitigation actions are proposed. This shows how the scope of testing at commissioning can be estimated. Paper [5] presents risk management in the qualification of HVAC systems. It is essential to get detailed estimate of the scope of testing in order to reduce operating costs and investments, and to ensure the quality of products and facilities in accordance with GMP standards, but also in line with related standards and regulatory requirements. From a regulatory perspective, qualification is the responsibility of the end user, hence the facility owner must pay attention when delegating tasks to the contractors. In the beginning, the responsible person is the person in charge of commissioning. However, when the facility is "handed over" to a pharmaceutical company, the pharmaceutical company becomes responsible, as this represents a regulated pharmaceutical operation. The pharmaceutical company does not have to repeat all the steps of commissioning, but it must satisfy the regulatory authorities and provide documented evidence that the qualification was done in accordance with GMP. Most pharmaceutical companies emphasize the formal fulfillment of requirements, which leads to the conclusion that they rely heavily on standards and regulations, without knowing much about them. By searching and mapping the available literature, it can be concluded that there are certain inconsistencies when it comes to defining the terminology that accompanies the concept of project management in the pharmaceutical

industry. Research of this type contributes to a better understanding of the qualification process and provides additional certainty for an effective and robust process of system changes in the pharmaceutical industry.

RESEARCH METHODOLOGY

According to the recommendations laid out in [8], the research method consisted of the following phases:

1) The Analysis of former theoretical and empirical studies

Standards and regulations in the pharmaceutical industry have a limited amount of theoretical and empirical information on facility qualifications, which are not grounded in systematic research processes. There appear to be minimal or insufficient studies which examine the qualification process, together with the factors that affect internal control and at the same time the outcome of regulatory compliance. As a result, project team members have a limited understanding and misinterpretation of pharmaceutical facility qualification requirements.

2) Experiment set-up and questionnaire construction

In this research, a case study was conducted in order to approach a relatively insufficiently studied and undefined problem. The aim of the study was to use the acquired knowledge to develop a research plan, as well as to specify an already existing work. The research process started from direct experience, after which empirical regularities were discovered. The conceptual framework arose from the very course of research in the form of assumptions. The case study included over 30 reconstruction projects in pharmaceutical plants, as well as one huge project for the construction of the entire facility. The case study will not be the subject of this paper. Instead, it is used exclusively in the preliminary phases of the research, as it enables the generation of hypotheses that can be systematically tested with the help of a large number of cases. Based on the aforementioned case study, the idea of surveying employees who participate in the qualifications of facilities in the pharmaceutical industry arose.

The survey was adopted from Nail Render's doctoral dissertation entitled "The validation of the pharmaceutical buildings". After having conducted two case studies, interviewing and surveying, Render proposed a new cybernetic model of pharmaceutical facility qualifications. The conducted survey can be considered as a pilot survey, based on which shortcomings and flaws will be identified, in order for a new, modified survey to be created, which will be distributed to pharmaceutical companies, subsidiaries and contractors when appropriate conditions are created.

The instrument consisted of 63 questions on the topic of facility qualification. The questions included in the survey had the Likert scale. The Likert scale is the most commonly used scale today and uses a range of 5 to 9 levels. A five-level scale was used in this research. The middle of the scale indicated a neutral response.

As inexperience of the informants can affect the reliability of the collected data, the survey also included a question regarding the informants' experience (number of years), as well as the position in the company in which they currently work. The survey was designed so that:

- Every informant was first contacted either face to face, or via telephone, after which they were handed in the survey;
- The survey contained contact information;
- The survey was anonymous;
- The questions were grouped according to conceptual units

3) Method of survey distribution

According to [9], the most commonly used methods of distributing questionnaires are personal delivery (in paper form), delivery by e-mail, or via the web. The best, but also the most expensive method of data distribution is personal distribution of questionnaires in paper form. In this study, the research instrument was delivered in person to 23 informants and by e-mail to 29 informants. The web method was not employed, so in addition to the volume of the questionnaire itself, the length of the time period for providing data, as well as manual sorting of the results can be considered as possible flaws of the instrument. The survey was distributed exclusively to employees who had prior knowledge and experience in facility qualifications and system commissioning. After the distribution of the research instrument, the time required for the returning of the filled-in questionnaire was 30 days.

4) The quantity and characteristics of the sample

45 informants responded to the survey. Out of 45 informants, 14 did not finish the survey completely. These informants were contacted and they subsequently finished the missing questions, so that no questionnaire was rejected. The response to the delivery of 23 research instruments in person was 20 respondents (or 87%), while the response was slightly lower in the case of electronic delivery, 25 out of 29 sent (or 86%). A given sample size of 45 informants is considered to be adequate in describing a population.

The structure of the informants with respect to education level is as follows: 4% PhD, 80% MA degree, and 16% secondary education. Activity-wise, 16% of the informants are employed in companies that perform contract work on pharmaceutical facilities, while 84% of the informants work in the pharmaceutical sector.

RESULTS AND DISCUSSION

The instrument consisted of 54 questions about object qualifications, Likert five-level scale was used, with the following possible answers: SA - Strongly agree; A - Agree; N - Neither agree or disagree; D - Disagree; SD - Strongly disagree. The questions were grouped by the most critical categories, according to Table 1. The researcher directly participated in the qualification processes of over 30 pharmaceutical reconstruction projects. Based on the aforementioned experience, the most critical questions from each category were selected.

The number in brackets shows the number of questions that have been analyzed in detail, and the results of which will be presented in the remainder of this paper, for each category respectively.

Table 1. Question categorization

Category	Number of questions
Timing	3 (1)
Partnering	1 (1)
Implementation	5 (1)
Cost	12 (1)
Quality	30 (3)
Culture	3 (1)

Timing

Based on the results of the survey item in question, it is clear that opinions are divided. This question created considerable dilemma: out of 14 incomplete questionnaires, 9 did not have this particular question answered. It was unclear to the respondents whether the persons in charge of qualification were employed in the QA (Quality Assurance) sector. The starting document for changes to the system is the URS (User Requirements Specifications), which is approved by QA, and participates in the project from the very beginning. The URS should be written as correctly and precisely as possible - it is a key

document which very often represents the basis of the contract - a definite statement about what the system must perform. In order for the survey question under discussion to be utilized, it requires reformulation in such a way that the essence of the question becomes that qualification teams and QA teams participate in the project from the very beginning.

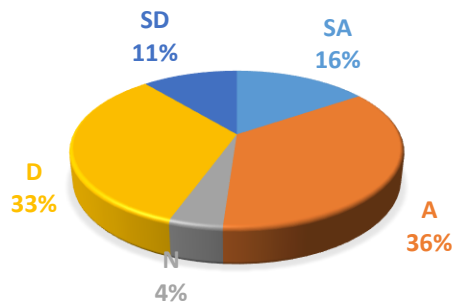

Fig. 2. Timing – Question 1 (The design / construction team are rarely involved with the clients QA team early in the project)

Partnering

The informants are aware of the importance of cooperation and communication in the project. It is very important to put together a qualification team which will monitor all developments in cooperation with the contractor, production managers and QA representatives. This should be done at an early stage of the project. Project progress meetings are mandatory, but one of the disadvantages of these meetings is that they are time-consuming, as they are attended by too many different disciplines.

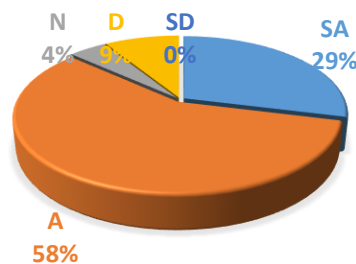

Fig. 3. Partnering – Question 1 (Projects run more smoothly when an integrated/partnering approach is adopted, i.e. all those involved with any aspect of the project have an input into the project, including validation at an early stage)

Implementation

There seems to be minimal or insufficient research which examines the qualification process of pharmaceutical facilities, as well as the factors that affect internal control and in turn the outcome of regulatory compliance. Consequently, the levels that need to be achieved are not clear to the contractors, and they see qualification as a financial risk, since they have to hire specialists in the field. Contractors can be in charge of commissioning activities, but qualification is a regulated pharmaceutical operation, so the responsibility lies with the pharmaceutical company.

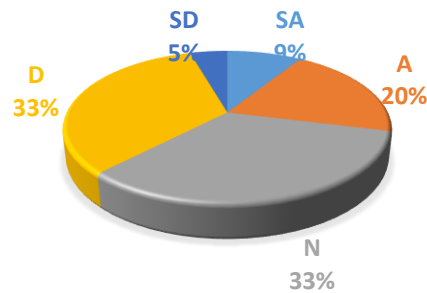

Fig. 4. Implementation – Question 1 (Validation is generally better left to the organizations who design/install as they have a more detailed understanding of the systems)

Cost

The costs of commissioning and facility qualification are mainly determined by its design, so these costs should be included in the development of the optimal design solution. Planning matrix is an indispensable part of each project, as it identifies all qualification activities from which the costs arise, which can be seen from the answers in Figure 5.

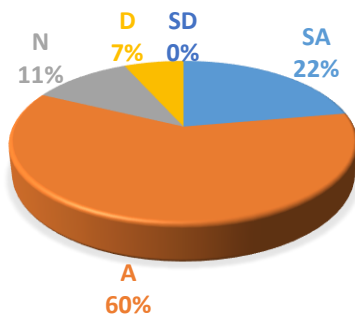

Fig. 5. Cost – Question 1 (The calculation of facility validation cost is based on: Use of a planning matrix where all possible validation activities are identified)

Quality

The first thing which a pharmaceutical company must do when it comes to the management of qualification activities is to get acquainted with the requirements of various regulatory bodies, and to get a good understanding of them. The Quality - Question 1 showed that informants are aware of the fact that it is of utmost importance to respect regulations and standards. Nevertheless, Question 3 shows that they do not know much about them. Question 3 is an indicator of the informants' ignorance of regulations and standards, as commissioning never replaces system qualifications with a direct impact. In the entire research instrument, Quality - Question 2 has the highest congruence. Regulatory bodies (inspections) follow the instructions from the standards and regulations. Hence, by respecting the valid regulations, standards and guidelines in the field of qualifications of pharmaceutical facilities, the expectations required by the regulatory bodies are justified. The existence of a complete documentation following all phases is almost equally important. As one FDA reviewer put it: "If it is not documented, it is a rumor."

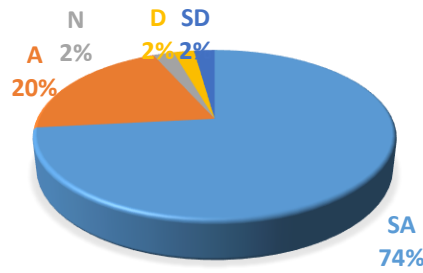

Fig. 6. Quality – Question 1 (The validation of a pharmaceutical facility is: An essential requirement for regulatory compliance)

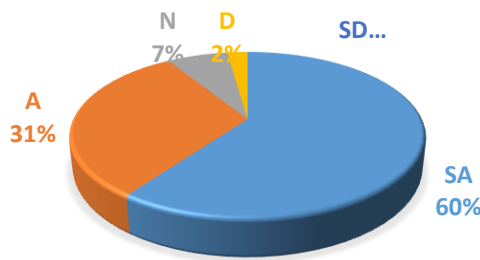

Fig. 7. Quality – Question 2 (A validated facility is considered compliant when it: Satisfies regulatory inspection)

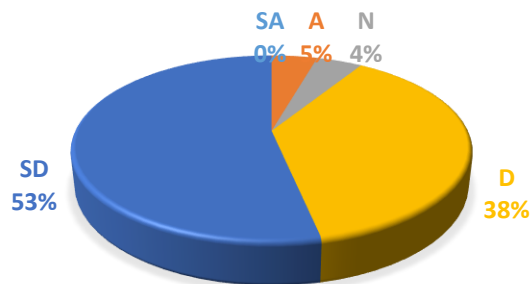

Fig. 8. Quality – Question 3 (Project validation should not be necessary if high quality commissioning is carried out)

Culture

Contractors are mainly construction companies that are not trained according to the guidelines and regulations that apply to the pharmaceutical industry. Because of this lack of proper training, it is crucial to establish a common language that allows for a clear communication between all interested parties in the effort of achieving a successful qualification. From a regulatory perspective, qualification is the responsibility of the end user, so the pharmaceutical company must be careful when delegating tasks to the contractor, because in most cases a lot is expected.

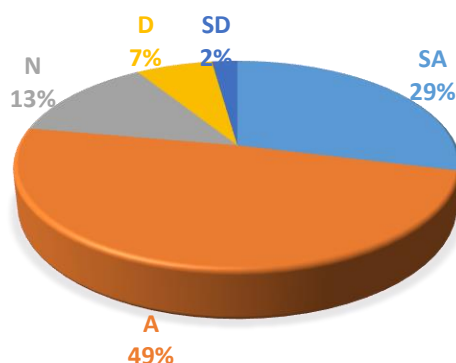

Fig. 9. Culture – Question 1 (Most construction companies are not sufficiently experienced to complete the validation of a facility i.e. writing protocols, carrying out tests and reporting outcomes)

CONCLUSION

The quality and safety of the finished product are of crucial importance in the pharmaceutical industry. An adequately commissioned facility is one of the prerequisites for obtaining a quality production process. Criteria according to which the success of a project can be assessed can be defined through time, price and quality. Price and time can be easily measured. The meaning of quality, on the other hand, is a very demanding concept, and this is where the problem of successful qualification lies. The framework of facility qualification presented in this paper was developed through a research instrument - a survey which identified different views on the meaning of quality. This research shows the possibility of defining the factors that affect the qualification of pharmaceutical facilities. Further research in this direction can bring about a modified survey that can be distributed to pharmaceutical companies, subsidiaries and contractors. The results of such survey can lead to a new cybernetic model for the qualification of pharmaceutical facilities.

REFERENCES

- [1] Blackburn, T. D. Commissioning Fundamentals and a Practical Approach, 2012.
- [2] European Commission, "Good Manufacturing Practice Medicinal Products for Human and Veterinary Use" Annex 15, Qualification and Validation, Brussels, 2015.
- [3] ISPE Pharmaceutical Engineering, "Baseline Guide: Commissioning & Qualification 2nd Edition", 2017.
- [4] ISPE Pharmaceutical Engineering, "Positioning Paper: Use of Building Management Systems and Environmental Monitoring Systems in Regulated Environments", 2005.
- [5] Kamakshi, Sharma, R.B., Risk Management of HVAC System in Pharma Industries, International Journal for Pharmaceutical Research Scholars (*IJPRS*), 4(3), 50-56, 2015.
- [6] Kashid, V. A., Nikam, V. K., Somwanshi, S. B., Dolas, R. T., Dhamak, K. B., Gaware, V. M., & Kotade, K. B., Brief Overview of Pharmaceutical Facility Validation. Journal of Current Pharma Research, 4(2), 1134, 2014.
- [7] Render, N., The validation of pharmaceutical buildings (Doctoral dissertation, Northumbria University), 2006.
- [8] Spasojević Brkić V., Milanović D.D., Knežević S., Lazić D., Milanović T.: Sistem menadžmenta kvalitetom i poslovne performanse, Mašinski fakultet Univerziteta u Beogradu, 2012.
- [9] Spasojević Brkić V.: Kontigentna teorija i menadžment kvalitetom, Mašinski fakultet Univerziteta u Beogradu., 2009.
- [10] Tabašević I., Milanović D.D., Quality management for computerized pharmaceutical systems. International Conference Industrial Engineering end Environmental Protection, Zrenjanin, Serbia, 2019.
- [11] US Food and Drug Administration., Guidance for industry: Q9 Quality risk management. Bethesda, MD, 2006.

ON PID CONTROLLER DESIGN FOR A HIGH-ORDER SYSTEMS

Saša Lj. Prodanović¹, Ljubiša M. Dubonjić²

¹University of East Sarajevo, Faculty of Mechanical Engineering,
East Sarajevo, Bosnia and Herzegovina

² University of Kragujevac, Faculty of Mechanical and Civil Engineering in
Kraljevo, Kraljevo, Serbia

e-mail: sasa.prodanovic@ues.rs.ba , sasa.prodanovic77@gmail.com
dubonjic.lj@mfkv.kg.ac.rs

Abstract: Investigation of PID (proportional-integral-derivative) controller and its shorter variants (PI and P) for high-order systems has been carried out and presented in this paper. Famous Ziegler-Nichols method based on frequency response was used without previous model reduction of system. Tuning procedure and system functioning were performed by means simulations. According specificity in the obtained results, caused by system particularities, some corrections in the PID parameters tuning rules have been suggested. Applicability of proposed procedure has been proved on the several high-order systems.

Key words: PID control, high-order systems, non-reduced models

INTRODUCTION

Appropriate mathematical model of system is very important precondition for its successful control. It is usually necessary to make a compromise between order of mathematical model and amount of information that are enough for representation of system dynamic behavior. High-order model of system can be obtained both using various identification procedures and by means physical laws. These high-order models make troubles, because computational methods for tuning of PID controller have been usually derived up to second-order models. Many approaches tend to overcome this obstacle. In this regard, Desai and Prasad [1] developed method for model reduction of linear system. This method is consisted of big bang big crunch optimization technique and stability equation method for numerator and denominator terms of reduced system, respectively. Isaksson and Graebe [2] researched the other one approach to model reduction intended for PID design. Safonov and Chiang [3] tried to achieve robust control, where they used model reduction, too. Wide and comprehensive overview to model reduction problem, in order to make model of system easier for controller tuning, has been given by Obinata and Anderson [4]. A new model reduction method, dealing with fractional order plus time delay model, for PID controller design has been developed in [5]. Suitable new method for model reduction using genetic algorithm with accuracy checking in the Nyquist plane, as well as tuning rule for fractional PID controller, have been investigated and determined in the [6]. Beside aforementioned attempts to reduce the system to acceptable form for controller design, there are another set of approaches that contain tuning rules without changing system mathematical model. Fractional order PID controller enables more possibilities regarding fulfilling demands for system properties. So, it is fully comprehensible the presence of numerous attempts for its design. In this regard, one of them Shah and Agashe [7] developed fractional order PID controller for high order system based on optimal tuning in time-domain without model reduction.

This investigation has also aim to design PID controller without previous system model reduction. It has been carried out by using and afterward correcting Ziegler-Nichols method based on frequency response [8], which is clearly explained in [9].

Paper is consisted of five sections. This introduction is followed by section containing problem definition. Hydrostatic power transmitter as controlled object, PID controller design for it and its variation and suggested corrections of the expressions for controller terms calculations are involved in the section titled hydraulic system as example. Additional examples presented by high-order transfer functions with and without time-delay, have been considered in the next one section. After that, conclusions have been given.

PROBLEM DEFINITION

Ziegler - Nichols method based on frequency response is experimental approach and due to that various difficulties are possible during its performance [8,9]. First of all, there are difference between tuning and functioning phase of the system. Namely, experimental tuning of the PID controller is carried out according configuration in Fig. 1. It is highly suitable for design of PID controllers for high-order systems, because it enables avoiding model reduction.

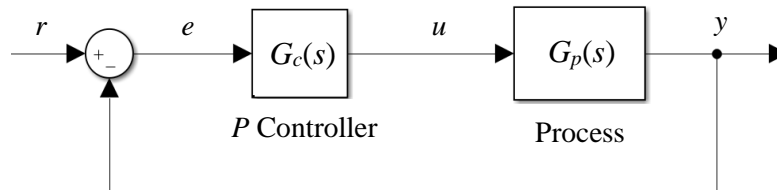

Fig. 1. Configuration for controller tuning according Ziegler - Nichols method [8,9]

The meaning of variables in the Fig. 1. are: r – reference value, e – error, u – manipulated value, y – controlled value (system response).

Controller is set to only proportional (P) term, by turning off its integral and derivative terms. Then P term is increasing until system response get into oscillating region. In that boundary stable state ultimate period T_u of oscillation should be determined. Ultimate gain K_u is known from value of P term, which caused response's oscillation. Using these two ultimate values and expressions in the Table 1, parameters of the PID controller (1) can be determined [8,9].

$$G_c(s) = K_p \left(1 + \frac{1}{T_i s} + T_d s \right) = K_p + \frac{K_i}{s} + K_d s \quad (1)$$

Where: $K_p \equiv P$ – proportional gain, $K_i \equiv I$ – integral gain, $K_d \equiv D$ – derivative gain, T_i – integral time constant and T_d – derivative time constant.

Table 1. Parameters of PID controller according Ziegler - Nichols method of frequency response [8,9]

Controller	K_p	T_i	T_d
P	$0,5 K_u$	-	-
PI	$0,4 K_u$	$0,8 T_u$	-
PID (parallel)	$0,4 K_u$	$0,5 T_u$	$0,125 T_u$
PID (serial)	$0,3 K_u$	$0,157 T_u$	$0,25 T_u$

According this method, in the tuning stage, feedback given in the configuration in Fig. 1, can contain only proportional term, in order to system can reach boundary stable state (oscillation in the response). Significant problem is appearing in the functioning stage of systems, which contain sensors (in the feedback) that are integral and/or derivative types. In that cases, corrections of expressions for PID controller design in Table 1 are required.

HYDRAULIC SYSTEM AS EXAMPLE

Hydraulic systems are good solutions for enabling high forces in the industry. Therefore, design of control systems for two similar electro-hydraulic systems will be considered in this section.

System description

Very representative example in the sense of above mentioned problem is hydrostatic power transmitter, which has been described as a high-order system without time delay and explained in detail in [10,11]. Its functional schema is given in the Fig. 2, where all components of this electro-hydraulic positioning servo system can be seen. This control system is consisted of two parts: power transferring part and control device for servo pump (SP). Obviously, this is controlling of angular position ϑ_m of the hydro motor (HM) by changing of volumetric flow rate of servo pump (SP). Flow rate of servo pump (SP) depends on position of the tilting plate, which is driven by linear hydraulic motor (LHM) that is controlled by electro-hydraulic directional servo valve (EHDSV). Reference value is determined by setting input voltage U_u .

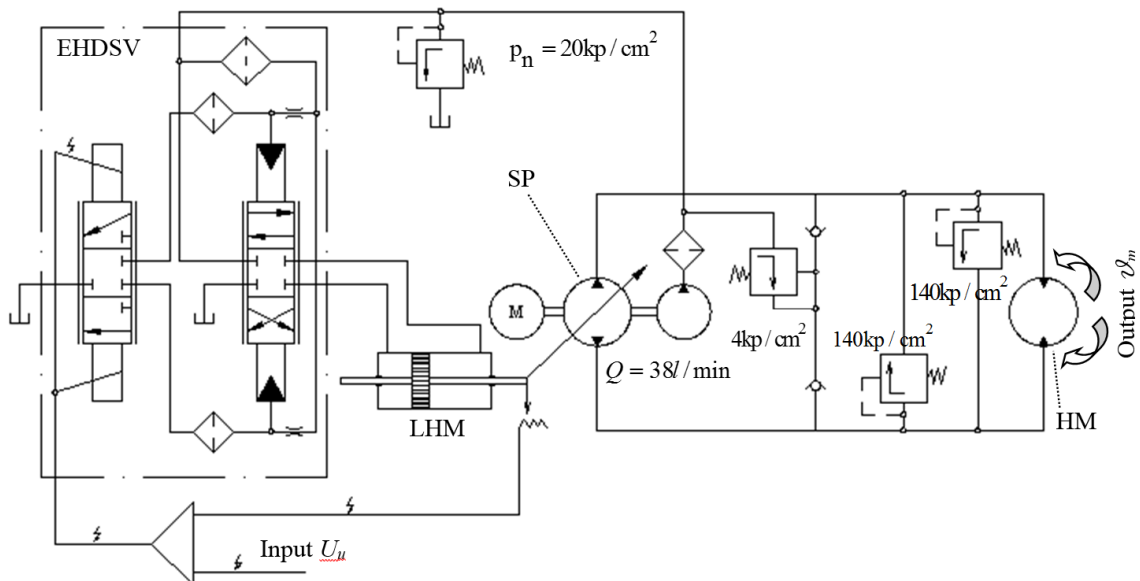

Fig. 2. Shema of the electro-hydraulic positioning servo system [10,11]

Open loop transfer function of considered servo system (Fig. 2) is given by (2) [10] and its block diagram can be seen in Fig. 3 [10].

$$G_p(s) = \frac{0.29}{0.00003s^2 + 0.0198s + 1} \cdot \frac{0.0012s^2 + 0.007s + 1}{0.0006s^3 + 0.0025s^2 + s} \quad (2)$$

As it can be seen in (2), considered servo system is modelled as fifth-order system without time delay. This characteristic is not going along with basic Ziegler - Nichols method, because they developed expressions for calculation of PID controller parameters for systems with time delay.

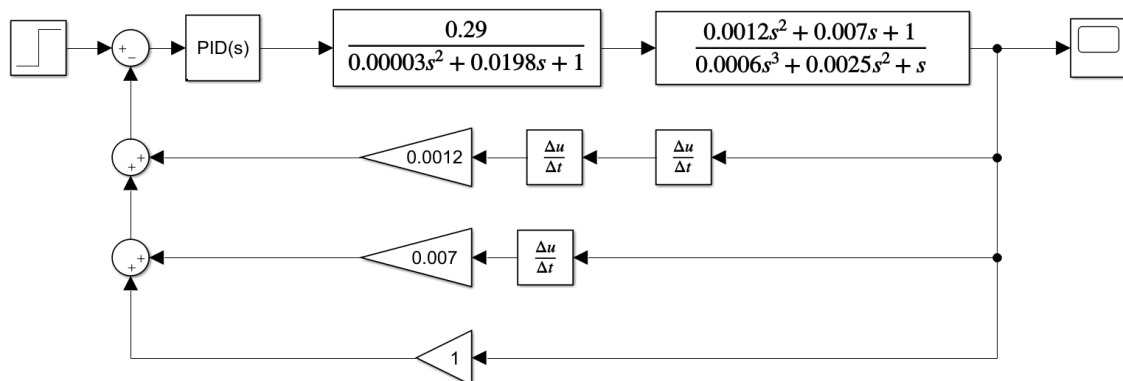

Fig. 3. Block diagram of the electro-hydraulic positioning servo system [10]

To obtain better system dynamic behavior, beside position sensor, velocity sensor (tachogenerator) and accelerometer (pressure sensor) have been introduced into control loop, as Fig. 3 shows.

Procedure for controller design

At first, based on Ziegler - Nichols frequency method, configuration in Fig. 1, with unit feedback, is used to make system response oscillate. Additional sensors, as in Fig. 3 have been avoided in this tuning stage, because they didn't lead to boundary stable state of the system. Gradually increasing of proportional gain P , according configuration in Fig. 1, gives oscillatory response (angular position ϑ_m) shown in Fig. 4. Reference value is set to be $r = 4$ rad.

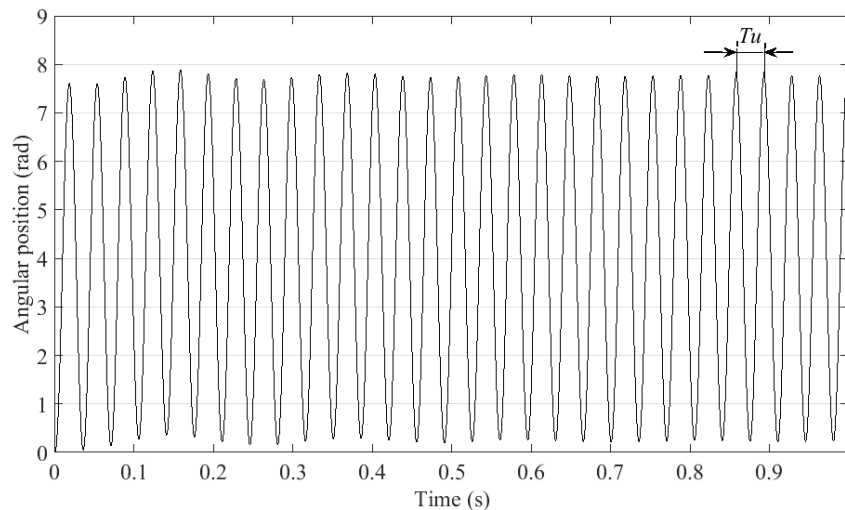

Fig. 4. Oscillatory response of the system (2)

Now, ultimate gain K_u and ultimate period T_u are known as $K_u=1072.6$ and $T_u= 0.035(s)$. Mentioned problems appears because introducing K_u and T_u into expressions in the Table 1 and calculating parameters of PID controller based on them, didn't give appropriate system response. This is caused with differences in the feedback in tuning and functioning stage of the system. After that, a lot of simulations (Fig. 3) of system functioning had been performed in order to determine corrected expressions for determining of PID controller terms and they are shown in Table 2. Corrections haven't been suggested for serial PID controller because it wasn't considered in this investigation, i.e. parallel PID controller has been used.

Table 2. Corrected expressions for PID controller according to Ziegler - Nichols method of frequency response

Controller	K_p	T_i	T_d
P	$K_u / (100 \div 150)$	-	-
PI	$K_u / 170$	$150 T_u$	-
PID (parallel)	$K_u / 170$	$150 T_u$	$0.125 T_u$
PID (serial)	$0.3 K_u$	$0.157 T_u$	$0.25 T_u$

According them, values of controller parameters are following:

$P=7.1507$

$P1=10.726$

$P=6.3094, I=1.2018$

$P=6.3094, I=1.2018, D=0.0276$

It is important to say that P controller was calculated using highest value in the suggested range $K_u/150$, while P1 controller has been calculated with lowest value in the mentioned range $K_u/100$. This range was adopted for response speed adjusting. Responses of the investigated electro-hydraulic

system (Fig. 5) were obtained by introducing obtained PID parameters into configuration shown in Fig. 3 and they are generally good. Obviously, response controlled by P1 controller is faster than response controlled by P controller. PI and PID controllers cause practically the same responses due to low value of the derivative term. Namely, this figure shows responses for characteristic tuned controllers, but P controller is the best one due to absence of overshoot and steady state error and short enough rise time.

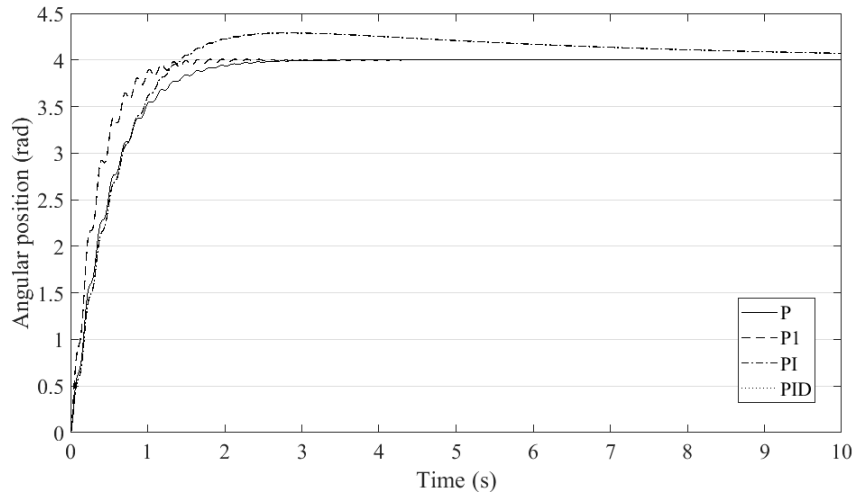

Fig. 5. Responses of the electro-hydraulic system (2)

Changed system

To prove validity of the corrected expressions for PID controller design, some changes have been introduced into mathematical model (2) of servo system (Fig. 2.) and presented by (3). Transfer function (3) has been changed by different coefficients of the numerator and denominator, but not structurally. Therefore, it can present different system.

$$G_p(s) = \frac{0.87}{0.000015s^2 + 0.0099s + 1} \cdot \frac{0.0036s^2 + 0.021s + 1}{0.0003s^3 + 0.0012s^2 + 0.5s} \quad (3)$$

By carrying out above explained Ziegler - Nichols method for system (3), ultimate gain K_u and ultimate period T_u are determined $K_u=60.793$ and $T_u= 0.025(s)$. Using again expressions in the Table 2. parameters of the controller has been calculated, as follows:

$$P=0.4053$$

$$P1=0.6079$$

$$P=0.3576, \quad I=0.0954$$

$$P=0.3576, \quad I=0.0954, \quad D=0.0011$$

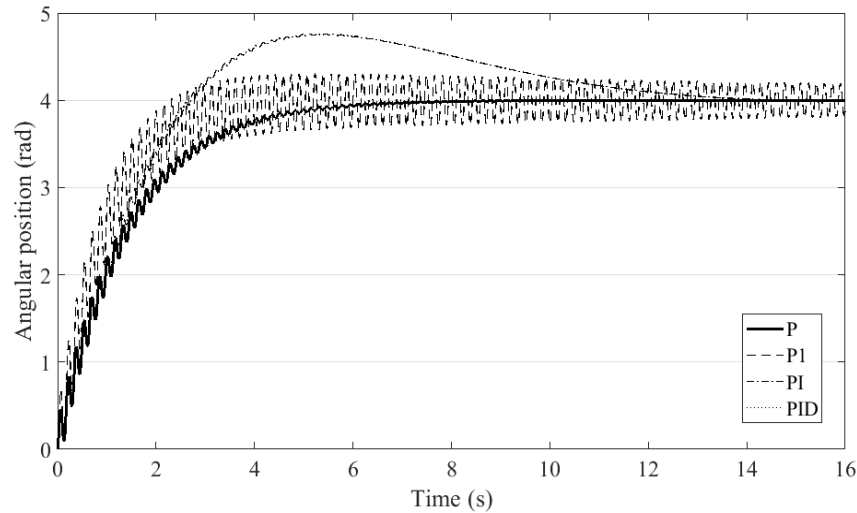

Fig. 6. Responses of the changed system (3)

The meanings of controller's marks are the same as for system (2) in the previous example. Simulations of system functioning were performed as in previous example. These controllers give responses in the Fig. 6. Responses in Fig. 6. put in the foreground P controller as the best solution for the system (3). The reasons are the same like in above example, i.e. absence of overshoot and steady state error and short enough rise time. Other types of controllers is not good enough due to oscillations or overshoot higher then 10%.

ADDITIONAL EXAMPLES

In this chapter, two additional examples will be considered in order to explore high-order systems without pole in the origin of complex plane. The first one is given by (4) [7].

$$G_p(s) = \frac{1}{s^4 + 4s^3 + 6s^2 + 4s + 1} \quad (4)$$

In addition to that transfer function (4) don't have pole in the origin of complex plane, this system is without time delay. So, there are two differences regarding basic Ziegler - Nichols method. Method that extend Ziegler - Nichols, called Tyreus - Luyben method, has been used for calculation of PID controller parameters for system (4) due to enabling better system responses. Expressions for parameter calculation is tabulated in Table 3.

Table 3. Parameters of PID controller according to Tyreus - Luyben method [9]

Controller	K_p	T_i	T_d
P	-	-	-
PI	$K_u/3.2$	$2.2 T_u$	-
PID	$K_u/2.2$	$2.2 T_u$	$T_u/6.3$

Differences in the defined preconditions for this method usage cause corrections of its expressions too. These corrections have been suggested based on results obtained from simulations of system functioning. Mentioned expressions is given in Table 4. It is important to say that corrections of expressions were made only for proportional term, i.e. integral and derivative term are determined using unchanged expressions in Table 3.

Table 4. Corrected expressions for PID controller according Tyreus - Luyben method

Controller	K_p	T_i	T_d
P	-	-	-
PI	$0.1 K_u$	$2.2 T_u$	-
PID	$0.1 K_u$	$2.2 T_u$	$T_u/6.3$

Tyreus - Luyben method (Table 3.)

PI P=1.25, I=0.0905
 PID P=1.8182, I=0.1316, D=1.8124

Tyreus - Luyben method, corrected (Table 4.)

PIcor P=0.4, I=0.0905
 PIDcor P=0.4, I=0.1316, D=1.8124

System responses in the Fig. 7. are result of applying structure in Fig. 3. for system (4) with tuned controllers PI, PID, PIcor and PIDcor. Without any additional explanations, it is noticeable that controllers tuned using corrected expressions enable significantly better responses.

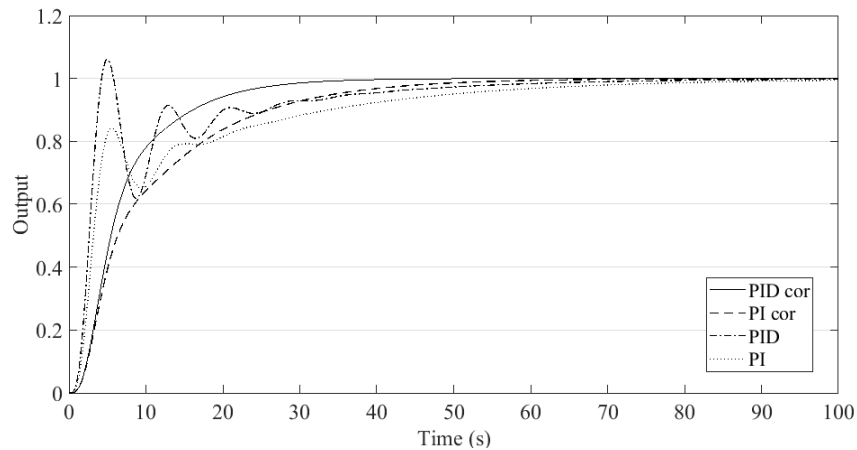

Fig. 7. Responses of the system (4)

One more high-order system (5) [7] is considered below, but with time delay.

$$G_p(s) = \frac{1}{s^5 + 2s^4 + 5s^3 + 7s^2 + 4s + 1} e^{-2s} \quad (5)$$

The same procedure as for system (4) has been carried out. Controller's parameters and simulated responses (Fig. 8.) follow.

Tyreus - Luyben method (Table 3.)

PI P=0.5084, I=0.0194
 PID P=0.7395, I=0.0282, D=1.3969

Tyreus - Luyben method, corrected (Table 4.)

PIcor P=0.1627, I=0.0194
 PIDcor P=0.1627, I=0.0282, D=1.3969

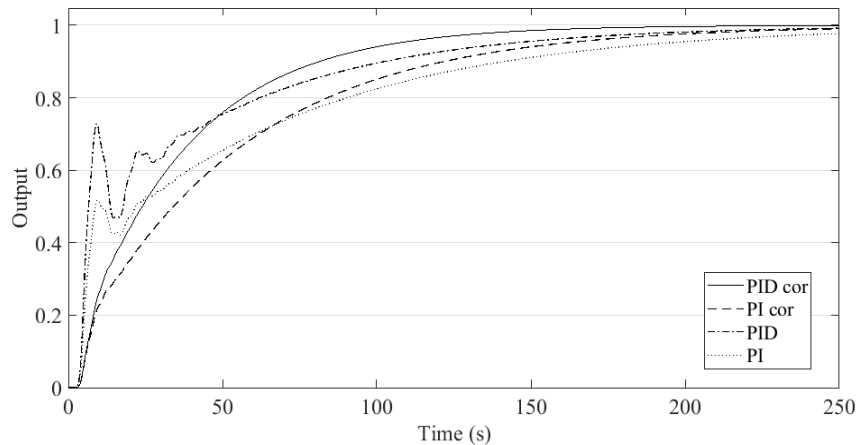

Fig. 8. Responses of the system (5)

From Fig. 8, is also evident that corrected expressions give controllers, which enables so much better responses. In this way applicability of suggested expressions for calculation of PID controller terms has been proved.

CONCLUSION

Suggested corrections of the Ziegler - Nichols method and its upgraded version (Tyreus - Luyben method) enable calculation of controller parameters for high-order systems without their model reduction. This approach enables avoidance data loss that can be important for reflection of system behavior. In this way, differences between tuning and functioning stage of the system have been overcome, because system closed loop can contain various types of sensors. Effectiveness of the determined expressions have been proven on the various examples: with and without pole in the origin of complex plane and with and without time delay. Obtained responses have good quality indicators. Moreover, ranges for the particular expressions for controller terms calculation have been determined in order to achieve influence to the response speed.

ACKNOWLEDGMENT

The authors wish to express their gratitude to the Serbian Ministry of Education, Science and Technological Development - MPNTR for the partly financing of this paper through the project whose contract number is: 451-03-68/2020-14/200108.

REFERENCES

- [1] Desai, S.R. and Prasad, R., A new approach to order reduction using stability equation and big bang big crunch optimization, *Systems Science & Control Engineering: An Open Access Journal*, Vol. 1, No. 1, pp. 20-27, 2013.
- [2] Isaksson, A.J., Graebe S.F., Analytical PID parameter expressions for higher order systems, *Automatica*, Vol. 35, pp. 1121-1130, 1999.
- [3] Safonov, M.G. and Chiang, R.Y., Model Reduction for Robust Control: A Schur Relative Error Method, *International Journal of Adaptive Control and Signal Processing*, Vol. 2, pp. 259-272, 1988.
- [4] Obinata, G., Anderson, B.D.O., *Model Reduction for Control System Design*, Springer-Verlag London, 2001.
- [5] Jin, C.Y., Ryu, K.H., Sung, S.W., Lee, J., Lee I-B., PID auto-tuning using new model reduction method and explicit PID tuning rule for a fractional order plus time delay model, *Journal of Process Control*, Vol. 24, pp. 113-128, 2014.

- [6] Das, S., Pan, I., Das, S., Gupta, A., Improved model reduction and tuning of fractional-order $PI\lambda D\mu$ controllers for analytical rule extraction with genetic programming, *ISA Transactions*, Vol. 51, pp. 237-261, 2012.
- [7] Shah, P., and Agashe, S., Design of Controller for a Higher Order System Without Using Model Reduction Methods, *Progr. Fract. Differ. Appl.* Vol. 3, No. 4, pp. 289-304, 2017.
- [8] Ziegler, J.G., Nichols, N.B., Optimum settings for automatic controllers, *Trans. ASME* Vol. 64, pp. 759-768, 1942.
- [9] Filipović, V.Ž., Nedić, N.N., *PID Controllers*, University of Kragujevac, Faculty of Mechanical Engineering, Kraljevo, 2008, (in Serbian).
- [10] Abduli, R., Ciner, P., "Analog and digital modeling of an automatic system with a hydrostatic transmission", *Technical Military Academy of the Armed Forces KoV*, Zagreb, 1976.
- [11] Prodanović, S., *Simulation of electro-hydraulic servo systems*, Seminary work, Faculty of Mechanical Engineering Kraljevo, University of Kragujevac, 2008, (in Serbian).

CBM CONCEPT-PREDICTIVE MAINTENANCE-VIBRATION ANALYSIS AND BALANCING PROCESS OF INDUSTRIAL FANS

**Borivoj Novaković¹, Ljiljana Radovanović¹, Rade Ivetić²,
Vladimir Šinik¹, Mića Đurđev¹, Luka Đorđević¹**

¹University of Novi Sad, Technical Faculty "Mihajlo Pupin", Zrenjanin, Serbia

²Ivetim, Zrenjanin, Serbia

e-mail: novakovicborivoj1812@gmail.com

Abstract: The predictive maintenance system is increasingly playing an important role in large production systems. Vibrodiagnostics has emerged as one of the main tools in such a way of thinking. Using of these diagnostic methods leads to a significant reduction of maintenance costs, because in that way expensive corrective measures are avoided. Predictive thinking leads to the prevention of the highest costs, in the form of production downtime due to unplanned machine failures. The popular "Conditional Monitoring" is a modern approach, where modern systems and software tools for monitoring the status of the system are used to maintain a particular system. Applying the right instruments tends to increase production efficiency in terms of reducing maintenance costs and sudden system shutdowns, which is actually one of the largest sources of production costs.

Key words: Vibrodiagnostics, predictive, maintenance, conditional, monitoring.

INTRODUCTION

Systems of modern generations, which means systems implemented in the 21st century require the reliability of the system at a very high level. Modern concepts of condition-based maintenance are basically based on condition monitoring, whose task is to identify the existence or development of failure on the basis of measurable symptoms. The essence of the predictive concept is reflected in the use of non-destructive techniques in order to determine potential failures very early, so that appropriate corrective actions or repairs are planned in time only when there is a real need for it. [1, 2]. All aspects of industrial systems, both in the branch of production, machine design, maintenance, tend towards a certain level of automation. According to the claim [3], with the expansion of digitalization and the advent of the Industry 4.0 concept, the aim is to optimize industrial production, with a fundamental approach to collecting important data. Predictive maintenance has been identified as a leading segment of the popular analytics industry. The ratio of the potential of the predictive way of maintenance and its actual application is at a very low level, great potentials and a small degree of utilization of this type of technology is one of the brakes on the development of industrial analytics. The records that are monitored represent a complex amount of data, however research shows that sometimes this data is of no use to organizations that have implemented this type of maintenance. If such occurrences are frequent, i.e. in order to improve risk assessment, it is necessary to introduce new methods for risk assessment [4]. To the implementation of CBM implemented a quality [5] believe that it is necessary to have modern devices that correspond to the system being controlled, and to be adequately integrated into the maintenance program.

PREDICTIVE MAINTENANCE IN CBM PHYLOSOPHY

Basics of the CBM concept and predictive maintenance

CBM concept is composed of three key steps toward [6, 7] and those are:

- Collecting relevant data to create a successful system,
- Data processing (management of obtained information), signal processing important for understanding the problems of the system,
- Making a decision on the method of maintenance based on the collected data, proposing an effective maintenance policy.

Diagnosis as an aspect of maintenance according to the condition, deals with the detection, isolation and identification of the occurrence of the problem, before the occurrence. Detection indicates whether an error occurs during the monitoring of the system being monitored, while the isolation task is to locate the fault of the faulty system component. Figure 1 schematically shows the three basic steps in the CBM concept [7].

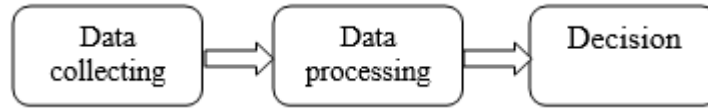

Fig. 1. Three basic steps in the CBM concept

In order for predictive maintenance, to which this concept belongs, to be carried out, the forecast of the future state of the system must integrate the maximum of available information in order to bring the conclusion about the state of a system as close as possible to the real state [8]. The main task of condition based maintenance is to detect a system failure at an early (initial) phase formation and take measures to prevent its occurrence [9, 10].

It can be concluded that the CBM maintenance concept must be approached thoroughly and in detail, and that the concept should focus on a few basic steps and modules, i.e. on diagnostics and decision support. The figure 2., shows a schematic representation of the necessary steps to be performed in order for the CBM module to be complete.

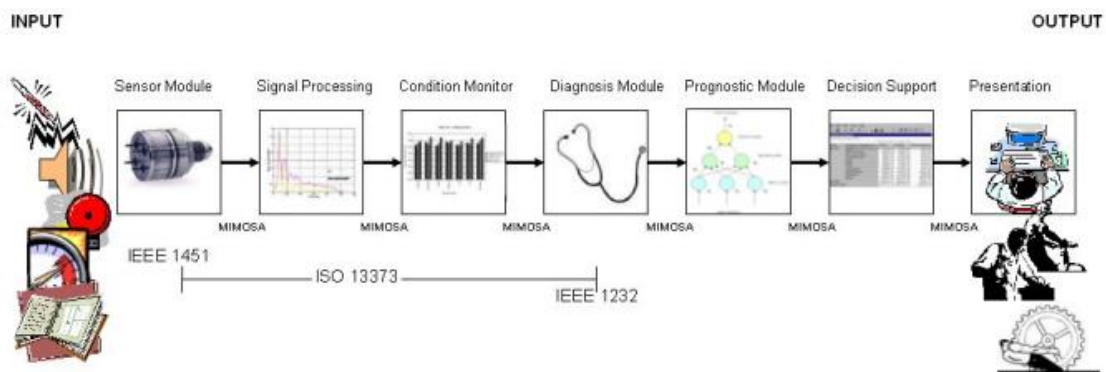

Fig 2. Standards in the CBM concept [11]

Vibration analysis as a predictive maintenance apparatus

Mechanical vibration analysis is a proven method to identify damage to rotating equipment [12]. Except in the design phase, vibration testing is also used to maintain the machine in condition. During machine operation, its parts wear out, which changes the dimensions of the parts. Changing the dimensions of the parts leads to an unbalanced one work and vibration generation. To avoid accidents, it is necessary to perform regular vibro-diagnostics of machines, in order to identify changes that have occurred as a result of the machine. By detecting the causes of increased vibrations before the occurrence of the fault, it is possible to prevent unplanned delays and accompanying consequences. Vibrodiagnostics is a non-destructive testing method. Its application does not require disassembly of the machine to detect a fault and it is not necessary to stop the work process to perform the measurement. Traditional vibration signal analysis has generally relied upon the spectrum analysis via the Fourier Transform. Fourier analysis transforms a signal $f(t)$ from a time-based domain to a frequency-based one, thus generating the spectrum $F(\omega)$ that includes all of the signal's constituent frequencies (fundamental and its harmonics) and which is defined as [13]:

$$F(\omega) = \int_{-\infty}^{\infty} f(T)e^{-i\omega t} dt \quad (1)$$

Fueled by its huge success in processing stationary signals in a wealth of application areas, an FT technique has enjoyed other interesting extensions. One such extension is in the particular area of vibrations and machine-health monitoring, called the fast Fourier transform (FFT)-based order analysis (OA) technique, including its order-tracking capability [14,15].

Testing of industrial fans using the method of vibrodiagnostics

As already mentioned, the application of the vibrodiagnostic method enables early detection of system failures. In this study, for example, are taken systems industrial fans that are implemented in a production facility “Zelezara Smederevo”. After the installation of the System and commissioning, after a certain time, there were visibly elevated vibrations on the fans, so the diagnosis had to be approached accordingly. The system is directly connected, that is, the connection between the electric motor and the fan is direct, so the diagnostics are approached in two measuring points of the fan drive itself. Figures 3. and 4 show the fan system and its drive.

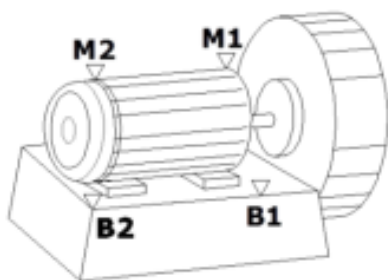

Fig 3. Measuring points



Fig 4. Fan

Table 1. Measured quantities before maintenance

Vibration: Veff [mm/s]-BNL [dB]							
Point	Vertical		Horizontal		Axial		RPM
M1	3,75	18	4,04	20	6,14	17	2951
M2	26,73	22	29,77	19	-	-	2950

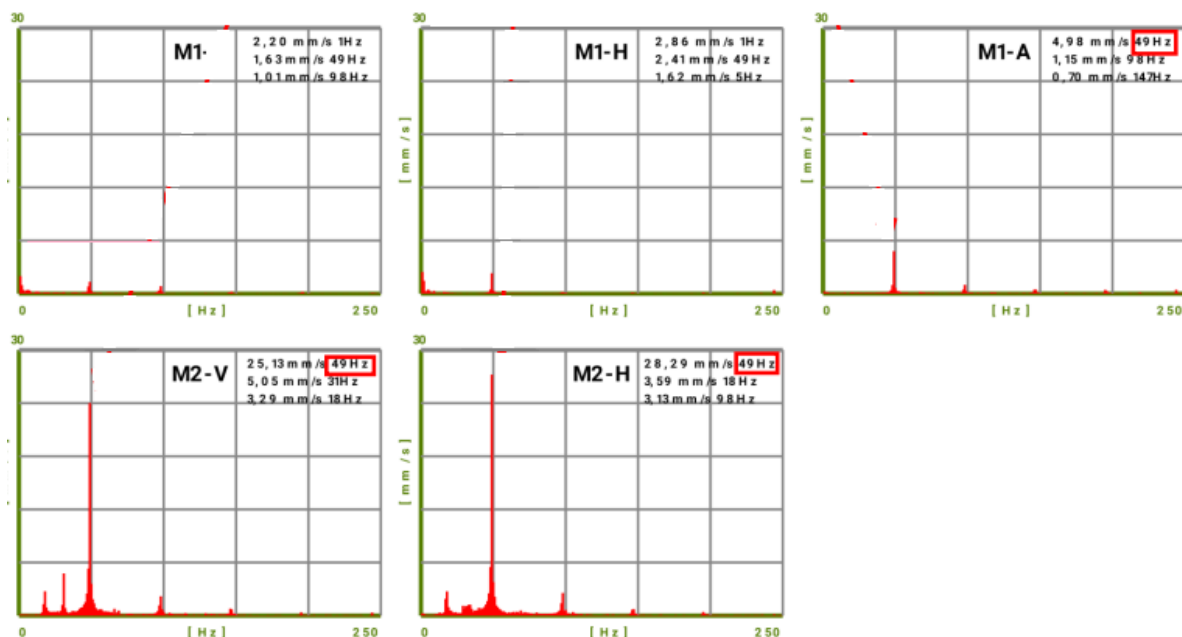

Fig 5. Vibration diagram in FFT mode

According to the measured values and the obtained diagrams, it can be concluded that the vibration level for this class of machines is significantly increased. The measured system belongs to the first class of machine power, because the electric motor has a power of 3 kW with a speed of 3000 min⁻¹. Permissible vibrations in this range up to 4.5 mm / s according to ISO 10816. From the diagram in Figure 5, it can be determined that 1X peak is expressed, at the frequency of the machine which is 50Hz, which further indicates that an unbalance occurs on the fan. After diagnosing and analyzing the problem, he started the process of establishing the unbalance and its point. Figure 6 shows the process of measuring the fan shaft unbalance.

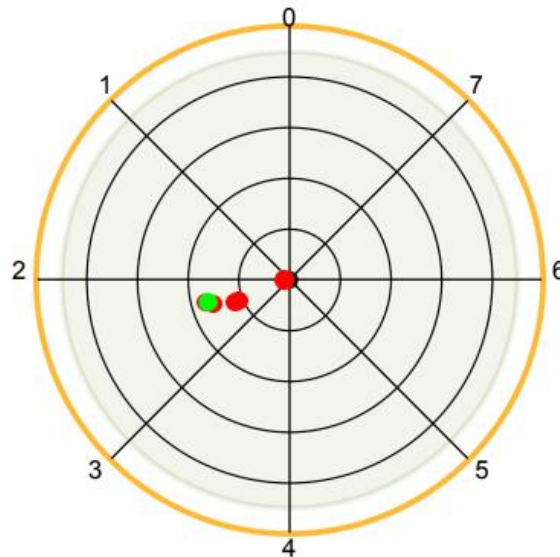

Fig 6. Unbalance fan shaft

The unbalance diagram shows the point escaping from the zero point where the system is in full balance, and based on that, the position at which it is necessary to install a counterweight is determined. After setting the counterweights, the vibrations are measured again and the balance point is determined. Table 2. shows the vibration values after the process of balancing the fan with the motor.

Table 2. Measured quantities before maintenance

Point	Vibration: Veff [mm/s]-BNL [dB]						RPM
	Vertical		Horizontal		Axial		
M1	1,19	15	0,96	20	1,41	11	2951
M2	1,62	16	1,29	23	-	-	2950

According to the data obtained after the balancing process, drastically smaller vibrations can be noticed, where vibrations of 1.19 mm/s are realized on the front bearing, while vibrations of 1.62 mm/s occur on the rear bearing. The vibrations on the rear bearing are naturally higher due to the fact that the electric motor does not have support on the rear part. After determining that the measured values are in a good range, the balance point check is approached.

Figure 7 shows the balance point after the industrial fan balancing process.

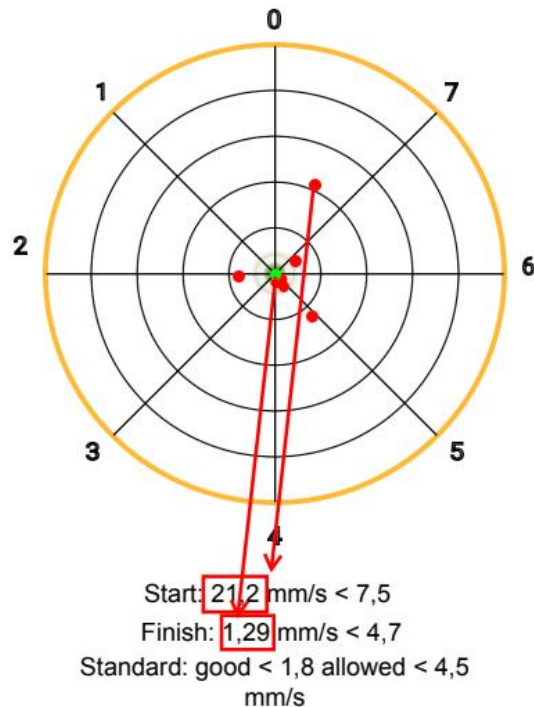

Fig. 7. Point after unbalance

As shown in the figure, it is clear that the balancing point has been brought to ideal zero, and it can be concluded that the balancing process has been done successfully, and that the vibrations have been brought to a satisfactory level.

CONCLUSION

It can be concluded that the CBM maintenance concept must be approached thoroughly and in detail, and that the concept should focus on a few basic steps and modules, i.e. on diagnostics and decision support. Most of today's systems are still not subject to serious maintenance concepts, and the main reason for such a case is the high level of financial investment in the diagnostic and maintenance system. With a detailed approach and cost analysis on a multi-year level, a picture is obtained, that quality system maintenance can save up to 40% of total production costs. The biggest problem of incomplete maintenance is reflected in unplanned production downtime, which is actually the biggest economic loss, and then the size of failures and their remediation. In order to avoid such things, to minimize them, the concept of maintenance according to the condition was introduced, with constant inspections and diagnostics of the system.

REFERENCES

- [1] Babić, M., Lazić, M., Principi definisanja alarma i limita stanja ulja u eksploataciji, VIII Internacionalna konferencija o Tribologiji, pp. 177-186, 2003.
- [2] Novaković, B., Radovanović, Lj., Pekez, J., Mere prediktivnog održavanja komponenti dizel električnih agregata, OTO 2018, pp. 59-63, 2018.
- [3] Rivera, D. L., Scholz, M.R., Fritscher, M., Krauss, M., Schilling, K., Towards a Predictive Maintenance System of Hydraulic Pump, IFAC-PapersOnLine, pp. 447-452, 2018.
- [4] Jardine, A. K., Optimizing condition based maintenance decisions, Annual Reliability and Maintainability Symposium, LA: IEEE, pp. 90-97, 2002.
- [5] Wetzer, J.M., Cliteur, G.J., Rutgers, W.R., Verhaart, H.F.A., Diagnostic - and Condition assessment-techniques for Condition Based Maintenance, Annual Report and Conference on Electrical Insulation and Dielectric Phenomena, pp.47-51, 2000.

- [6] Jardine, A. K., Lin, D., & Banjevic, D., A review on Machinery Diagnostics and Prognostics Implementing Condition-Based Maintenance, *Mechanical System and Signal Processing*, pp. 1483-1510, 2006.
- [7] Lee, J., Abujamra, R., Jardine, A.K.S., Banjevic, D., An integrated platform for diagnostics, prognostics and maintenance optimization, *Proceedings of the Intelligent Maintenance Systems* (pp. 15-27), 2004.
- [8] Voisin, A., Levrat, E., Cochetoux, P., Iung, B., Generic prognosis model for Proactive Maintenance Decision Support: Application to Pre-Industrial E-maintenance Test Bed, *Journal of Intelligent Manufacturing* 21(2), pp. 177-193, 2010.
- [9] Adamović, Ž., Radovanović, Lj., Modeli Održavanja na Bazi Tehničke Dijagnostike, *Tehnička Dijagnostika* 7(3), pp. 29-35, 2008.
- [10] Ilić, B., *Automatizovani Dijagnostički Modeli i Njihov Uticaj na Pouzdanost Tehničkih Sistema* (Doctoral dissertation), Tehnički fakultet "Mihajlo Pupin", 2016.
- [11] Bengtsson, M., *Condition Based Maintenance Systems –An Investigation of Technical Constituents and Organizational Aspects*, Västerås: Mälardalen University, 2004.
- [12] Zuber, N., Ličen, H., Mogućnosti primene metoda veštačke inteligencije u automatizaciji vibrodijagnostičkih metoda, *Tehnička dijagnostika*, 10(2), pp. 9-16., 2011.
- [13] Newland, D.E., *An Introduction to Random Vibrations, Spectral & Wavelet Analysis*, third ed., Dover Publications, 2005.
- [14] Al-Badour, F., Sunar, M., & Cheded, L., Vibration analysis of rotating machinery using time–frequency analysis and wavelet techniques, *Mechanical Systems and Signal Processing*, 25(6), pp. 2083-2101, 2011.
- [15] De Silva, C.W., *Vibration: Fundamentals and Practice*, Second ed., Taylor & Francis, 2007.

A BRIEF REVIEW OF THE APPLICATION OF THE SPM METHOD IN ORDER TO IMPROVE PREVENTIVE MAINTENANCE OF BEARINGS

Luka Djordjević¹, Borivoj Novaković¹, Jasmina Pekez¹,
Ljiljana Radovanović¹, Mića Djurdjev¹

¹University of Novi Sad, Technical Faculty "Mihajlo Pupin", Zrenjanin, Serbia
e-mail: luka.djordjevic@tfzr.rs

Abstract: One of the most important aspects of preventive maintenance is reducing the cost of maintaining and extending machines' service life. Any downtime of a particular machine entails the costs caused by the machine's inactivity as well as the costs of corrective maintenance, which are often many times more expensive than the application of some of the methods of preventive maintenance. By applying diagnostics as a preventive method, it is possible to predict the future failure of a particular element or assembly before a machine downtime/failure, which significantly simplifies maintenance, both on organizing maintenance and on the economic side. This paper gives a brief review of the SPM method's use to diagnose the bearing failure and its advantages.

Key words: SPM method, bearing, preventive maintenance, vibrations

INTRODUCTION

Maintenance policies are categorised into two main strategic streams: corrective and preventive. Condition Based Maintenance (CBM) is a subdivision of preventive methodology and is based on the belief that 99 per cent of equipment will evidence some sort of indicators prior to a fault develops. Through the utilisation of science and technology, CBM exploits the operating condition of assets to diagnose faults at early stages of occurrence, thus triggering proactive maintenance based on the need, [1].

One of the benefits of preventive maintenance is planning the moment of maintenance. By correctly choosing the method of testing the condition of an element, we can predict the replacement of an element that is currently operating within the allowable limits but is approaching the critical condition. This prevents the occurrence of major machine failures, reduces the cost of corrective maintenance as well as the cost of machine downtime due to the fault.

Proactive technical maintenance aims reducing the total volume of technique required servicing and maximizing service life equipment (i.e. the ideal creation of a "perpetual" machine, that do not require technical services), systematic elimination of the source of the defect [2]. Diagnostics of asynchronous motors is an area that is developing very intensively in world technical practice. The literature mentions various methods by which it is possible to establish a whole range of failures of asynchronous motors. Today's tendency of diagnostics is the use of methods that do not require stopping the induction motor, and one of those methods is the shock pulse method - SPM method [3,4].

BASIC CONCEPTS IN SPM METHOD

Vibrations

Vibrations are mechanical oscillations relative to the reference position. Vibrations occur as a result of dynamic forces in the moving parts of an asynchronous motor. The basic parameters of vibration are amplitude, speed and acceleration of vibration.

Vibrations in asynchronous motors are generally undesirable because [4,5]:

- intensify the process of wear of all moving elements,
- cause breakage of mechanical components,
- lead to the weakening of separable ties,
- lead to the failure of electronic components and systems,
- damage the insulation of the cables being touched,
- cause noise and

- cause damage and disease in humans.

Diagnostic

The basis of diagnostics is the comparison of actual and desired behaviours, i.e. engine parameters. Diagnostic parameters help us in that, and that is why it is crucial to choose the right ones. The diagnostic parameter is a measurable physical quantity (vibration, noise, temperature, etc.) present in the process of engine operation.

The parameter must meet the following requirements [3,6]:

- unambiguity of change,
- sufficient sensitivity to change and
- accessibility and ease of measurement.

The main benefit of diagnostics is reflected in [3, 6]:

- transition from corrective to proactive
- maintenance,
- reduction of the risk of material damage,
- increasing operational reliability,
- increasing the mean time between failures and
- minimizing unplanned downtime.

Bearings

Ball and roller bearings are among the most common and important elements in rotating machinery. Every rolling element or anti-friction bearing has a limited life which is strongly influenced by installation, operating condition and the maintenance it receives. Machine reliability, efficiency and safety depend on bearings functioning correctly [7].

Great attention is paid to the study of bearings and their improvement. Furthermore, if in production the dimensions of the bearings deviate minimally from the ideal dimensions, due to the action of forces acting on the bearing, over time there are deformations in the bearing which leads to an increase in vibration.

The service life of roller bearings is limited. Even if the loads they are exposed to are within the projected limits, sooner or later there will be material fatigue and bearing failure. The time period until the appearance of the first signs of fatigue is a function of the number of cycles and the magnitude of the load. The life of roller bearings is defined by the total number of cycles that the bearing can perform before the first signs of damage appear. This does not mean that the bearing is unusable after that moment. As a rule, from the onset of the first signs of damage to the final stop, there is a sufficiently long period of time to plan and prepare for bearing replacement [8].

Moreover, if it is expendable, it is rare for the bearing to perform its intended service life. Other factors often cause bearing failures. An overview of the reasons for bearing failure is given in Fig 1:

11: Causes of failure in rolling bearings (Source: antriebstechnik 18 (1979) No. 3, 71-74). Only about 0.35% of all rolling bearings do not reach expected life.

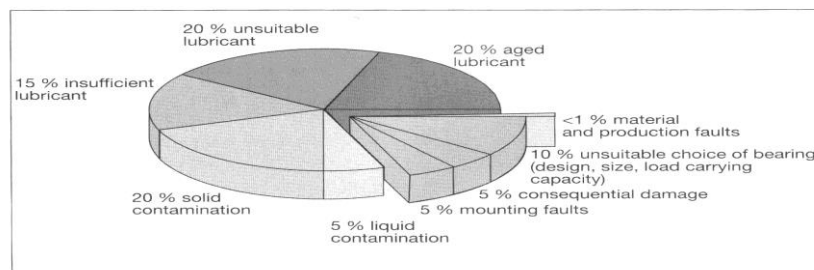

Fig. 1. Causes of failure in rolling bearing [9]

SPM Method

The SPM Method (S-Shock, P-Pulse, M-Method / Measurement) or shock pulse method is one of the methods used to monitor the condition of bearings. As it rotates, the bearing acts as a pulse generator. This method is based on extracting these impulses and monitoring their behavior.

In practice, this method has proven to be reliable. After years of testing through this method, the results obtained on all types of bearings and regardless of the age of the bearings were of the same quality [10].

In the shortest terms, the SPM method, i.e. the device (SPM meter), is used to detect the development of mechanical shock waves caused by the collision of two masses. The SPM method is based on phenomena in the material that occurs in a brief period of time immediately after the first contact of body particles [8, 7].

Figure 2. shows one of the SPM meters.

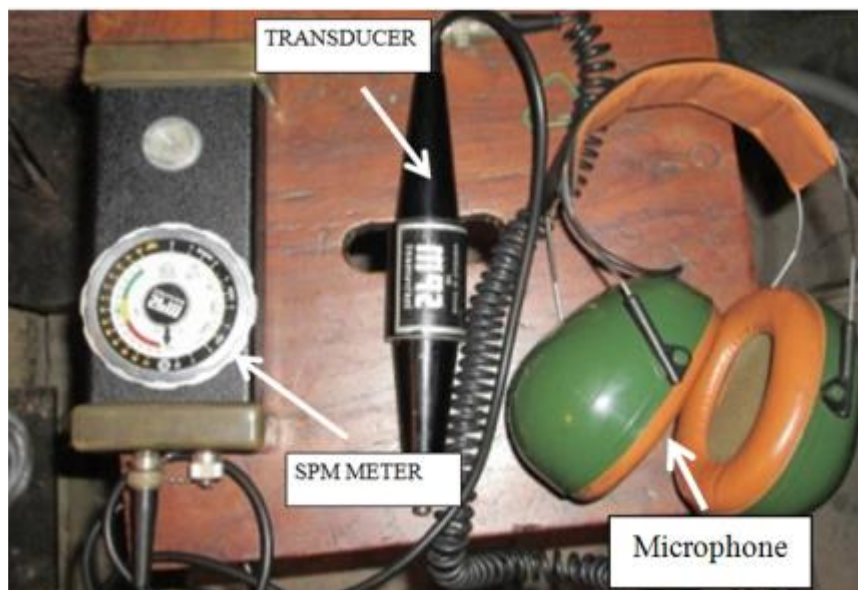

Fig. 2. Shock pulse meter 43A with transducer and microphone [11].

ANALYSIS OF PREVIOUS RESEARCH

In the Automobile factory “Zastava” in Kragujevac, 180 asynchronous motors were repaired in 2005. More than a quarter of the share in these failures was bearing failure. Table 1 shows the percentage of failures in asynchronous motors [3]:

Table 1. Percentage of asynchronous motor failures in the Automobile Factory, 2005

Failure	% of failures
Stator winding	12,94
Rotor winding	29,65
Stator assembly	11,34
Rotor assembly	13,25
Bearing	26,5
Other	6,32

Failures of asynchronous motors used in industry have a 40 to 90% share in failures and downtime due to bearing failures. The percentage of failures depends, of course, on the size of the machine [12].

In order to prevent machine downtime, it is necessary to react on time and to determine the condition of the bearings in an easy and tested way before the machine malfunctions/downtime. The SPM method can easily, and without interruption in engine operation, give the result of the bearing condition.

By applying the SPM method and obtaining results that show the values of bearing malfunctions or bearing failure, the cause of bearing failure should be discovered and analyzed. Not infrequently, even if the obtained values show poor bearing performance, the reason does not have to be the failure of the bearing itself.

Bearing damage is just one of the possible causes of poor operating condition. Therefore, when inspecting the bearings, generally speaking, the following basic elements should be kept in mind [3]:

- Carry out a detailed visual inspection of the bearing itself, with control of the clearance (wear of the bearing elements). Inspect other elements of the bearing assembly, ie. whether the connections of the parts are loose, whether there is a contact of the rotating parts on the housing or the bearing cover, whether there is damage to the parts and the like.
- Imbalance of rotational masses, work in the area of critical speed, preload or high load of the rolling bearing leads to poor operating condition. It is needed on the basis
- information on the existing vibration levels on the bearing housing, which are inspected, eliminate the cause of any increased vibrations (imbalance, mismatch, loosening of mechanical connection, etc.).
- Contamination of lubricants also leads to high values of the shock impulse. In any case, the lubricant should be replaced before the final decision on bearing replacement is made.

Less than 1% (0.35%) of all bearings perform their intended service life, and as many as 55% of the causes of premature bearing failure are inadequate lubrication. From this, we conclude that premature bearing failure could have been avoided by proper preventive maintenance [9]. Damages of bearings indicate most often downtimes of the production cycles and cause the high costs and losses, especially in the more expensive equipment [13]. Timely detection of a bearing defect can avoid unwanted conditions, primarily due to operative delays of machine systems and direct and indirect costs in this regard [14].

After obtaining results that indicate poor bearing performance, it is not necessary to replace the bearing immediately. We conclude from the above that we should first check other aspects that may affect obtaining this type of result.

After the checks, a new measurement must be performed. Depending on the obtained values, three cases can occur [3]:

- The measured value decreases to an acceptable level and no longer increases. The cause was not the bearing,
- The measured value decreases, but after a few hours it increases again. The cause is damage to the bearing,
- The measured value does not decrease. The causes are greater bearing damage.

CONCLUSION

The prevalence of bearings in the industry is enormous. There is almost no machine that does not have a bearing in it. Therefore, maintenance, and especially preventive maintenance, is an essential thing in extending the service life of the bearing and thus the part or machine in which it is located. Proper preventive maintenance entails savings by avoiding corrective maintenance, machine downtime, or major machine failure caused by bearing failure.

With little investment in a preventive maintenance system, verified bearing condition results can be obtained quickly and safely by applying the SPM method. Also, we must keep in mind the reasons for the failure of bearings, which in most cases can be removed very easily as a precaution.

The training and expertise of the person using the SPM method must be at a high level because early bearing replacement does not solve the specific problem of high impulse results, which will lead to a repeated replacement of the newly installed bearing in a short time, and thus unnecessary maintenance costs.

REFERENCES

- [1] Ruhul, A., Michael, P., Condition-based maintenance: a case study focusing on the managerial and operational factors, University College London, UK, 2014.
- [2] Desnica, E., Mikić, D., Palinkaš, I., Dijagnostika stanja kotrljajnih ležajeva na mašinskotehničkim sistemima, 26. Međunarodni znanstveno-stručni skup „Organizacija i tehnologija održavanja“, OTO 2017, Osijek, 2017.
- [3] Marjanović, Z., Brzaković, R., Krstić, D., Pобољшanje Kvaliteta Dijagnostike Asinhronog Motora Primenom Metode Udarnog Impulsa, Festival kvaliteta 2007, 34. Nacionalna konferencija o kvalitetu, Kragujevac, 2007.
- [4] Jeremić B. i saradnici: Osnovi vibrodijagnostike, skripta za seminar, Mašinski fakultet, Kragujevac, 2006.
- [5] Marjanović, Z., Brzaković, R., Pantelić Milinković, Z., Merenje Vibracije Asinhronog Motora, XII Konferencija sa međunarodnim ucescem, Nis, 2010.
- [6] Nandi, S., Toliyat, H. A: Condition Monitoring and Fault Diagnosis of Electrical Machines, IEEE Industry Applications Conference Thirty – Fourth IAS Annual Meeting, 1999.
- [7] SPM, The Shock Pulse Method for Determining the Condition of Anti-Friction Bearings, Technical Paper, 2002.
- [8] Šiniković, G., Detekcija Oštećenja Ležaja U Ultrazvučnom Domenu, Doktorska disertacija, Univerzitet u Beogradu, Mašinski fakultet, Beograd, 2012.
- [9] Engel, L., Winter, H.: Waelzagerschaden, Antriebstechnik, 18, Nr. 3., 1979.
- [10] Morando, L., Technology showcase : Integrated monitoring, diagnostic and failure prevention. Proceedings of a Joint Conference, Mobile, USA, 1996.
- [11] Gupta, R., Rastogi, V., Singh, R., Experimental Investigation Of Ball Bearing Lubrication Conditions By Shock Pulse Method, TRIBOLOGIA - Finnish Journal of Tribology 1-2 vol 36, Helsinki University of Technology, Finland, 2019.
- [12] Campo Barraza, S., Towards Autonomous Condition Monitoring Sensor Systems, Licentiate Thesis, Lulea University of Technology, Sweden, 2015.
- [13] Josifovic, D., Markovic, S., Damages And Possibilities For Regeneration Of Rolling Bearings, Faculty of Mechanical Engineering, University of Kragujevac, 2001.
- [14] Desnica, E., Djurdjev, M., Arsić, G., Test and control methods for bearings in mining exploitation for increasing system reliability, 27th International Scientific and Professional Conference "Organization and Maintenance Technology", OTO 2018, Osijek, 2018.

Session 4.

Oil and Gas Engineering

OIL PREPARATION AND HEATING FOR PIPELINE TRANSPORT

Jasna Tolmac¹, Slavica Prvulovic¹, Marija Nedic¹, Dragisa Tolmac², Vladimir Sinik¹

¹University of Novi Sad, Technical Faculty "Mihajlo Pupin", Zrenjanin, Serbia

²University Union - Nikola Tesla, Belgrade, Faculty of Management,
Sremski Karlovci, Serbia

e-mail: jasnatolmac@yahoo.com

Abstract: The paper presents the results of an experimental study related to the preparation of crude oil by heating, before introduction into the main oil pipeline. Crude oils that are very viscous (heavy crude oils) must be heated before being introduced into the pipeline. The content of paraffin in oil has a great influence on the properties of crude oil, and especially has an effect on reducing the flow properties of oil. By heating the oil, the flow properties are improved, the viscosity is reduced, as well as the friction pressure losses during transport by pipes. By heating the crude oil, the physical properties are modified, in order to prevent the formation of wax inside the pipeline. Based on experimental and theoretical research on a real oil pipeline, numerical values of the heat transfer coefficient through the oil pipeline (3), the amount of heat for heating oil in the tank (1) and the amount of heat for heating the oil pipeline (3) were obtained.

Key words: crude oil, oil heating, oil pipeline, heat transfer coefficient, heat losses.

INTRODUCTION

The analysis of the economics of transport of crude oil and its products by various modes of transport shows that the transport of these raw materials by pipelines is the most economical as soon as the annual transport capacity is above five million tons. This is especially noticeable when analyzing the supply of continental refineries with crude oil [4].

In order to ensure continual reception of crude oil from collection stations from oil fields, the main pumping station has a large reservoir space. At the main pumping station, the first introduction of transported oil into the pipeline is performed, as well as the control of physical properties, if this has not been done before [9,12].

Petroleum products are also transported from refineries to consumer centers by pipelines or mobile vehicles, which charging is mechanized and is performed by pipelines that have their own pumping station and other devices [2,11].

Support pumping stations are supplied with larger tank space and devices for heating crude oil. Support pumping stations are usually built along the route of the main oil pipeline near populated areas, electricity, water and sewage connections [6].

Main oil pipelines are most often buried in the ground at a depth of (0,8 – 1,35) m, measured from the ground surface to the upper edge of the pipeline. The depth of burial depends on the category of the oil pipeline and the width of the protective belts of populated areas, facilities near the pipeline, etc. Sometimes the main oil pipelines are laid above the ground on concrete pillars with a height of (0,50 – 0,75) m, [4,7].

Valves are installed along the route on every (10 - 15) km of the oil pipeline in order to prevent major oil losses, if for any reason the pipeline bursts. The damaged place is "blocked" by the valves between which it is located [7, 8].

Crude oils that are very viscous (heavy crude oils) must be heated before being introduced into the pipeline. This is done in the main and support pumping stations, which are equipped with boiler

rooms. Boilers are usually heat with the oil being transported, and the heating fluid is hot water or superheated water steam pressure of (10 - 15) bar, [1,10].

The purpose of the dispatch pump station is as follows [3,5] :

- at the pumping station, crude oil from collection stations is accepted in tanks,
- raises the pressure of crude oil,
- refines crude oil,
- regulates the pressure of crude oil in the main oil pipeline,
- measures the physical properties of crude oil.

The aim of this paper is to determine the heat transfer coefficient and flow regime in the pipeline (3), as well as the numerical values of heat consumption for heating oil in the tank (1) for various heating temperatures and numerical values of heat consumption for heating the pipeline (3).

MATERIAL AND METHODS

Experimental tests and measurements were performed on a real plant for storage and transport of crude oil. The scheme of the experimental plant is given in Fig. 1. Preparation and heating of crude oil is performed in the tank (1). The tank has a heater (7) with steam and a mixer (8). In the tank (1), the crude oil is preheated to the appropriate temperature (20 - 50) °C, depending on the paraffin content and the pour point. Oil is transported by pump (2) and an oil pipeline (3) with a diameter of 323/301 mm and a length of 1550 m. Using a pump (4) and a main oil pipeline (5) with a diameter of 457/428 mm and a length of 91000 m, crude oil is transported to the refinery. The oil pipelines (3) and (5) are isolated with polyurethane foam, the isolation thickness is 100 mm.

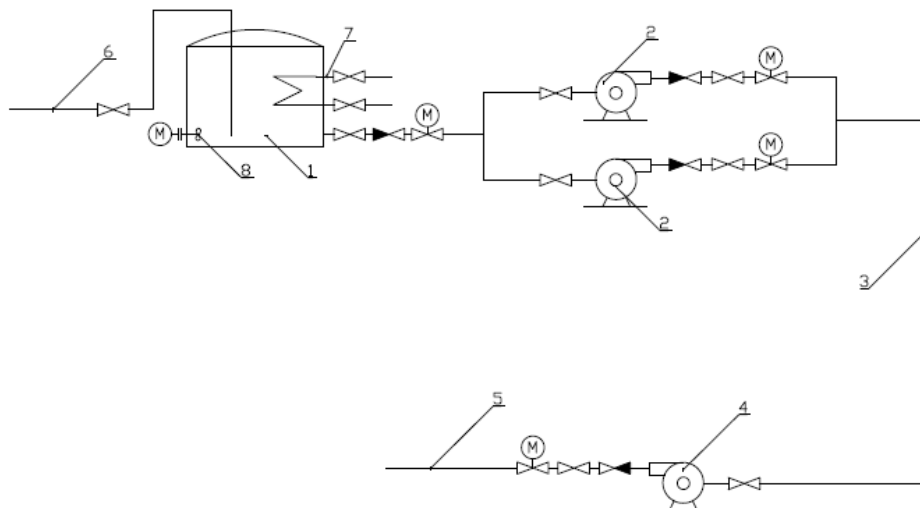

Fig.1. Scheme of the experimental plant, 1-reservoir, 2-centrifugal pump, 3-oil pipeline, 4-centrifugal pump, 5-the main oil pipeline, 6-crude oil supply, 7-heater, 8-mixer

At the maximum charging height $H_{\max} = 10$ m, there is 12560 m³ of oil in the tank, which corresponds to a mass of 10990 t. Characteristics of crude oil are given in Table 1. Characteristics of transported crude oil do not exceed the limit values given in the Table 1.

Table 1. Characteristics of crude oil

Property	Unit of measure	Values
Density at 15 °C	(kg/m ³)	875
Kinematic viscosity at +20 °C max.	(m ² /s)	23·10 ⁻⁶
Kinematic viscosity at +30 °C max.		18·10 ⁻⁶
Kinematic viscosity at +40 °C max.		15·10 ⁻⁶
Kinematic viscosity at +50 °C max.		11·10 ⁻⁶
Pour point	(°C)	max. + 8 max. +26
Imported oil		
Domestic oil		
Reid steam pressure max.	(kPa)	50
Water and sediments max.	(% v/v)	1
Sulfur content max.	(% m/m)	2,8

Both pumps (2) run simultaneously during transport. The heating of the oil pipeline (3) is done by two pipelines with a diameter of 25 mm, which are laid along the oil pipeline (3), through which water steam flows at a pressure of $p = 12$ bar, temperature $t = 200$ °C. The flow of oil is isothermal. Transport capacity ranges from 500 to 700 m³/h. The characteristics of the pump (2) are: $Q = 350$ m³/h - flow, $H = 75$ m - pump duty, $N = 132$ kW - pump power.

The main oil pipeline (5), 91000 m long, transports oil to the refinery. The flow of oil is non-isothermal. Depending on the temperature and transport capacity, the pressure at the beginning of the pipeline is $p_1 = (35 - 40)$ bar.

RESEARCH RESULTS

For the established values of crude oil flow, the values of Reynolds number, flow rate and heat transfer coefficients were determined and the results are given in Tables 2 and 3. Reynolds number $Re > 2320$, based on that it can be said that the flow is turbulent along the entire length of the pipeline (3).

Table 2. Flow mode, (temperature $t = 20$ °C, viscosity $\nu = 23 \cdot 10^{-6}$ m²/s)

1	Flow Q (m ³ /h)	500	560	600	640	700
	Specific flow q (m ³ /s)	0,139	0,155	0,167	0,177	0,194
2	Reynolds number Re	25625	28695	30782	32869	35869
3	Flow velocity V (m/s)	1,97	2,20	2,36	2,52	2,75

Table 3. Heat transfer coefficient, (temperature $t = 20$ °C, viscosity $\nu = 23 \cdot 10^{-6}$ m²/s)

1	Flow Q (m ³ /h)	500	560	600	640	700
2	Reynolds number Re	25625	28695	30782	32869	35869
3	Heat transfer coefficient to the pipeline α_i (W/m ² K)	209	229	242	253	271
4	$\alpha_i \cdot D_{ci}$ (W/mK)	63	69	73	76	81
5	Heat conduction coefficient kD_m (W/mK)	0,178257	0,178301	0,178326	0,178343	0,178369

6	Heat transfer coefficient k (W/m ² K)	0,433188	0,433295	0,433356	0,433397	0,433460
---	---	----------	----------	----------	----------	----------

The amount of heat for heating the oil in the tank (1), depending on the heating temperature, is given in Table 4.

Table 4. The amount of heat for heating the oil in the tank (1), $V_R = 12560 \text{ m}^3$

		$t = 20 \text{ }^\circ\text{C}$	$t = 30 \text{ }^\circ\text{C}$	$t = 40 \text{ }^\circ\text{C}$	$t = 50 \text{ }^\circ\text{C}$
1	The amount of heat for heating the oil in the tank Q_R (kJ/h)	$32,4 \cdot 10^6$	$32,6 \cdot 10^6$	$33,14 \cdot 10^6$	$33,80 \cdot 10^6$
2	Heat losses Q_g (kJ/h)	$0,25 \cdot 10^6$	$0,27 \cdot 10^6$	$0,33 \cdot 10^6$	$0,40 \cdot 10^6$
3	Total amount of heat $Q = Q_R + Q_g$ (kJ/h)	$32,65 \cdot 10^6$	$32,87 \cdot 10^6$	$33,47 \cdot 10^6$	$34,20 \cdot 10^6$
4	Heating time τ (h)	3	6	12,5	20
5	Amount of water steam G_p (kg/h)	11765	11845	12061	12324
6	$q_p = G_p / V$ (kg/m ³ h)	0,937	0,943	0,960	0,981
7	Total amount of water steam $G_{puk} = G_p \cdot \tau$ (kg)	35295	71070	150762	246480
8	Heat power of heater Q_{gr} (kW)	9070	9130	9300	9500

After the introduction of oil into the pipeline (3), i.e. during transport, the oil cools and transfers its heat to the environment. The heat consumption for heating the pipeline (3) is given in Table 5. The upper level of oil in the tank (1) is $H_{max} = 10 \text{ m}$, and the lower level is $H_{min} = 2 \text{ m}$. At a maximum flow of $700 \text{ m}^3/\text{h}$, the pumping time is $\tau = 15 \text{ h}$.

Table 5. Amount of heat for heating the oil pipeline (3), external diameter $D = 323 \text{ mm}$, and length $l = 1550 \text{ m}$

		$t = 20 \text{ }^\circ\text{C}$	$t = 30 \text{ }^\circ\text{C}$	$t = 40 \text{ }^\circ\text{C}$	$t = 50 \text{ }^\circ\text{C}$
1	Heat losses Q_g (kJ/h)	86248	143750	191595	239570
2	Amount of water steam G_p (kg/h)	31	51	68	85
3	$q_p = G_p / l$ (kg/mh)	0,020	0,033	0,044	0,055
4	Total amount of water steam $G_{puk} = G_p \cdot \tau$ (kg)	465	765	1020	1275
5	Heat power Q_g (kW)	24	40	53	67

CONCLUSION

The paper presents the results of experimental and theoretical research of crude oil transport parameters. For the given values of crude oil flow, the values of Reynolds number, flow velocity and heat transfer coefficient were determined. Numerical values of the amount of heat for heating oil in the tank (1) were determined. Numerical values of the amount of heat for heating the oil pipeline have also been determined (3).

It was found that: the heat transfer coefficient through the pipeline (3) is $k = 0,433 \text{ W/m}^2\text{K}$. The thermal power of the heater (7) is 9300 kW. The consumption of water steam for heating the oil pipeline (3) is in the range (31 - 85) kg/h.

REFERENCES

- [1] Danilovic, D., Karovic-Maricic, V., Ivezić, D., Batalovic, V., Živković, M., Leković, B., Crnogorac, M. : Analysis of applied heating systems for heating well pumps for the transport of paraffin oil in the fields of oil industry of Serbia, *Technique*, 67: 919-923, 2012.
- [2] Rukthong, Wanwisa, Piumsomboon, Pornpote, Weerapakkaron, Wichapun. : Computational Fluid Dynamics Simulation of a Crude Oil Transport Pipeline: Effect of Crude Oil Properties. *Engineering journal*,; 70: 145-154, 2016.
- [3] Hussain H. Al-Kayiem, Wong Ning, Nassir Dhamin Mokhlif. Characterisation of paraffinic compositions in crude oils. *International Journal of Oil, Gas and Coal Technology*. 2017; 15 (2).
- [4] Prstojevic, B. : Pipeline transport of oil and gas, Faculty of Mining and Geology, Belgrade, 2012.
- [5] Prvulovic, S., Tolmač, D. : Transportation Systems - a collection of solved tasks, Technical Faculty "Mihajlo Pupin", Zrenjanin, Serbia, 2012.
- [6] Sun, Guangyu; Zhang, Jinjun; Me, Chenbo; et al. : Start-up flow behavior of pipelines transporting waxy crude oil emulsion, *Journal of Petroleum Science and Engineering*, 147: 746-755, 2016.
- [7] Tolmac, J., Prvulovic, S., Nedic, M., Tolmac, D. : Analysis of the main parameters of crude oil pipeline transport , *Chemical industry*, Vol. 74, No. 2, pp. 79-90, 2020.
- [8] Secerov-Sokolovic, R., Bjelovic, Z., Sokolovic, S. : Influence of solid paraffin content on the rheology of model oil, *Chemical industry*, 60: 10-14, 2006.
- [9] Tanaskovic, P. : Transportation of Crude Oil and Gas, Part I, Faculty of Mining and Geology, Belgrade, Serbia, 1998.
- [10] Jie Sun, Jiaqiang Jing, Cheng Wu, Fei Xiaoa, Xiaoxuan Luo. : Pipeline transport of heavy crudes as stable foamy oil, *Journal of Industrial and Engineering Chemistry*, 44: 126-135, 2016.
- [11] Nedic, M., Tolmac, J., Prvulovic S., Tolmac, D. : Using the renewable energy sources in Serbia and in the world, International scientific conference: TECHNOFORUM 2019 - Research trends in agricultural engineering and eco-energy Institute of Agricultural Engineering and Computer Science, pp.1-8, Faculty of Production and Power Engineering, University of Agriculture in Krakow, 13 – 15 May 2019.
- [12] Tolmač, J., Prvulović, S., Nedić, M., Aleksić, A., Tolmač, D. : Analysis of the influence of physical characteristics of crude oil in pipeline transport, *International Congress on Process Industry*, Vol.32, No.1, pp.105-109, 30-31. maj 2019, Belgrade, ISBN 978-86-81505-94-6.

TESTING AND CONQUERING INTERVAL TECHNOLOGY ON THE WELL

Milan Marković¹, Zvonimir Bošković¹

University of Novi Sad, Technical Faculty "Mihajlo Pupin", Zrenjanin, Serbia

e-mail: milanzrmarkovic@gmail.com

Abstract: When performing overhaul works in exploration and contour - exploration wells, three phases can be defined: preparation of the well for opening the interval, opening of the interval and conquest of the well after cracking. The preparation of the well for opening the interval includes the installation of the eruption device and safety equipment, testing the tightness of safety equipment and wells (protective pipes), cleaning the well to the impact pole, recording CCL (measuring the depth of couplings of the production column) and CBL (measuring the quality of cement stone behind the exploitation column), as well as the interpretation of the recorded diagrams, especially the CBL for the decision on possible overhaul cementation. As for opening the interval, it is important to determine the right way to shoot it (if it is possible to always open the interval under pressure), select the appropriate negative differential pressure, select the number and radial arrangement of perforation channels and select the type and strength of explosive charge. Conquering the well after cracking can be: eruptive, clipping, replacement of the working fluid with nitrogen and DST (Drill Stem Testing).

Key words: interval opening, cracking, eruption device, safety equipment, tightness test, impact plate, CCL, CBL, eruptive, clipping, DST.

INTRODUCTION

Before opening a potentially productive interval, it is extremely important to test the well in order to better prepare it. Preparation includes equipping the well both on the surface and inside it, testing the well and pressure equipment and conducting various measurements (CCL, CBL ...). It must also be taken into account that, depending on the conditions prevailing in the well, whose data were obtained by testing, determine the right strength of the explosive charge, the diameter of the perforator (shotgun) and the method of cracking (overbalanced or underbalanced). After cracking, the appropriate method of conquest is chosen, which also depends on the conditions in the well, so as not to damage the productive interval, clogging them with a sand "plug" due to the great depression.

MATERIAL AND METHODS

Installation the eruption device

After the installation of the overhaul plant, the eruption device (EU) is installed. EU mounted with the following data and characteristics: 244.5 x 139.7 x 73.02 mm for 207 bar. The EU is part of the equipment of the wellhead, on which the tubing column is hung, it enables the creation of pressure at the bottom, as well as the measurement of the pressure in the casing and at the outlet of the fluid from the well. It consists of:

- a) End flanges,
- b) Tubing head and
- c) Eruption tree (christmas tree)

End flanges – is the lower part of the EU, has the task of connecting all the protective columns with each other and to ensure the tightness of the space between the columns.

Tubing head – is the middle part of the EU, its interior is adjusted so that one or two rows of tubing can be hung.

Eruption tree – is the upper part of the EU, controls and regulates the eruption of the well, directs the outflow of fluid into a certain drain pipe and, if necessary, closes the well [4].

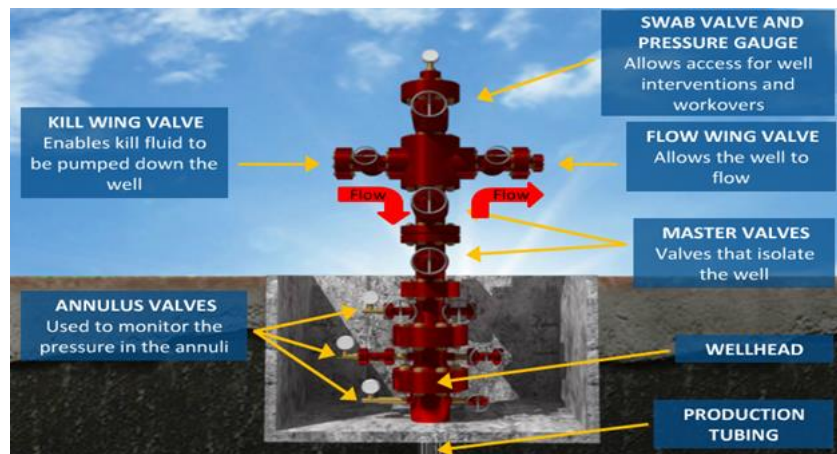

Fig. 1. Eruption device [4]

Installation of safety equipment

After the eruption device is installed, the safety equipment is installed, as follows: jaw and spherical preventer of working pressure higher than the bearing.

Spherical preventers – Are devices that can seal around any piece of equipment in the well that is currently in the preventer zone or completely close the full profile of the wellbore channel. The pressurized oil pushes the piston and allows the preventer to close or open. Rubber seals shrink under pressure and close the space around the bars, regardless of the dimensions of the bar, that is the full profile of the well.

Jaw preventers – They are made of the same dimensions and working pressures as spherical preventers. In addition to the hydraulic closing-opening system, they must also be equipped with a mechanical system ("U" joints, rods and a wheel with a protective wall). If equipped with side openings, they can be used to connect to water for choking and damping. The closing of the interspace is achieved with two sleeves - seals whose front sides are semicircular with a diameter equal to the outer diameter of the drill rods. By tightening these sleeves, complete impermeability around the bars is achieved [5].



Fig. 2. Jaw preventer [5]

The pressure tightness test of safety equipment

The pressure tightness test of the preventer assembly is performed in two stages: Under low pressure (15 – 20 bar) for 3 min; under high pressure with the prescribed pressure and

duration. The low pressure test is performed in order to detect possible leakage of sealing surfaces, because high pressure increases the closing efficiency. The test under high pressure is performed as follows: The jaws of the full profile are tested under the pressure determined for testing the corresponding column of protective pipes, that is with the value of the working pressure of the preventer assembly. A lower value applies. The test time is 30 minutes and the allowable pressure drop is 10%. Preventive high pressure assemblies are usually tested using a "cup tester". The "cup tester" separates the test area of the wellhead from the column of protective pipes, that is the exposure of the column of protective tubes to a pressure higher than allowed is prevented. When the preventer assembly is tested using a "cup tester", the test time is 15 minutes and pressure drop isn't allowed. If the safety equipment is not airtight, eliminate the cause of the airtightness, and then re – examine it for airtightness [3].

Well equipping

Introductory column – is the first protective pipe that is installed in sedimentary rocks. The primary task of the introductory column is to cover and prevent collapse from the upper loose deposits of humus, gravel or sand. Technical column - Wells where formations with increased pore pressure are expected, zones with mud losses, unstable sections of shale clays or sections of salt, which are usually deeper wells, require the installation of one or more rows of technical columns. This column aims to protect the borehole channel until it reaches the desired depth. The main task of the technical column is to control the formations with increased pore pressure, so that this column covers the shallower layers with reduced or normal pore pressure. This function is necessary, because the high density of mud needed to control the zones with increased pressures can cause loss of circulation or tool jamming. Exploitation column - It is installed through productive series (20 – 50m below), when exposed layers need to be examined or when these layers are positive in terms of layer fluid production. The main function of this column is the protection of the productive layers in case of leakage, that is tubing damage in the production phase. Also, this column enables the replacement of production equipment in the well during the service life of the well [1].

One – stage cementation

One – stage cementation – is the raising of the cement slurry to the planned height in the space between the protective pipes and the wall of the well in one operation, in the following order of procedures:

- a) After installing the protective pipes in the well, the well channel is cleaned by rinsing, that is the clay lining (mud cake) is removed from the walls of the well with scrapers and centralizers, in order to achieve better contact between the cement and the well wall.
- b) On the cementation head, the first lower plug is released and a cement slurry is pressed which pushes that plug all the way to the impact plate where the plug stops. Then there is an increase in pressure that breaks through the membrane on the plug and the cement slurry passes through the plug, the impact plate, the heel of the column and enters the interspace.
- c) The second upper plug is released on the cementation head, which is pushed to the first plug with mud or water.
- d) The second plug cleans the inside of the protective pipes from the remaining cement slurry and when it lands on the first plug, it prevents further injection of mud inside the column. The increase in surface pressure means that the second plug has settled on the first, which also represents the end of one – stage cementation [1].

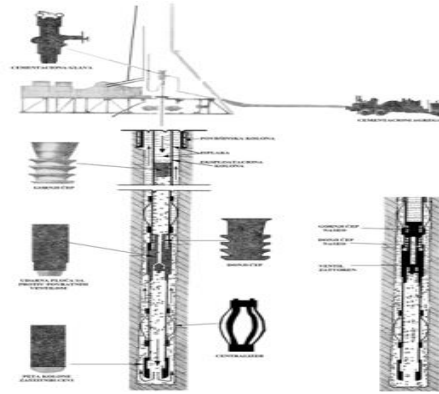

Fig. 3. Scheme of performing one – stage cementation [1]

CBL

CBL – The application of conventional logging to determine the quality of cement stone is based on the fact that the acoustic waves transmitted through the wall of the protective pipes into the well are weak if the column of protective pipes is coated with cement. The emitted acoustic waves propagate through the protective tube column, through the fluid behind the protective tube column and through the formation. Each of the mentioned media has a different propagation time of longitudinal waves. The longitudinal wave propagates the fastest through the column of protective tubes, and the slowest through the fluid. Conventional instruments for measuring the quality of cement stone use ultrasonic waves of lower frequencies (20 – 30 kHz) with a distance between transmitter and receiver of 0.91 m and 1.52 m. The closer receiver is used to assess the quality of the realized cement lining along the column of protective pipes (the amplitude of the first nail of the acoustic wave is registered), and the further one, to evaluate the quality of the realized cement lining with formation, registers the transit time and the total acoustic wave signal [4].

Technique and technology of opening production intervals

Perforation is a method of establishing communication between the wellbore and reservoir channels in order to enable fluid production. High explosives are mainly used, the choice of which depends on pressure, temperature, energy (speed) and power (for example – cumulative explosive charge power $U = 4185 \text{ J / kg}$, $t = 3000 - 60000 \text{ C}$). Initiation of explosives can be:

- a) Mechanical (the weight that initiates the capsule descends from the surface) i
- b) Electrically (cable is lowered from the surface).

There are two basic types of perforation depending on whether the perforators are lowered to the tubing or to the cable. Perforators can be:

- a) Hermetic (explosive charge is not in contact with the fluid) and
- b) Non – hermetic.

The conventional way of opening productive intervals is done by using explosive cumulative charges and rifles with bullets. Conventional ways of perforation can be:

- a) Overbalanced and
- b) Underbalanced.

Overbalanced perforation – There is a working fluid (mud, salt water) in the well whose pressure p_1 is higher than the pressure of the formation p_2 , that is the differential pressure is positive. There is a preventer at the mouth of the well. A 4" diameter rifle is lowered into the column (for a 7" – 9" column) and perforated. During perforation, the perforations can become clogged with the solid phase from the mud, while the mud filtrate goes into the layer (pollution of the wellbore zone), so after the conquest, a small number of perforations are in production.

Underbalanced perforation – It is characterized by negative differential pressure, that is there is a fluid in the well whose hydrostatic pressure is less than the formation pressure. The well is fully equipped for production (tubing, packer, eruption device ...). The water in the well is a 2% solution of KCl (KCl prevents disruption of the system containing clay - it performs a cationic exchange of swelling of the clay). The small barrel rifle is lowered with a cable through the tubing. Due to $p_2 > p_1$, the well is put into production after firing without prior conquest [4].

Conquering the well after firing - by clipping

Conquering the well by clipping – The order of work operations with this method is as follows: first the well is cracked, then a tubing is installed in it, and then the well mouth is equipped, the piston is lowered into the well through an open eruption device. By lifting the piston, the column of liquid above the piston is pulled out. The piston is lowered to 20 – 30 m below the liquid level during operation. Conquering a well by clipping consists of gradually lowering the fluid level and increasing the depression at the bottom of the well. Conquest of the well is done with the well mouth open. Therefore, the application of this method comes into consideration when there is no danger of well eruption. Clipping must gradually lower the level, because otherwise sand may penetrate from the layer and create a sand plug due to a sudden depression. The piston is a hollow tube with a ball valve at the bottom of the piston. There are rubber cuffs on the piston that are reinforced with steel wire, which lift the fluid (mud, water) and take it out of the well. Often, a heavy rod is placed in the tubing above the piston, which by its weight enables the piston to fall faster through mud or water or thick oil. The disadvantage of this method of conquest is the impossibility of cleaning the bottom of the well from the sand that comes from the production formation [2].

RESULTS AND DISCUSSION

WELL TECHNICAL DATA

Final well depth:	1450,00m
Tube:	
- Introductory column D = 355,6mm	20,00m
- Technical column D = 244,5mm x 47,99kg /m, H40	400,00m
- Exploitation column D= 139,7mm x 20,79kg/m, K-55, cemented from bottom to 150m (250 m overlapping with the technical column)	1449,50m
- Anti – check valve	1437,10m
- Cementation heel	449,00m
- Impact plate	1424,00m

Shooting intervals:

1422,00 – 1415,00m, expected temperature 87 ° C, expected layer pressure 140 bar

Mounted eruption device:

244,5 x 139,7 x 73,02mm for 207 bara

Based on these data, we can conclude that:

- There is no "Open Hole",
- There is no "Liner" column and
- One – stage cementation was performed.

H – 40 i K – 55 –According to the API standard, the quality of protective pipes is marked with "Grad". "Grad" classifies columns for protective pipes according to the minimum limit of elasticity, so that according to the task for our columns we have the following "Gradove": For technical column H – 40, minimum limit of elasticity 40 000psi; and for the K – 55 exploitation column, the minimum elastic limit is 55,000 psi [1].

The firing interval is at least 2m above the impact plate, which can be concluded on the basis of data (1422 – 1415m firing interval, and the impact plate is at 1424m), as well as to perform an overbalanced perforation mode (positive differential pressure).

CONCLUSION

In order for a well to start producing fluid through productive intervals without possible problems, which can occur if all procedures for testing, equipping and conquering the well are not followed, it is necessary to determine the exact characteristics and conditions prevailing in the well. From that, which will protect the protective pipes, whether they will be cemented with one – stage or two – stage cementation, which preventer assembly should be installed (what working pressure and what diameter), also what equipment should be installed in the well, then after cementing CBL in order to determine the quality of cement stone in order to decide on possible overhaul cementation, and so on. These are all testing and equipping procedures. After that, it is important to choose the right way to shoot and conquer so that the well can start producing.

REFERENCES

- [1] Bizjak, R. Tehnologija bušenja sa projektovanjem, Novi Sad 2004.
- [2] Pavel, K., Osvajanje bušotina teorija i praksa, Priručnik za osvajanje hidrogeloških bušotina
- [3] Kontrola-izgradnje-busotina-materijal.compressed.pdf, rggf.untz.ba
- [4] Bošković, Z., Remontni i stimulatívni radovi u istražnim i konturno – istražnim bušotinama, Presentation
- [5] Tehnologija izrade bušotina I, Inženjerstvo nafte i gasa, RGF.

INCREASING THE QUALITY OF SEPARATION IN THE PHASE OF PREPARATION OF OIL FOR TRANSPORT

Milan Marković¹, Jasmina Perišić²

¹University of Novi Sad, Technical Faculty "Mihajlo Pupin", Zrenjanin, Serbia

²UNION University "Nikola Tesla", Faculty of Entrepreneurial Business and Real Estate Management, Cara Dušana 62-64, Belgrade, Serbia

e-mail: milanzmarkovic@gmail.com

Abstract: In order to prepare oil for transport, it is necessary to extract certain amounts of dissolved gas, water and various impurities. The extraction of gas from oil begins already in the reservoir, and then in the well due to the reduction of pressure (depression). Further separation of the gas and liquid phases is achieved by the following technological processes: separation of oil (separation of gas and liquid), dehydration of oil (separation of formation water and oil) and storage of oil. Oil transport is divided into domestic transport, which includes the phase of oil collection and preparation as well as the main transport, defined as the transport of oil from dispatch stations to the central dispatch station. The final phase of transport is transport from shipping stations to refineries. There are one-stage and multi-stage separation. In order for the oil to be better prepared for transport, it is necessary to increase the quality of the separation itself, and this is achieved by installing additional equipment, such as: defoamers, vortex breakers, coalescers and droplet traps, droplet traps in emulsions and sand washing system. In order to achieve the highest possible quality of separation, it is necessary to understand that in the entire system of internal collection of oil and gas, collection stations have the most important role. Their task is to collect the produced oil and gas from a certain number of wells, to separate the gas from the oil, individually and collectively measure these fluids, store the oil and transport it to the loading station, as well as transport the gas to the compressor station and other consumers.

Key words: petroleum, transport, oil separation, oil dehydration, oil storage, single stage separation, multistage separation, defoamers, vortex breakers, coalescers and droplet traps, droplet traps in emulsions, sand washing system, collection station.

INTRODUCTION

Oil and gas collection means the entire transport of oil and gas in the field, from wells to loading stations. The collection systems used for this can be divided into two large groups: open and closed. Due to their great advantages, only closed oil and gas collection systems are used everywhere in the world today. The companions of oil are natural gases (methane, ethane, propane, butane), it can be accompanied by nitrogen, hydrogen, carbon monoxide, salt water (it has a corrosive effect). Crude oil must be refined before use. According to its chemical composition, oil is a mixture of hydrocarbons such as alkanes, cycloalkanes, aromatic hydrocarbons, benzene. Some oils also contain iron, nickel and molybdenum (catalytic poisons). The mixture of oil and gas extracted from the wells is collected at appropriate places (measuring or collection stations) where the separation of the liquid and gas phases is performed. How many collection or measuring stations there will be in the oil field will be determined, first of all, by the distance and number of wells, as well as the amount of wells. After separation and measurement, the gas is shipped through a low-pressure gas pipeline and subjected to transport preparation processes. The liquid remaining after separation contains not only oil as the desired product of separation, but also a certain amount of water produced. In the last few years, world demand for crude oil has increased by approximately 38% - from $9.55 \cdot 10^6 \text{ m}^3 / \text{day}$ in 1985, to $13.13 \cdot 10^6 \text{ m}^3 / \text{day}$ in 2004 [4]. To the amount of oil produced is accompanied by an equal or greater amount of free water and bound water, which forms emulsions with the oil.

MATERIAL AND METHODS

Oil collection

Collection, as one of the basic functions of the collection – transport system, implies the transport of liquids from individual wells to a common location where preparation for transport is performed. The fluid is transported either by individual oil pipelines or collector pipeline systems, which mostly depends on factors such as reservoir size, terrain morphology, well layout and number, as well as the dynamic pressure at the wellhead. The mixture of oil and gas extracted from wells should be directed to measuring or collection stations where the separation of gas and liquid phases is performed, measurement of extracted quantities of oil and oil gas and oil storage if it is a collection station.

There are three systems for collecting a mixture of oil and gas:

- a) individual system,
- b) a system of separate pipelines or multiple measuring or collecting stations, and
- c) collection system [6].

Oil preparation

In order to prepare oil for transport, it is necessary to extract certain amounts of dissolved gas and water. Extraction of gas from oil begins already in the reservoir, and then in the well due to the reduction of pressure. Further separation of gas and liquid phases is achieved by the following technological processes:

- a) separation of oil (separation of gas and liquid),
- b) dehydration of oil (separation of formation water and oil) and
- c) oil storage [6].

Oil separation

The final phase of separation takes place in separators at a certain constant pressure and constant temperature. Separators are devices that separate gas and liquid (oil + water).

The efficiency of the separator is determined by the phase equilibrium, which is primarily influenced by the pressure, temperature and composition of the mixture, but also by the appropriate structural elements within the separator that ensure better separation of the liquid and gas phases.

Extraction of gas from oil takes place in two ways, basically following the same ways of separation that occur in the reservoir itself. The first way is the contact separation of the gas phase, during which the liquid and gas phases are in constant contact. The process is caused by a change in pressure and temperature, and the significance of this separation is the molecular action in which a part of medium-heavy hydrocarbons passes from the liquid to the gas phase.

Another way is the differential separation of the gas phase in which there is no contact of two separate phases, but the formed gas phase is completely separated from the process. The simplified principle of such separation is based on the gradual reduction of pressure, during which gas is released while the entire amount of medium and heavy hydrocarbons remains in the liquid.

In the separator, there is a one-stage separation and a multi-stage separation. One-stage separation is identical to the contact separation of gas and liquid phase due to the fact that it is performed in a closed system with a change in temperature and maintaining a constant pressure. Separation is performed in one or more parallel separators within which there is no

change in phase equilibrium. Multi-stage separation takes place in line-mounted separators with different pressures and different temperatures [3].

One-stage separation

The process takes place in one or more parallel separators in which the same pressure and temperature prevail. The phases that are formed in such conditions are in contact all the time of separation and there is no change in the composition of the mixture. Therefore, the conditions under which phase equilibrium occurs remain the same throughout the process. The characteristic of such separation is the increased amount of gas phase enriched with heavier hydrocarbon components. Thus, one-stage separation can be equated with flash gas degassing from oil. Since this is the only, and thus the last stage of separation, oil and gas are sent from the separator for further processing, storage or transport [5].

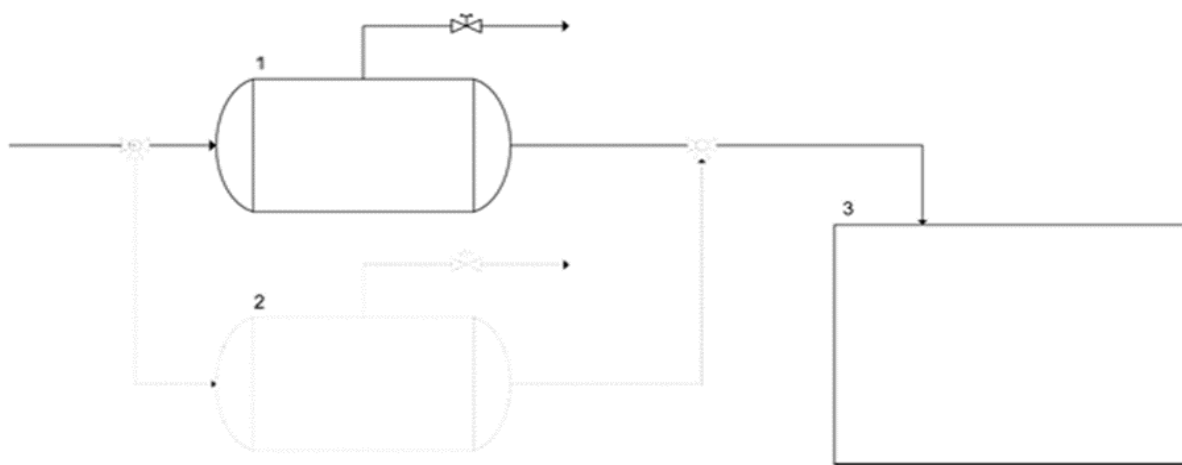

Fig. 1. Composition of equipment in single-stage separation [5]

1. separator;
2. possible additional separator for larger quantities of mixture;
3. tank.

Multistage separation

In this case, the mixture obtained from the well goes through several stages of separation. Each stage is characterized by a different, lower value of pressure and temperature at which gas escapes from the oil (Figure 2). Since gas and liquid phases are formed inside the separator, one of them is separated from the process. The rest of the mixture, which is no longer of the same composition, is then sent to the next stage of separation. The procedure is repeated as many times as the degree is defined by the process. Several comparative separators can be used for each stage, depending on the amount of fluid. This principle can be equated with the differential or gradual release of gas from oil. The characteristic of this method is reflected in the gradual reduction of the pressure of the mixture and finally in a larger amount of the obtained liquid phase [4].

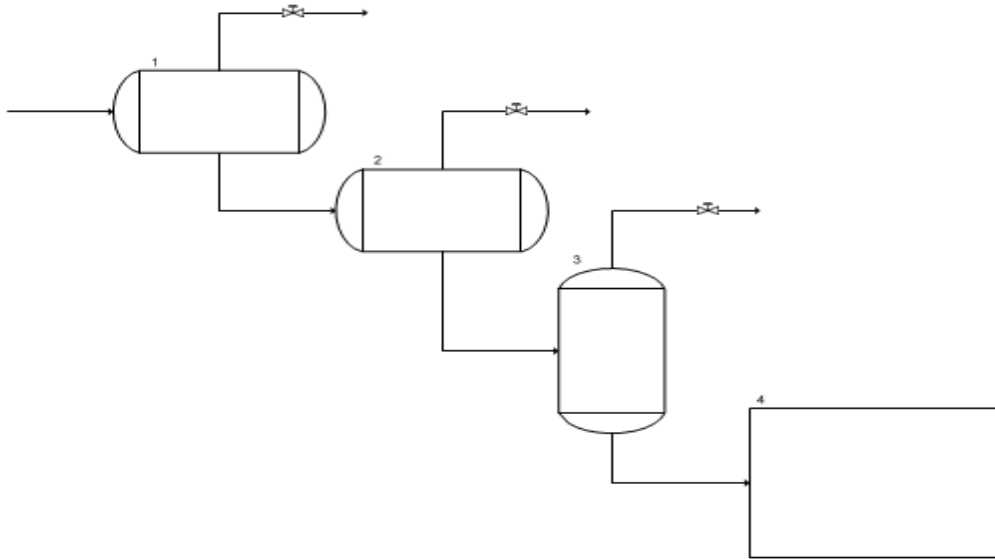

Fig. 2. Composition of equipment in multi-stage separation [5]

1. high pressure;
2. medium pressure;
3. low pressure separator;
4. tank.

Separator equipment

The purpose of installation is to increase the functionality of the separator and the efficiency of the separation process. The standard equipment of the separator is considered to be: input separator elements and coalescers, which are installed regardless of the shape of the separator or the number of phases that are separated.

The rest of the equipment is added as needed, most often in horizontal separators because they are more flexible in terms of available space and possible layout, and at the same time they are more susceptible to negative phenomena that occur during operation.

When choosing the equipment, the most attention should be paid to the characteristics of the mixture and the design of the separator, because in case of non-compliance, the opposite effect can occur, that is disruption of the separator [3].

Defoamers

The foaming of the surface layer of oil, except when the mixture enters the separator, also occurs when gas bubbles are released from the oil. This problem complicates the separation and automatic regulation of the process, and can be solved by adding chemicals at the inlet to the separator or, more simply, by mechanical defoamers. It is a series of parallel, obliquely placed longitudinal plates that cover the height to which the oil-gas boundary moves.

By passing the foamed mixture through the separator, there is contact between the formed foam bubbles and the plate, breaking the bubbles into droplets which then merge into the accumulation section of the separator [9].

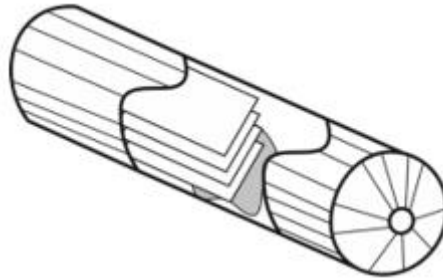

Fig. 3. Scheme of defoamers in the separator [1]

Barriers to neutralize the shock waves of the mixture

The formation of waves inside the separator can occur due to the pulsating inflow of the mixture or in the case when the separator is placed on the platform. Since this phenomenon negatively affects the separation process, it is necessary to install appropriate elements that will reduce their effect. This is especially true for long horizontal separators in which the action of waves is most pronounced. Barriers are placed vertically on the flow of liquid, so that they cover the accumulation section from the bottom to above the barrier or so that they cover only the profile of a certain height around the level of the barrier. The picture shows a full profile partition with perforations [8].



Fig. 4. Influence of barriers on liquid rolling and barrier appearance [1]

Vortex breakers

Vortices are the result of poorly designed drains from the separator, and they occur when the valve is opened and liquid is drained from the separator.

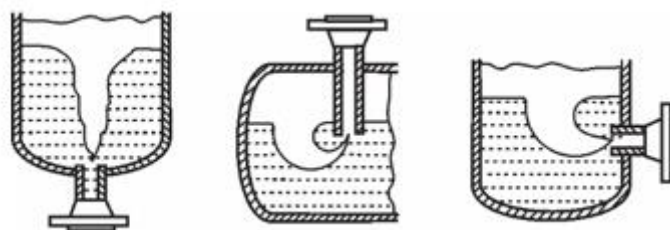

Fig. 5. Possible places of vortex formation in the separator [1]

Their formation in two-phase separators leads to the withdrawal of gas into the oil outlet line, which, in addition to the unwanted presence of gas in the outlet line, also leads to a large drop in pressure in the separator. In three-phase separators, the layer of oil and water also mixes, which in the end can mean the suction of oil into the outlet line during the discharge of water.

Prevention of vortex formation is achieved by installing the so-called. vortex breaker. These are various plate elements that are placed above the outlet or elements that are installed in the outlet pipe (Figure 6) [7].

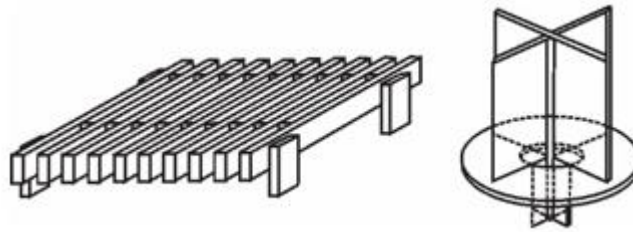

Fig. 6.Basic types of vortex "breakers" [1]

Coalescers and droplet catchers

The quality of separation is also reflected in the content of the liquid phase in the gas leaving the process. The lower that concentration, the more successful the process. Therefore, different elements are used to separate the droplets from the gas stream. The size of the droplets present in the gas phase depends on the method of formation, and their diameters can range from 0.1 to 5000 μm .

The smallest are those droplets that occur as a consequence of gas condensation (size from 0.1 to 5 μm). If the larger droplets are separated into smaller ones by mechanical action, for example when the mixture passes through a semi-open valve at high speeds, then their size can range from 10 to 200 μm . Finally, the largest droplets are formed during direct expulsion from the liquid due to the entry of fluid of uneven inflow, hitting the barriers and the like [2].



Fig. 7.Droplet catchers of various constructions [2]

Sand washing system

Accumulated sand can occupy a fairly large part of the separator after some time, which can lead to disruption of the separator. This problem is especially pronounced with horizontal separators, and an alternative to manual cleaning of the bottom can be the installation of a flushing system. The system consists of manifolds and nozzles arranged to cover the bottom of the separator.

For rinsing, water obtained from the process whose output speed from the nozzle (5 m / s) causes the movement of the sand layer towards the drainage openings through which the mixture of water and sand exits the separator is most often used. During the rinsing, the separation process does not need to be stopped. The system can act selectively, so that it rinses only the desired part or the entire separator, and with the appropriate equipment it can be fully automated. The figure shows the rinsing system and rinsing technique [2].



Fig. 8. Flushing system [2]

Horizontal separators

Horizontal separators are a very common choice in practice where they are mostly used as three-phase separators. Their construction results in the following advantages over other types of separators:

- the possibility of processing a large amount of mixture,
- possibility of processing the mixture subject to pulsating inflow and foaming,
- the possibility of processing the mixture with a medium and high proportion of the gas phase - due to the large contact area between the liquid and gas phases, and the large length are suitable for quality gas separation and
- for the same supplies, they are cheaper than upright separators (simpler construction).

The disadvantages of horizontal separators are:

- are not suitable for processing mixtures with a high proportion of solid particles.

After some time, the precipitated solid particles cover the bottom of the separator along its entire length, which makes their removal more difficult.

- the possibility of gas re-entering the liquid,
- require more storage space and are not suitable for installation in places such as platforms,
- uneven flow of the mixture into the separator can cause level control errors and even cause accidental interruption of the process, which is a problem in the automation of the separator [6].

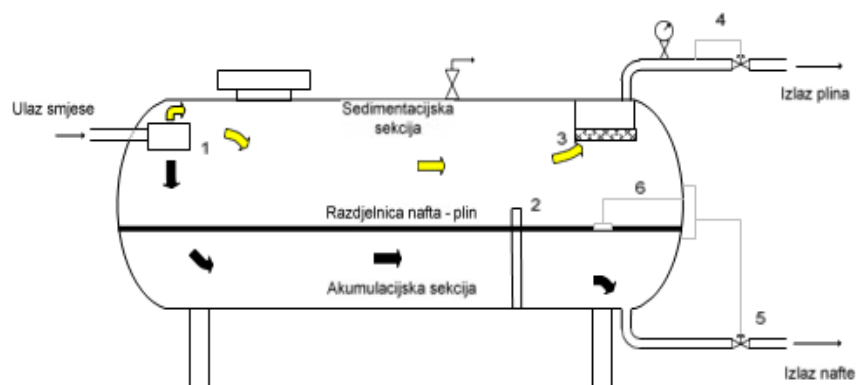

Fig. 9. Scheme of horizontal separator [6]

1. entrance partition;
2. partition;
3. droplet catcher;
4. pressure regulator and gas discharge valve;
5. oil drain valve;
6. level regulator (float).

Upright separators

In practice, in addition to horizontal, separators of upright construction can usually be seen. Upright separators are mainly used for processing a small amount of mixture with a small proportion of gas phase. They are a good choice if solid particles are present in the produced fluid, because the bottom of the separator is concave in shape, due to which the precipitate comes out of the separator together with the liquid or a separate drainage hole can be placed below the liquid outlet line. The probability of gas re-entry is small, because the phases after the initial separation have the opposite direction of movement. The height of the separator ensures easier and more reliable placement of control parts for automatic regulation, and due to the construction, they are mounted in places where space is limited [6].

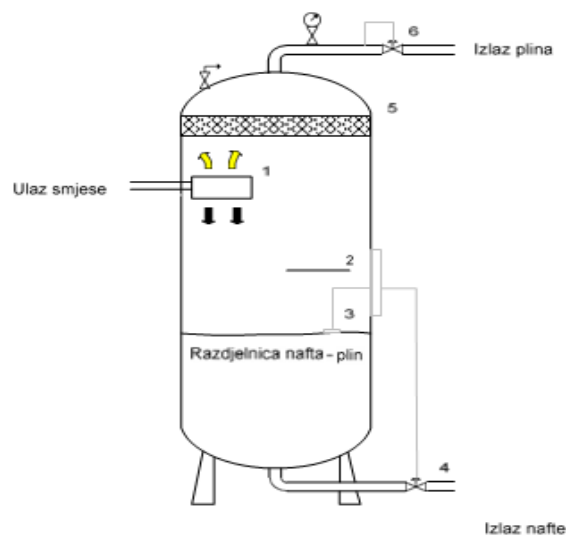

Fig. 10. Schematic of an upright two-phase separator [6]

RESULTS AND DISCUSSION

The first stage of separation

In two-phase separators, the liquid and gas phases are separated. The gas phase is discharged from two-phase separators into the drip tray (separator of a small amount of residual oil into gas), and the liquid phase (water / oil) with a small amount of the remaining gas phase into a three-phase separator.

Table 1. Characteristics of vertical separators [6]

Name of equipment	Operating parameters				Project parameters			
	Amount of fluid/oil Q, [m3/h]	Amount of gas Q, [m3/h]	Pressure p, [bar]	Temperature t, [oC]	Amount of fluid/oil Q, [m3/h]	Amount of gas Q, [m3/h]	Pressure p, [bar]	Temperature t, [oC]
Vertical two – phase measuring separator	6,79	21,65	2 – 4	55	52	4710,36	8,5	60
Vertical two – phase collective separator	6,79	21,65	2 – 4	40 – 50	52	4710,36	8,5	60
Gas dripper	-	43,3	2 – 4	10 – 40	52	4710,36	8,5	60

From the drip tray, the gas phase is directed to the boiler room, to the boiler, for the production of hot process water, and the excess is burned on a torch.

Table 2. Parameters of horizontal three-phase separator [6]

Name of equipment	Operating parameters				Project parameters			
	Amount of fluid/oil Q, [m3/h]	Amount of gas Q, [m3/h]	Pressure p, [bar]	Temperature t, [oC]	Amount of fluid/oil Q, [m3/h]	Amount of gas Q, [m3/h]	Pressure p, [bar]	Temperature t, [oC]
Horizontal three – phase separator	13,58	43,3	2 – 3	40 – 50	533,33	43570,83	4	60

When guiding the separator, it is necessary to maintain the level of the water phase at the highest possible value, in order to prolong the retention time in the separator. Extending the retention time of the aqueous emulsion and passing through the existing coalescing device in the second chamber of the separator, contributes to the desired reduction of the proportion of dispersed oil droplets in the aqueous emulsion, that is increasing the efficiency of the device.

CONCLUSION

Separators are steel vessels under a certain pressure. They can be located at a well, measuring or collection station where the acceptance and processing of hydrocarbon mixtures from nearby production wells is performed. Their main task is to separate the mixture into gas and liquid phase. The type of separator to be used depends first of all on the properties and quantity of the mixture, as well as the working pressure. In the process of selecting the separator, future changes in the properties of the produced fluid should be taken into account, in order to avoid problems in the operation of the separator and possible additional costs at a later stage of production.

REFERENCES

- [1] Arnold, K., Stewart, M., „Surface Production Operations: Design of Gas Handling Systems and Facilities“., Burlington., Elsevier., 1999.
- [2] American Petroleum Institute. „Specification for Oil and Gas Separators“., 12J (7 izd.). Washington, DC., API Publications and Distribution., 1999.

- [3] Gas Processors Suppliers Association., „Engineering Data Book“, Tulsa., Gas Processors Suppliers Association., 2004.
- [4] Muris, T.J., Parker, R.G., 2007. A Dozen Facts You Should Know About: Antitrust and the Oil Industry. Izvješće. Washington, D.C., SAD: US Chamber of Commerce.
- [5] Mičić, D., R., „Priprema i transport nafte“, Presentation 2., 2008.
- [6] Mičić, D, R., „Tehnika i tehnologija prerade nafte“, Industrijsko inženjerstvo u eksploataciji nafte i gasa“ Univerzitet u Novom Sadu., Tehnički fakultet „Mihajlo Pupin“, Zrenjanin., 2020.
- [7] Manning, F. S., & Thompson, R., „Oilfield Processing Volume Two: Crude Oil“, Tulsa., Pennwell Books., 1995.
- [8] Simon, K., „Sabiranje i transport nafte i plina I“, Priprema nafte za transport., Zagreb, 2010.
- [9] Zelić M., Petrović D., „Razvoj tehnologije proizvodnje, sabiranja i transporta nafte i plina“, Rudarsko-geološko naftni zbornik., Zagreb., 1990.

Session 5.

Health and Environmental Protection

CO₂ EMISSION ASSESSMENT OF CONSTRUCTION AND WASTE MATERIALS IN THE CONTEXT OF CIRCULAR ECONOMY: CASE STUDY OF PROJECT “CORRIDOR X”

Nikola Karanović¹

¹ University of Aveiro, CESAM – Centre for Environmental and Marine Studies,
Aveiro, Portugal

e-mail: nikolakaranovic@ua.pt

Abstract: Assessment of the environmental impact of construction materials and construction and demolition (C&D) waste is very important in the context of circular economy and sustainable development. This paper shows calculated CO₂ emissions using data on the quantities of used construction materials and the amount of generated construction and demolition waste (mostly inert material), using the IPCC 2013 method in the case of “Corridor X” project. “Corridor X” project represents one of the capital projects in Serbia and in the Balkan region. This analysis covers mainly road infrastructure. In this paper, data related to all construction activities, construction materials and construction and demolition waste are used. This analysis which is related to the assessment of the impact concerning all construction activities on the project “Corridor X” in the form of CO₂ emissions, thereby contributing with data and raising awareness of the principles of circular economy.

Key words: Environment, construction and demolition waste, circular economy

INTRODUCTION

It is estimated that around 374 million tons of construction and demolition (C&D) waste is generated annually in the European Union (EU) (excavated soil is not included), representing 31% of the total amount of waste generated [1]. No specific directive on this type of waste has been published within the European Union, only the Waste Framework Directive 2008/98/EU mentions measures that correlate with C&D waste. According to this directive, it is foreseen that by 2020, the reuse, recycling and revitalization of materials (including excavation operations) should be increased to the at least 70% by weight, not including excavation materials.

GENERAL ASPECTS OF C&D WASTE

Materials that remain on site immediately after the completion of construction or demolition of construction or infrastructure facilities, may be considered as C&D waste.

Such materials (C&D waste), are more difficult to process in terms of their reuse in construction, which is imposed, among other factors, by higher costs. Thus, for instance, waste material generated when removing the asphalt road could be used to build another asphalt road. The only requirement for C&D waste that will be reused in that case, is to ensure its inertness from an environmental point of view.

Recycling of C&D waste in the form of obtaining reusable materials includes the sorting of waste, which can be done during the construction or demolition of the construction infrastructure itself, and then the treatment of each of the components, according to the properties and potential applications of such materials. The recycling methods for each of the C&D waste materials are at the forefront of all the factors that are essential for the treatment of C&D waste, both from the point of view of their practical feasibility and from the point of view of their economic justification. Thus, for example, among the companies involved in the recycling of C&D waste, wood is the most commonly sought after construction material, primarily due to its potential for use as an energy source. For some other materials, such as metals and its alloys, there is already an elaborate global market for products derived from recycled materials. On the other hand, processed concrete has both a limited market and a limited scope [2].

Excavated materials as a potential resource

This material is formed during excavation processes in various construction activities and its composition can be extremely heterogeneous, with contents such as organic soil, loam, gravel, sand, old construction waste. Currently, the main purpose of this material is to cover the pits in the ground after excavation of sand, gravel or other construction materials. Excavated material that does not contain impurities that could actually or potentially contaminate soil or groundwater, can be used directly. This, in fact, contributes to the restoration of the site and the restoration of the environment to its original state. It is negligible that the excavated material used to cover the pits will ever be used again, but it is also considered that its use in soil revitalization and site restoration operations will close cycle of used construction material. The excavated material is almost always directly used, without the need for sorting.

CONSTRUCTION INDUSTRY AND THE ENVIRONMENT

The conventional construction sector is one of the largest consumers of raw materials. Globally, it is estimated that construction industry is consuming:

- 50% of all resources,
- 45% of energy for heating, cooling and lighting of buildings, and 5% during the construction,
- 40% of water for sanitary and other purposes,
- 60% of agricultural land,
- 70% of wooden products.

Many of the current construction materials used in the construction activities have been processed industrially (cement, steel, aluminum, sand, stone, clay, petroleum), which in many cases have negative effect to the environment and biodiversity.

Global annual carbon emissions as a result of construction activities reached its peak, at least temporarily, from around 9.5 gigatons of CO₂ (GtCO₂) in 2013, and then declined to 9 GtCO₂ in 2016. The energy intensity of the construction sector (in terms of energy consumption per m²) continues to improve at an annual rate of about 1.5%. The Paris agreement marked a milestone in the form of calls for curbing global warming. The rapid implementation of energy-efficient and low-carbon solutions in the construction sector can improve sustainability in the construction sector. The potential for energy savings and emissions in the construction sector remains largely untapped due to the continued use of less efficient technologies, with the lack of efficient policies and poor investment in sustainable infrastructure. Consumer choice and behavior also play a key role. However, energy-efficient, low-carbon products are already available in many markets [3].

AIM OF THIS WORK

The aim of this work is to show quantitative and comparative analysis of CO₂ emissions, consequently by using waste construction materials instead raw construction materials within the “Corridor X” project. In accordance with the principles of circular economy, one of the goals is to raise awareness of waste utilization (in the form of reuse or recycling) in order to reach the best possible solution that meets environmental aspects.

“CORRIDOR X” PROJECT

Corridor X is one of the most important Pan-European transport corridors that crosses Serbia and connects Austria, Hungary, Slovenia, Croatia, Serbia, Bulgaria, North Macedonia and Greece. With this project, the transport system of the Republic of Serbia becomes compatible with the transport system of the European Union, with a tendency for further modernization in order to enable the Republic of Serbia to comply with the European Union standards in the field of transport. The implementation of this important project will lead to a general acceleration of traffic, improve the level of service, facilitate international trade flows and transport of passengers. The new highway will have

a positive impact on commercial and trade activities in the region and will contribute to regional development and cohesion in the wider Balkans.

The “Corridor X” project is considered to be one of the capital projects in the Republic of Serbia. Corridor X includes the construction of 160 kilometers of highway south of Nis - Section E80 from Prosek to the Bulgarian border in Dimitrovgrad and E75 - from Grabovnica to Levosojce [4]. Assumption is that within the project “Corridor X”, some of the construction materials with the highest inflows are:

- Concrete,
- Steel,
- Asphalt.

METHODOLOGY

This research shows quantitative and comparative analysis of construction and waste materials within the “Corridor X” project and environmental impact in the form of CO₂ emissions. The data provided were used to calculate effects over a given time horizon resulting from the unit of mass emission related to the referent gas (GWP_{100a}), in this case the CO₂ emission was calculated using the IPCC 2013 method (Intergovernmental Panel on Climate Change). The functional unit in this case is 1 kg of construction materials and C&D waste. In this analysis, the *Ecoinvent 3.2* database was used to obtain benchmarks relating to the analyzed construction materials and C&D waste.

Life Cycle Assessment (LCA)

Life Cycle Assessment (LCA) is an analytical instrument that sets the framework for analyzing the environmental impact of products. ISO 14040 and 14044 provide the principles, frameworks, requirements and instructions for conducting the life cycle assessment of products and/or services. The main objective of impact assessment is to identify and establish links between the life cycle of products and services and the potential environmental impacts [5,6].

The LCA examines environmental aspects and potential environmental impacts (example, resource utilization and environmental effects of pollutant components) over the lifetime of raw material extraction products, through production, use and end-of-life treatment, recycling and dispose.

LCA as a tool can help with:

- Identifications and impacts within activities (example, greenhouse gas emissions),
- Ensuring all aspects of the environment throughout the life cycle (example, equal consideration of emissions into the air, water and land during the construction, operation and decommissioning of plants),
- Identifying opportunities to improve the economic and environmental performance of different technologies, projects, products and services,
- More effective communication with various stakeholders interested in information on the potential consequences of projects and technological options (example, LCA development process requires the involvement of different stakeholders, establishing communication and providing information on the full impact and/or benefits of certain changes or new production processes).

Also, the LCA can help with:

- Identifying opportunities to improve the environmental protection of products at different stages of their life cycle,
- Informing the various target groups that make decisions in industry, government and non-governmental organizations (example, for strategic planning, prioritization, design or project modification for products or processes),

- Selection of appropriate environmental performance indicators (indicators), including procedures for measuring pollution.

RESULTS

In this chapter, the results of the analysis of concrete, steel and asphalt in the form of CO₂ emissions using the IPCC 2013 method are presented. Table 1 presents the unit of emission and CO₂ emissions of concrete, steel and asphalt used.

Table1. Emission factors per unit for the analyzed materials and calculated kg CO₂ emissions related to the “Corridor X” project [7]

Material	Steel	Waste steel	Asphalt	Waste asphalt	Concrete	Waste concrete
IPPC 2013 (GWP 100a kg CO ₂ -eq)	2.346	0.0086	0.2897	0.02024	229.7	0.01329

According to the results from Table 1, it is visible that there is significant difference in the kg CO₂ between the product produced from raw materials and waste material.

Since steel, asphalt and concrete are in the most of it parts recyclable, following the principles of circular economy, Figures 1, 2 and 3 present environmental benefits by analyzing CO₂ emissions in the form of recycled construction materials as substitutes for construction materials obtained from primary production.

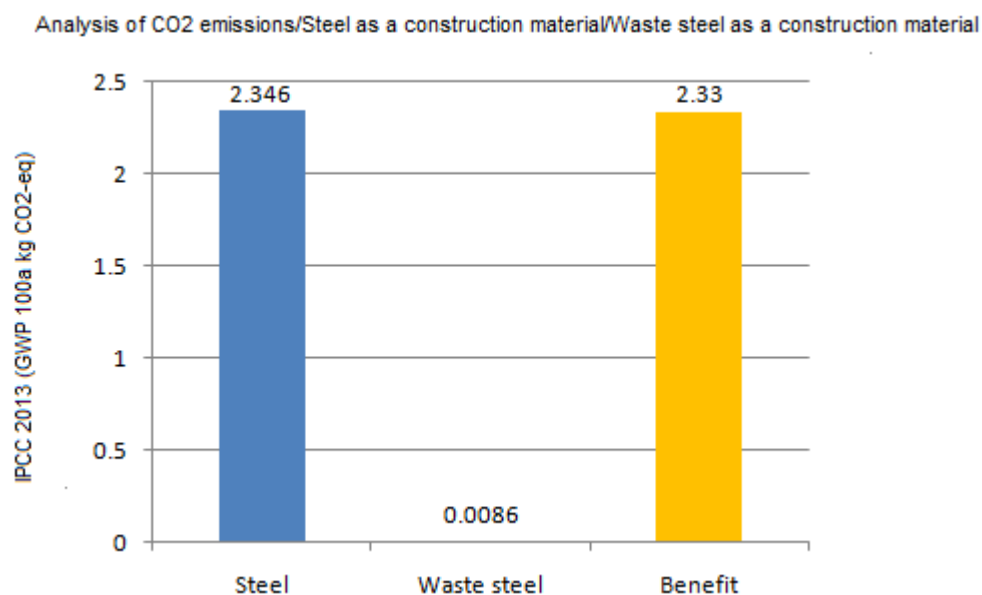

Fig. 1. Analysis of kg CO₂ emissions using steel as construction materials and using waste steel in the construction processes [4]

Fig. 1 shows the environmental benefit (orange color) as an example of using waste steel instead of steel produced by primary production (blue), which means that reduction in CO₂ emissions is 2.33 kg CO₂.

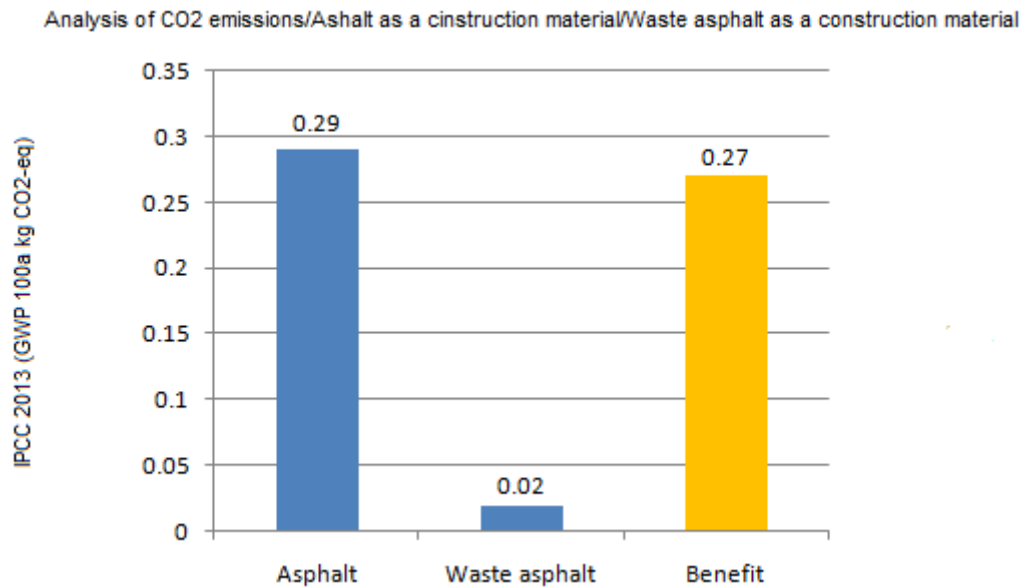

Fig. 2. Analysis of kg CO₂ emissions using asphalt as construction materials and using waste asphalt in the construction processes [4]

Fig. 2 shows the environmental benefit in the context of reducing kg CO₂ if waste asphalt was used in the project of “Corridor X” project instead of asphalt from primary production, resulting with 0.27 per kg CO₂ in reduction.



Fig. 3. Analysis of kg CO₂ emissions using concrete as construction materials and using waste concrete in the construction processes [4]

Fig. 3 shows an environmental benefit in the form of kg CO₂ reduction of waste concrete (aggregates). Concerning concrete, recycled concrete in the form of aggregates can be used in concrete production, although within concrete production itself, cement production industry is one of the largest environmental polluters. In this case, the analysis of kg CO₂ related to the concrete is presented empirically (assuming that the concrete obtained from primary production materials is completely replaced by recycled concrete). If recycled concrete (100%) is used on the “Corridor X” project, CO₂ emissions of CO₂ would be reduced by 229.68 kg.

CONCLUSION

This research considers quantitative and comparative analysis of construction and waste materials, from which it can be concluded that the use of recycled construction materials is an environmental benefit, both in terms of reducing CO₂ emissions and conserving the natural resources. In order to justify the benefits of EU waste legislation, a much deeper analysis of the environmental impact of C&D waste should be made. Considering the principles of circular economy, replacing raw materials from primary production with recycled ones, would be a more desirable option, as demonstrated in this analysis. In order to stimulate the use or recycling of C&D waste, there is a need for end markets. There is also a lack of information and data indicating flows and stocks of C&D waste in Serbia. This analysis is an initial step for further research related to construction materials and C&D waste within infrastructure projects.

REFERENCES

- [1] Eurostat, (2019a). “*Generation of waste by waste category, hazardousness and NACE*”, Rev. 2 activity [env_wasgen].
- [2] Karanovic N., (2008). “*Građevinski otpad*“, Master Thesis, Faculty of Technical Sciences, Novi Sad 2008.
- [3] UNEP, (2017). “*Towards a zero-emission, efficient, and resilient buildings and construction sector*”, Global Status Report, 2017.
- [4] Koridori Srbije, (accessed June, 2020). (<http://www.koridor10.rs/sr/koridor-10>).
- [5] ISO. (2006a). „*Environmental Management - Life Cycle Assessment-Principles and Framework*“, Second edition; ISO 14040; 2006-07-01; ISO: Geneva.
- [6] ISO. (2006b). „*Environmental Management-Life Cycle Assessment-Requirements and Guidelines*“, First edition: ISO 14044; 2006-07-01; ISO: Geneva.
- [7] Ecoinvent database 3.2, (accessed June, 2020). (<https://www.ecoinvent.org/database/database.html>).

ENVIRONMENTAL IMPACT ASSESSMENT FROM SMALL INCINERATION FACILITY OF ANIMAL CARCASS AND MATERIAL

Sandra Kozomora Subotin^{1*}, Dejan Ubavin¹, Bojan Batinić¹, Zoran Čepić¹

¹University of Novi Sad, Faculty of Technical Sciences, Novi Sad, Serbia

e-mail: kozomorasandra@gmail.com

Abstract: This work represents a review of environmental impact assessment from small incineration facilities of animal carcasses and material. The environmental impact assessment of the animal carcass incineration plant was done for a plant that was performed in real space and time. The principle of operation of the observed plant, as well as the equipment used for incineration, are explained. By observing the principles of operation, waste generated during the operation of the plant, and the implementation of pollution control, possible impacts on the environment have been assessed.

Key words: environmental impact, incineration, animal carcass

INTRODUCTION

Incineration has historically played a very important role as a method of disposing of corpses. Advances in science and technology, increasing public health awareness, growing environmental concerns, and evolving economic circumstances have influenced the use of incineration as a method of disposing of animal corpses. Today, there are three broad categories of combustion techniques: outdoor incineration, stationary incineration plant, and incineration by creating an air curtain.

Historically, the burning of corpses in a stationary plant has taken various forms, such as cremation, small incinerators for incineration, large incineration plants, incineration performed on farms, power plant incinerators, and incinerators that produce energy. During the 1970s, rising fuel prices reduced the popularity of such incinerators, but technological improvements in their efficiency soon emerged [1]. Since the outbreak of bovine spongiform encephalopathy (BSE) in the United Kingdom, stationary incinerators have been used to treat such infected tissue [2]. During the foot and mouth disease (FMD) epidemic in 2001, the sick animals were first sent to a rendering plant in the Netherlands, followed by the resulting meat and bone meal (MBM), as well as tallow which were all sent to a stationary plant [3]. In Japan, BSE-positive cattle are burned in incinerators.

Unlike outdoor ignition and air curtain incinerators, incineration in a stationary plant is completely meaningful and is usually highly controlled. Fixed-drive incinerators are usually filled with diesel, natural gas, or propane. Newer projections of stationary plants are equipped with secondary chambers to ensure complete combustion of hydrocarbon gases and particles (particulate matter - PM) which come out of the main combustion chamber [4].

The incinerator can be operated if it has the appropriate permit, which is generally defined by the legislation of each state. It is necessary to have properly trained operators working with the furnace. Small, stationary incinerators can also be used on farms, provided they have a permit, which also causes costs related to the legislation and maintenance of such a permit.

Many incinerators do not accept whole animals, noting that the corpses contain about 70% water [5]. Possibility of combining incineration with processing in a rendering plant, i.e., burning meat-and-bone meal and tallow after treatment in a rendering plant, would be potentially promising and should be explored.

MATERIAL AND METHODS

Description of the subject plant for incineration of animal carcasses and remains

The plant for incineration of animal carcasses and remains is a small incineration plant of 150 - 400 kg of animal waste per hour in model INCINER8 Model I8-250 (incinerator) shown in Fig. 1, depending on the type of animal material for incineration. Within the subject plant, reception (transport refrigerators), temporary storage (in the container-type refrigerator, which is shown in Fig. 2), and

incineration treatment are performed. The plant in question is an actual plant for the incineration of animal material.



Fig. 1. Incinerator INCINER8 Model I8-250, on the right side there is a sanitary and office container, and on the left side there is a refrigerator of container type.

Technical / technological equipment for incineration of animal waste in the subject facility consists of:

1. refrigerator,
2. sanitary container,
3. office container,
4. incinerator,
5. technical equipment,
6. fuel tank,
7. crane,
8. microbiological purifier.

The incinerator is designed in such a way that the waste is loaded directly into the incineration

chamber via the crane shown in Fig. 2, from the top. The materials used in the production are high-quality refractory insulation coatings that enable maximum heat retention, i.e., minimize heat losses. The incinerator has the ability to incinerate waste at high temperatures of over 1000 °C for greater efficiency and complete combustion. This model has a robust secondary chamber for complete combustion of smoke and pollutants in the emission from the combustion chamber at high temperatures.



Fig. 2. Cold store for temporary storage of animal corpses and remains with a crane that transfers animal material from the cold store to the incinerator.

The fuels used during the regular operation of the incinerator are biodiesel fuel, while the incinerator can also run on diesel fuel. During the 24-hour period, the incinerator is expected to consume approximately 500 L of diesel/biodiesel fuel, but only in the case of incineration of the maximum possible amount of waste for incineration, or 6000 kg of animal waste. However, when smaller amounts of animal waste are incinerated, about 250 L of diesel/biodiesel fuel is consumed on an average daily level.

The incinerator is designed so that the operator controls the combustion process by monitoring the temperature in the secondary and primary chambers, as well as the color and appearance of the smoke at the top of the chimney. In case of smoke, the operator, in accordance with the user instructions, adjusts the air level on the incinerator itself, to ensure optimal conditions for clean combustion of smoke and odors. The operator checks the amount of any remaining, unburned waste in the incinerator (residue from all batches during the working day), and programs a timer on the control panel so that all waste is incinerated without residue.

Table 1. Basic characteristics of the incinerator of animal waste INCINER8 Model I8-250 [6]

External Length	[mm]	3590
External Width	[mm]	1390
External Height	[mm]	4640
Shipping Weight	[kg]	8000
Combustion Chamber Volume	[m ³]	2.40
Operational Temperature	[°C]	850 - 1320
Gas Retention in Secondary Chamber	[sec.]	2
Temperature Monitoring	[-]	da
Average ash residue (%)	[%]	3
Thermostatic Device	[-]	da

After the incineration process, ash remains as a residue from the combustion of animal waste. Compared to outdoor combustion, ash cleaning is less problematic in stationary plants -- ash is usually considered safe and can be disposed of in landfills.

There are also certain amounts of wastewater that are discharged after each treatment process and directed through a drain to a microbiological treatment plant, which is a device for biological aerobic wastewater treatment, and the entire device is located in the ground. A disinfectant is used during the cleaning process. The disinfectant is a liquid agent with active chlorine with an extremely wide antimicrobial spectrum of action and a mild chlorine odor. It mixes easily with water. It acts quickly due to a wide range of biocidal activity. This type of biocidal product is used for disinfection and washing of equipment, packaging, accessories, and surfaces that come into contact with animal waste during handling, storage, and incineration. After use, rinse with water.

The microbiological wastewater treatment plant is a low-load, continuously flowing aeration system with pre-installed denitrification, i.e., a precipitator that also serves as a reservoir of excess sludge. The device is divided into a part for mechanical pre-treatment by which water influences the denitrification space, i.e., precipitator where sedimentation and separation of floating impurities occur and where in conditions of anoxidation organic matter decomposes with the simultaneous conversion of nitrate to nitrogen. The activated mixture is further directed to the aeration-nitrification space (activator), where further intensive process of decomposition of organic matter and oxidation of ammonia into nitrate takes place. The nitrification tank (activator) is equipped with a small bubble aeration system for intensive aeration, as well as a mammoth pump for internal recirculation re-denitrification (precipitator). From the aeration-nitrification tank, the mixture of wastewater and activated sludge gravitationally passes into the secondary precipitator, where the sedimentation of activated sludge occurs, and the purified water separates, which gravitationally flows out into the recipient. The secondary precipitator is also equipped with a system for removing floating sludge from the surface. The deposited activated sludge from the secondary precipitator is continuously returned to the activator and occasionally as excess sludge to the sludge tank. Stabilized sludge is cleaned once or twice a year.

RESULTS AND DISCUSSION

In order to be able to conduct an appropriate environmental impact assessment of the incinerator for incineration of animal carcasses and remains, it is necessary to consider the procedure in full, to establish its stages, mode of operation, and waste generated in the process. The methodology for determining the impact on the environment is based on the observation of the actual object and the activities that are carried out in it.

Pollution control

For the purpose of checking the emission of pollutants into the air, the concentrations of the following parameters were measured: CO, NO₂, SO₂, and powdery substances. It was established that the concentrations of the stated parameters were harmonized with the domestic legal regulations, i.e.,

adjusted to the medial half-hour value [7]. Many incinerators are equipped with secondary burners, which further reduce air pollution and combustion of smoke coming out of the primary combustion chamber [8]. Incinerator analyzed in this paper is equipped with a secondary burner that allows much lower concentrations of pollutants released into the atmosphere. A study was done, where two incinerators of animal corpses were selected in which the emission of Polycyclic Aromatic Hydrocarbons (PAHs) was measured [9], where it was concluded that there are certain concentrations of PAHs. Also, the content of heavy metals can be found in the exhaust gas [10]. Heavy metals collected in animal carcasses are not destroyed by combustion processes but are either collected in the ash in the lower parts of the incinerators, or air pollution control devices or emitted into the atmosphere [11]. Due to the possibility of burning at temperatures higher than 1000 °C, the incinerator enables efficient inactivation of pathogens [12], which is also the case with the observed incinerator. Wastewater treatment generated during the work process is performed with the help of a microbiological purifier that has been installed. The wastewater generated by the treatment must meet the quality requirements given by the competent authority, from which it is necessary to seek consent for water management within the company. Wastewater control needs to be done in accordance with the legal provisions.

Check of solid waste generated during the operation of the incinerator - ash. For ash, it is necessary to characterize the waste. Essential ash should be non-hazardous waste that can be disposed of in municipal landfills, but alternatively, it would be best to enable its use in some way, e.g., to improve soil quality.

Waste disposal management

At the subject location, municipal waste, ash, wastewater from a watertight pit, stabilized sludge from a microbiological purifier, rubber, packaging waste from cleaning agents are generated from waste materials.

Dehydration of stabilized sludge should be done in containers that are protected from leaks and atmospheric influences, after which, it is proposed to temporarily store it in a closed container. It is necessary to characterize the sludge and, depending on its properties, pass it on for further use/disposal to authorized operators. Stabilized sludge is cleaned once or twice a year.

Wastewater from a microbiological treatment plant needs to be brought to the quality of communal water so that it can be discharged into a watertight pit/city sewer.

Waste tires cannot be disposed of in a landfill. The owner of the waste tires should hand over the waste tires to the waste tire collector, and/or to the person who performs the storage of waste tires, i.e., to the person who performs the treatment of waste tires. The owner of waste tires, the collector of waste tires, the person who performs the transport of waste tires, the person who performs the storage of waste tires, and the person who performs the treatment of waste tires fill in the Document on waste movement, in accordance with a special regulation.

Packaging waste from cleaning agents needs to be temporarily stored in containers that are protected from leaks and atmospheric influences, especially from other types of waste generated in the company. Packaging waste must be handed over to an authorized operator in relation to the composition of the disinfectant used, i.e., its chemical properties.

Description of possible significant effects of the incineration plant on the environment

Air pollution

During the operation of the project, pollutants may be emitted into the air. The emission of pollutants into the air is done through the emitter of the ventilation system of the animal waste incineration plant, which is shown in Fig. 3. Insight into the factual situation on the ground, an inspection of the animal incinerator of the type "INCINER8 Model I8-250", which was installed, it was concluded that there is only one emitter that is in operation. The second emitter is used to transport the accumulated heat from the process of incineration of animal waste. During the incineration process, the generated waste gas passes through the secondary chamber (secondary incinerator - emission reduction device) where its additional incineration is performed, after which it is released into the atmosphere through the emitter.

Air pollution can also occur in the event of a fire, but also in the event of a refrigerator failure that would lead to the release of coolant into the atmosphere.



Fig. 3. Air emitters during combustion

Water and soil pollution

The operator is obliged to provide satisfactory characteristics of the wastewater generated in the facility, atmospheric water that reaches the site and to provide satisfactory characteristics of the land on the site. It is also necessary to ensure that the project in question does not affect the quality of land, as well as groundwater or surface water. The already described microbiological purifier is used for the treatment of wastewater generated in the process. Within the company, technological wastewater, sanitary-fecal wastewater, and polluted atmospheric water are generated. Technological wastewater and potentially polluted atmospheric waters are drained to a microbiological treatment plant, which should enable their quality to be at the level of municipal wastewater.

Noise

The noise that may occur does not have a negative impact on the environment, since noise emission occurs only during the arrival and departure of vehicles that bring/remove harmless animal waste, but this impact is occasional and discontinuous. Also, such a plant is built outside the populated area.

Ecosystem

The ecosystem can only be endangered in the event of an accident. Depending on the size of the accident, and the speed of reaction, the impact on the ecosystem will vary. Predicted accidents at the location are fire, breakdown during incinerator operation, refrigerant leakage from the cold storage, potential water contamination (fuel leakage during transfer to the furnace supply tank, wastewater spillage during failure of wastewater installations, microbiological treatment plant, etc.), and potential soil contamination (fuel leakage during transfer to the furnace supply tank, inadequate disposal of waste generated during plant operation, problems during reloading of treatment materials, etc.).

CONCLUSION

Based on the above facts, it is concluded that small plants for the incineration of animal corpses and remains have the greatest negative impact on the environment when it comes to air pollution. Great care must be taken to reduce emissions of pollutants into the atmosphere by applying appropriate furnace design methods and/or by installing purifiers. Also, during the operation of the plant, wastewater is generated when hygienic and sanitary procedures are conducted in the facility, and such wastewater must be treated with an appropriate wastewater treatment plant since they contain potentially infectious substances. For safety and continuous monitoring of air and water emission parameters, it is proposed to continuously measure pollutants from emitters into the air and from treated wastewater after a microbiological treatment plant.

Special attention should be direct to the adequate management of waste generated in the company, and to ensure that there is no negative impact on the environment when it comes to waste management.

A very favorable impact of incineration plants is that they provide really high biosafety of treated animal material while having a negative impact on the economic aspect, i.e. they are quite expensive to handle and maintain, and use fuels that can also have a negative impact to the environment.

In addition to all the above, the incineration process in the plant is one of the most suitable methods of disposing of animal corpses and remains, considering all its effects on the environment, especially if it is a small plant that performs on-site incineration.

REFERENCES

- [1] Wineland, M.J., Carter, T.A., Anderson, K.E.. Incineration or composting: cost comparison of the methods. *Poultry Digest*, Vol. 56, No. 6, pp. 22-27, 1997.
- [2] Herbert, D. Five million carcasses and counting. Retrieved 13 August, 2003, <http://edition.cnn.com/2001/WORLD/europe/01/23/britain.cow/>, 2001.
- [3] de Klerk, P.F.. Carcass disposal: lessons from the Netherlands after the foot and mouth disease outbreak of 2001, *Revue scientifique et technique Office international des Épizooties*, Vol. 21 No. 3, pp. 789-796, 2002.
- [4] Rosenhaft, M.E.. An evaluation of requirements for pathological incineration facilities, *Laboratory animal science*, Vol. 24, No.6, pp. 905-909, 1974.
- [5] Thacker, H.L.. Carcass Disposal: A Comprehensive Review, Chapter 6: Alkalinehydrolysis. National Agricultural Biosecurity Center Consortium, USDA, 2004.
- [6] INCINER8 Limited 2018 Company, <https://www.inciner8.com/animal-incinerator/I8-250A>
- [7] Regulation of the types of waste for which thermal treatment is performed, conditions and criteria for determining the location, technical and technological conditions for the design, construction, equipment and operation of thermal waste treatment plants, treatment of the residue after incineration (in Serbian) (Sl. glasnik RS, br. 102/2010 i 50/2012).
- [8] Nutsch, A., Spire, M.. Carcass Disposal: A Comprehensive Review, Chapter 1. Burial. National Agricultural Biosecurity Center Consortium, USDA, 2004.
- [9] Chen, S.J., Hsieh, L.T., Chiu, S.C.. Emission of polycyclic aromatic hydrocarbons from animal carcass incinerators. *The Science of the Total Environment*, Vol. 313, pp. 61–76, 2003a.
- [10] Chen, S.J., Hung, M.C., Huang, K.L., Hwang, W.I.. Emission of heavy metals from animal carcass incinerators in Taiwan, *Chemosphere*, Vol. 55, pp. 1197–1205, 2003b.
- [11] Sullivan, R., Woods, I. Using emission factors to characterize heavy metal emissions from sewage sludge incinerators in Australia, *Atmos. Environ.*, 2000. Vol. 34, pp. 4571–4577, 2000.
- [12] Willis, N.D.. Animal carcas disposal. Past President of the OIE International Committee Ottawa, Canada, Ontario, 2003.

FIRE RISKS IN A SMALL INCINERATION FACILITY OF ANIMAL CARCASS AND MATERIAL

Sandra Kozomora Subotin¹, Dejan Ubavin¹, Jelena Radonić¹, Zoran Čepić¹

¹University of Novi Sad, Faculty of Technical Sciences, Novi Sad, Serbia

e- mail: kozomorasandra@gmail.com

Abstract: This work represents a review of fire risks in a small incineration facility of animal carcass and material. The mode of operation of real existence for the incineration of animal corpses and materials, which is of small capacity, is presented in this piece. In accordance with the method of operation, method of construction and method of design of the incineration plant, the risks of fire in relation to the presence of flammable materials and substances were taken into consideration. Also, human activities that can lead to fires in a small plant for burning animal corpses and materials were considered. The risk analysis is given in order to avoid potential fires during the operation of a real plant for incineration of animal corpses and remains.

Key words: fire protect, animal carcass, incineration

INTRODUCTION

Fires that can occur in a plant for the incineration of animal carcasses and remains represent a significant environmental and economic challenge, as well as a challenge for the community and the environment itself. Causes of fires that can occur in the incineration plant are human activity, the process of self-ignition in biomass during improper storage, the presence of flammable substances, technical error in the plant, electrical error or faulty electrical installations, the presence of embers in burnt material, specific characteristics of animal carcasses that can cause explosion.

It is very important to perform the correct design of the system, to provide during the construction of the plant appropriate materials, appropriate safety distances of fire protection equipment, to determine the necessary means and equipment for fire protection, it is necessary to provide efficient evacuation, all in accordance with the legislation of the competent authority. Furthermore, it is necessary to think about the previously mentioned facts during the planning of the plant, then during the construction, and special measures must be implemented during the operation of the plant and maintenance. Lastly, it is of key importance for the stated tasks of fire protection to anticipate possible sources of fire, depending on the process and materials that will be used in the process of incineration of animal corpses and remains.

Waste treatment and recovery activities, for example in France, rank third in the ranking of activities with the most accidents according to the data from the Incident Database of Analysis, Research and Information on Accidents (ARIA) [1]. Waste management activities in France (classified as NAF code 38) lead to a significant number of accidents accounting for 11% of all accidents in the period 2005-2014 years according to ARIA data [1]. When it comes to serious accidents, the waste management sector is on the 12th place, while it is on the 3rd place by the number of total accidents [1]. The most common hazards in the waste management sector are fire and discharge of hazardous and / or pollutants [2]. Fires are present in 80% of all accidents that occur when it comes to waste management, while 45% of fires are combined with the release of pollutants and hazardous substances [2]. Fires rarely appear as an accident, especially when it comes to waste management, where they can very easily be combined with explosions, other emergencies such as earthquakes, plant accidents, environmental pollution and the like. The release of pollutants during a fire is especially related to the smoke that develops during a fire and which contains dangerous and polluting substances. Fig. 1 shows the hazard phenomena when it comes to waste management.

Hazardous phenomenon	Percentage of accidents by phenomenon ³	
	Waste sector	All environmentally sensitive facilities
Fire	78%	62%
Discharge of hazardous/polluting substances	47%	49%
Explosion	6%	8%
Other phenomena ⁴	12%	8%

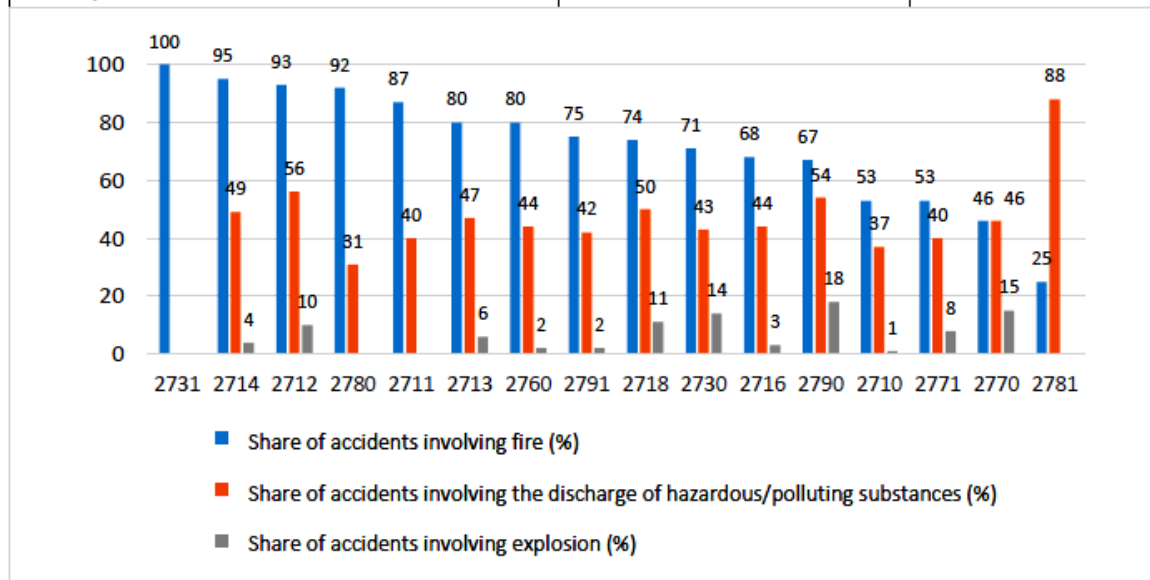

2731	Storage of animal by-products	2718	Handling/consolidation/sorting of hazardous waste
2714	Handling/consolidation/sorting of paper, plastics	2730	Treatment of animal by-products
2712	Automobile scrapyards	2716	Handling/consolidation/sorting of non-hazardous waste
2780	Composting	2790	Treatment of hazardous waste
2711	Handling/consolidation/sorting of WEEE	2710	Dump sites
2713	Handling/consolidation/sorting of metals	2771	Incineration of non-hazardous waste
2760	Landfill	2770	Incineration of hazardous waste
2791	Treatment of non-hazardous waste	2781	Methanisation

Fig. 1. Presentation of accidents in waste management [2]

Data processed in France in the period 2005-2014 years show that fire is the most common pattern of accidents during the incineration and treatment of animal by-products, especially when it comes to the storage of animal by-products, as shown in Fig. 1. Therefore, special care is required for the implementation of fire protection measures when it comes to the incineration of animal corpses, careful planning, management and maintenance of the plant. It is desirable to avoid potential causes of fire.

MATERIAL AND METHODS

Description of the subject plant for incineration of animal carcasses and remains

The subject plant that is analysed in the paper is based on the actual plant for incineration of animal waste. The incineration facility occupies an area of 144 m², and is constructed as a ground floor facility - canopy. The dimensions of the canopy construction are 10 m x 12 m. The construction of the canopy consisting of pillars and the roof grille are made of steel profiles. The dimensions of the pillars are 160 x 160 x 4 mm. In the middle of the canopy, a steel beam is provided on which a crane up to

one ton is mounted. Steel corneas are placed over the roof grilles, to which a trapezoidal sheet is attached. The foundation is made over foundation feet measuring 100 x 80 cm. The floor AB slab is 20 cm thick. The dimensions of the floor concrete slab are 12 x 12 m. The canopy is intended to cover equipment for incineration of animal waste.

The equipment of the incineration process consists of:

1. Container-refrigerator: A refrigerator is a device in which harmless animal waste is disposed of before it is disposed of in an incinerator. The refrigerator is of the container type. The refrigerator has overall dimensions of 8 x 3 x 2 m, $Q = 10.5 \text{ kW}$, $t = + 2^\circ\text{C}$ and has two doors and is used for regular operation, the refrigerant is freon R-404A in the amount of 8.6 kg;
2. Sanitary container;
3. Office container;
4. Incinerator: INCINER8 Model I8-250 incinerator has a chamber capacity of 2.40 m^3 , which is designed to incinerate from 150 - 400 kg of non-hazardous animal waste per hour. The materials used in the production of incinerator are high-quality refractory insulation coatings that enable maximum heat retention, which allows for minimization heat losses;
5. Command cabinet;
6. Fuel tank (biodiesel / diesel) to supply the incinerator, capacity up to 2000 l;
7. The microbiological treatment plant within the working unit is a device for biological aerobic wastewater treatment. Capacity 6-10 ES (for 6.10 permanently connected population equivalent or ES). The device model is AQ AS VARIOCOMP 8. The purifier cleans 1.2 m^3 of water per day. The purifier is a container-compact type of round shape with dimensions $\Phi 1280 \text{ mm} \times 2020 \text{ mm}$ with an inlet shaft and a total volume of 2 m^3 . The whole device is in the ground;
8. Crane with a capacity of up to one ton.

All process equipment is located under the steel canopy except the fuel tank and the microbiological purifier as shown in Fig. 2.

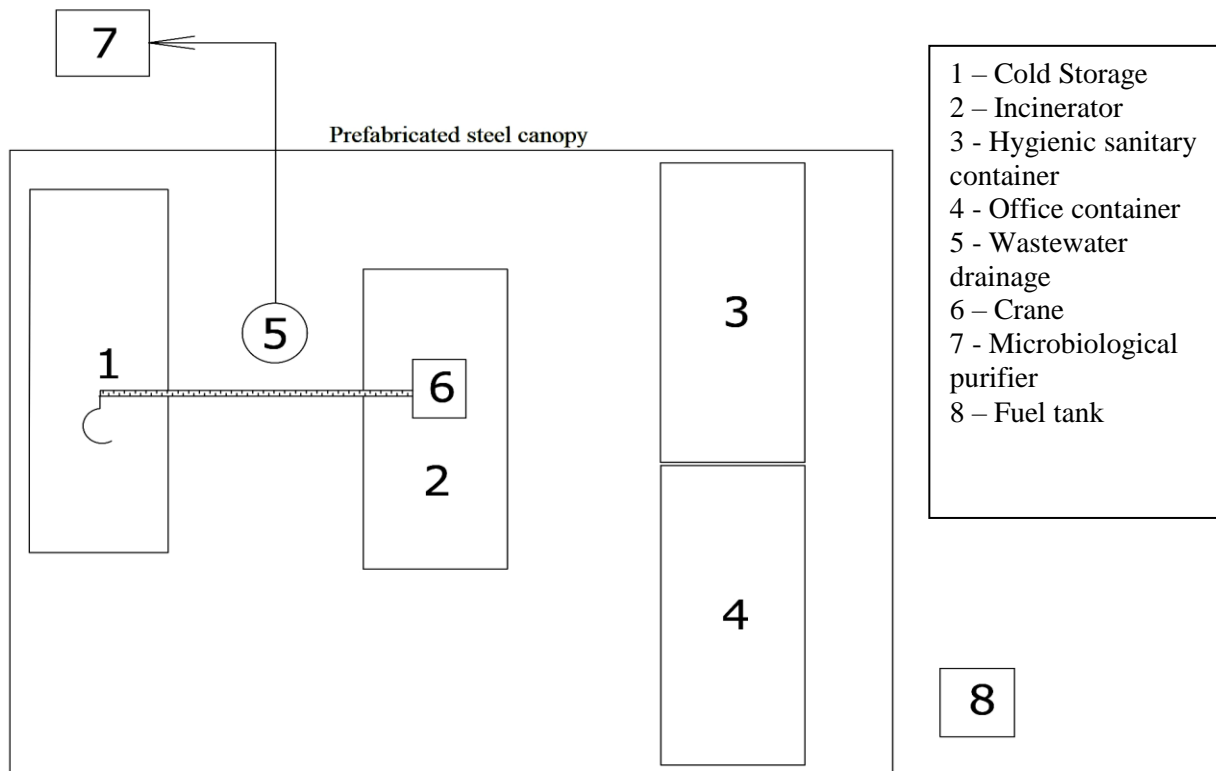

Fig. 2. Technological scheme of equipment for incineration of animal carcass

Technological processes during the operation of the observed plant for incineration of animal carcass

1. Starting the device - the incinerator is cleaned of ash generated in the previous incineration process, visually inspected to make sure that all burners and sensors are functioning properly.
2. Disposal of ash - ash resulting from the incineration of animal waste is temporarily disposed of in bags, then in containers.
3. Raising the temperature of the secondary chamber - pressing the button on the control panel of the incinerator initiates the process of raising the temperature. A secondary burner is used to raise the temperature, or if necessary all burners on the device. The final temperature is usually 950°C - 1320°C.
4. Waste collection - waste acceptance is done on the unloading ramp. The operator transfers the waste to the refrigerator with a hand forklift, where it is stored at a temperature of 0 – 4°C until incineration.
5. Loading of waste into the incinerator - after all conditions are met (the previous batch is completed, the temperature of the secondary chamber is at the prescribed level), the waste is transferred from the refrigerator directly to the incinerator.
6. Starting the incineration process - after all the conditions are met (waste is loaded into the incinerator, the firebox door is closed, the temperature is at the prescribed level), selecting the command on the control panel starts the incineration process.
7. Combustion process - the operator controls the combustion process by monitoring the temperature in the secondary and primary chambers, and the color and appearance of the smoke at the top of the chimney. In the event of smoke, the operator adjusts the amount of air in the incinerator in accordance with the instructions to ensure optimal conditions for clean combustion without smoke and odors.
8. Completion of the batch - the operator records the drop in process temperature and the time elapsed since the loading of waste, and concludes that the batch is completed. Before loading the next batch, the operator extinguishes the burners on the primary chamber by selecting a command on the control panel.
9. Residue incineration - the operator checks the amount of any remaining, unburned waste in the incinerator (residue from all batches in the day), and programs a timer on the control panel to incinerate all that waste without residue.
10. Incinerator cooling - after the programmed time from the previous step expires, the incinerator automatically enters the cooling phase. The cooling process is completely automatic, controlled by a time timer and takes place without the supervision of the operator. The process takes 6 hours, after which the incinerator shuts itself off.
11. Cleaning and disinfection is carried out in accordance with veterinary and sanitary regulations, the operator cleans and disinfects all areas in contact with waste as well as disinfects all tools and equipment used in the process, as well as protective equipment of the operator. Wastewater generated in the process of cleaning and disinfection is conducted through sewage channels into a microbiological treatment plant together with wastewater from the sanitary facility.
12. Writing records - the operator records the amount of animal waste incinerated in one day, as well as any remaining amount of waste in the cooling chamber (refrigerator).

Fig. 3 and 4 show the observed plant for incineration of animal carcasses and materials.



Fig. 3 and 4 Steel canopy with equipment for incineration of animal by-products, carcasses and materials

RESULTS AND DISCUSSION

Fire hazard analysis

In order to be able to implement appropriate fire and explosion protection measures for the facility and installations in the facility, it is necessary to know the physical - chemical properties of the materials used in the work process and of which the facility and work equipment are made. Also, it is very important to look at the work process itself and determine the critical points for the outbreak of fire. Therefore, the basic characteristics of the material will be listed, with special emphasis on the physical - chemical characteristics that are most important from the point of view of fire and explosion protection. The methodology for determining risky materials and activities is based on the observation of the actual object and the activities carried out in it.

The following substances and characteristics of substances and processes from the aspect of fire protection appear in the facility for burning animal corpses and remains:

- Paper (Cardboard). It belongs to the group of solid flammable substances. Paper is a substance of organic origin, and the basic raw material for its production is cellulose. The degree of

flammability of the paper and the course of combustion depend on the type and shape in which it is located. The paper ignites easily in the presence of an open flame, and heated to a temperature of about 450 °C ignites on its own. The paper is primarily in an office container.

- Wood. It belongs to the group of solid flammable substances. Wood burning is done in several stages. Ignition occurs at a temperature of 250 - 300 °C, and the self-ignition point is 350 - 400 °C. Wood materials are in the form of furniture in the office and sanitary container.
- Plastics. They belong to the group of solid flammable substances, which are high-molecular organic compounds made on the basis of resin, with the addition of fillers, plasticizers, stabilizers, catalysts and paints. The properties of plastics are conditioned primarily by their structure, composition, and depend on the type of resin that plastic products contain as a binder. Plastics soften already at 100 °C, begin to decompose at 150 °C, and during combustion a large amount of thick opaque smoke is created, which in most cases is poisonous. A refrigerator, an office and a sanitary container were made of plastic.
- Biodiesel. Biodiesel is a liquid fuel produced from vegetable oils or from used oils and fats. Flash point approx. 150 °C. Biodiesel is a fuel for the incinerator located in an underground tank with a volume of up to 2000 m³.

During the operation of the animal waste incineration plant, the most significant waste generated from the aspect of the possibility of fire is:

- Ash. During the operation of the incinerator, ash remains as a result of the incineration of animal waste. The ash is temporarily stored in bags or containers. Ash can be a potential source of fire if it does not burn completely and embers remain.
- Municipal waste (paper, office supplies) that will occur in small quantities, due to daily activities in the office.
- Tires from transport vehicles (mini truck with a refrigerator for the transport of non-hazardous animal waste) belong to the group of solid fuels. Rubber is a vulcanized rubber, and in addition to rubber, it contains sulfur and other additives. The tire is difficult to ignite, but when ignited it burns quite intensely.
- Stabilized sludge from a microbiological purifier. Dehydration of stabilized sludge should be performed in containers that are protected from leaks and atmospheric influences, and after that it is necessary to temporarily store it in a closed container. The possibilities of sludge ignition depend on the expected physical and chemical properties of the sludge, its nutritional values, heat capacity and energy potential.
- Packaging waste from cleaning agents Packaging waste from cleaning agents is temporarily stored in containers that are protected from leaks and atmospheric influences, especially from other types of waste that are generated. Disinfectants are flammable liquids and can be a source of fire.

Possible sources of fire

Refrigerator as a source of fire: the most common cause of fire when it comes to the refrigerator may be inadequate design of the refrigerator and its performance or electrical failure. Most of the fires caused by the refrigerator were due to the presence of an electrical fault or electrical reasons, so it is very important to analyze traces and other evidence that can be associated with electrical failure in the refrigerator to determine the cause of the fire and prevent possible fires caused by the refrigerator [3].

The transfer of biodiesel from the tank to the underground tank is a critical activity from the aspect of fire protection. Streaming as an activity must be carried out under the control of the responsible person. Fig. 5 shows the position of the underground tank.



Fig. 5 The position of the underground tank and place of the fuel overflow.

Improper storage of animal carcasses and remains: Animal carcasses and remains must be stored in a refrigerator to reduce the risk of fire outbreaks, due to flammable gases resulting from their decomposition. There is usually a high density of material that needs to be treated at material storage sites. Warehouses are very vulnerable points from the aspect of fire outbreaks in relation to other structures [4].

Presence of methane in the stomach of ruminant carcasses: Methane (CH_4) is a gas that affects the greenhouse effect and has a 32 times greater effect of global warming than CO_2 [5]. A very important part of ruminant energy metabolism is methane genesis, i.e. methane is released during ruminants [6]. Due to its properties, methane remains in the stomach of ruminant corpses. Therefore, it is necessary to take special care because methane is a highly flammable gas and in case it is not released from the stomach of ruminants before being inserted into the incinerator, it can cause an explosion.

Explosion of an animal's carcass: The most well-known cases are the posthumous explosions of whales, which can be the cause of the natural decay of the corpse or the inappropriate disposal of the corpse [7]. There are other cases of animal explosions that are defensive in nature or caused by human activity. Corpse explosions, such as whale explosions, are caused by the formation of methane by bacteria inside the corpse during the decomposition process [8]. Also, the origin of the corpses of animals must be known and it is necessary to establish whether there is a possibility that there are any weapons in the corpses. In China, oxen carrying large explosives were used to be used as self-propelled explosive missiles [9]. There are also a large number of documented cases where animals were used to deliver weapons, mostly bombs, which were carried by donkeys, mules and horses [10]. Therefore, it is necessary to carry out adequate checks on animal carcasses before storing and treating them for incineration.

Electrical failure or malfunction of the plant for incineration of animal carcasses and remains, caused by failure of electrical installations or failure of the plant itself in terms of technical error, or as a result of inadequate maintenance can also be a source of fire.

Human activity: Fire risk and fire outbreak can also occur with inadequate handling and maintenance of the incinerator, violation of the smoking ban, inadequate and irregular maintenance of fire protection equipment, failure to implement preventive fire protection measures and other similar situations caused by human activity.

CONCLUSION

Based on all the above in the paper, we can conclude that in the plant for the incineration of animal carcasses and materials may appear fires of solid, liquid and gaseous substance, as well as fires in electrical installations. The aim of this paper is to analyze fire risks and materials that can cause fire in order to set up an adequate system for fire protection and prevention.

An adequate fire protection system must be implemented in accordance with the legislation of the competent authorities at the location of the plant for the incineration of animal corpses and remains. In accordance with the analyzed data, it is possible to determine: the need for equipment and devices for extinguishing, fire detection and alarm, organization of plant operation and storage of process material in such a way as to prevent fires, evacuation methods, fire sectors, actions in case of fire, as well as the way to act after a fire.

REFERENCES

- [1] ARIA - Analysis, Research and Information on Accidents, Available at <http://www.aria.developpement-durable.gouv.fr/find-accident/?lang=en>
- [2] Ministry of the environment, energy and the sea of France, Overview of accident statistics on waste management facilities- October 2016 -, Available at <https://www.aria.developpement-durable.gouv.fr/wp-content/uploads/2017/06/2016-10-11-SY-AccidentologieDechetsVersionSimplifiee-PA-EN-Vfin.pdf> .
- [3] Yang, W.B., Ling, S.Y., Mo, S.J., Liang, D., Wang, Y., Research of Trace Analysis and Investigation Method for Refrigerator-caused Fire, *Procedia Engineering*, Vol. 52., pp. 526 – 531, 2013.
- [4] Ding, L., Khan, F., Ji, J., Risk-based safety measure allocation to prevent and mitigate storage fire hazards, *Process Safety and Environmental Protection*, Vol.135., pp. 282 – 293, 2020.
- [5] Holmes, C. D., Prather, M. J., Søvde, O. A., Myhre, G., Future methane, hydroxyl, and their uncertainties: Key climate and emission parameters for future predictions, *Atmos. Chem. Phys.*, Vol. 13., pp. 285–302, 2013.
- [6] Hill, J., McSweeney, C., Wright, A.G., Bishop-Hurley, G., Kalantar-Zadeh, K., Measuring Methane Production from Ruminants, *Trends in Biotechnology*, Vol. 34, No. 1, pp. 26-35, 2016.
- [7] Hackstadt, S., The Evidence, Available at <http://theexplodingwhale.com/>
- [8] eTaiwan News, Sperm whale explodes in Taiwanese City, Available at <http://news.bbc.co.uk/2/hi/science/nature/3437455.stm> .
- [9] Turnbull, S., *Siege Weapons of the Far East: AD 300–1300*, Osprey Publishing, p. 40., 2001.
- [10] PETA, Leave the Animals in Peace: PETA's letter to Yasser Arafat Archived 2009-11-28 at the Wayback Machine February 3, 2003.

EPOXICONAZOLE AND TEBUCONAZOLE ADSORPTION IN TWENTY DIFFERENT AGRICULTURAL SOILS IN RELATION TO THEIR PROPERTIES

Nikola Bošković¹, Kerstin Brandstätter-Scherr², Petr Sedláček³,
Zuzana Bílková¹, Lucie Bielská², Jakub Hofman¹

¹Research Centre for Toxic Compounds in the Environment (RECETOX), Faculty of Science, Masaryk University, Kamenice 753/5, Brno, 625 00, Czech Republic

²Institute for Environmental Biotechnology, Department for Agrobiotechnology (IFA-Tulln), University of Natural Resources and Life Sciences (BOKU), Konrad-Lorenz-Strasse 20, A-3430 Tulln, Austria

³Materials Research Centre, Brno University of Technology, Purkyňova 464/118, 612 00, Brno, Czech Republic

e-mail: nikola.boskovic@recetox.muni.cz

Abstract: Conazole fungicides are currently used pesticides with considerable chronic toxicity and ecotoxicity that are also on EU list for substitution. They enter the soil forming short- or long-term residues. In this study two of their representatives, epoxiconazole (EPC) and tebuconazole (TBC), have been tested with 20 soils from the Czech Republic for their adsorption. Adsorption, by means of K_d coefficients, was compared to basic soil properties like total organic carbon (TOC), $pH_{(H_2O)}$, clay, clay + fine silt, fine silt, silt, fine sand, sand, cation exchange capacity (CEC). Some correlations were revealed between EPC and TBC adsorption and soil organic matter parameters. Recalculating K_d to K_{oc} and to Gibb's free energy (ΔG) and its values indicated that the adsorption of EPC and TBC is mainly weak physical adsorption – partitioning. Also, ΔG values gave better correlation with $pH_{(H_2O)}$ than K_d . The number and types of H-bonds with molecular geometry govern the sorption, which might crucially affect leachability in soil, and this may indicate that TBC is more leachable than EPC for the same soil.

Key words: Soil property, Conazole fungicides, Adsorption, Distribution coefficient

INTRODUCTION

Epoxiconazole (EPC) and tebuconazole (TBC) are triazoles, part of conazole fungicides (CFs) which are used every year increasingly in agricultural practices. EPC is a broad-spectrum fungicide for control of diseases caused by *Ascomycetes*, *Basidiomycetes* and *Deuteromycetes* and TBC is effective against various smut and bunt diseases in cereals and other field crops [1]. Major use of all CFs in Central Europe is on cereals and oil plants [2, 3]. In the Czech Republic, EPC and TBC are commonly used for cereals (winter wheat, spring and winter barley), maize, beat, potatoes, oil plants (rape), poppy, hops, fruits (apples), and grapes [2]. In plant protection products, they are most often formulated as emulsifiable concentrate, emulsion oil in water, suspension concentrate, suspo-emulsion and they are often combined with fungicides of other classes (strobilurins, pyrazoles, morpholines, benzimidazoles) or there are multiple conazoles combined in one product [2, 3]. They are typically applied at doses between 80–340 g/ha, as foliar sprays on crops being in 25–70 BBCH growth phase and about 1–2 months before crop harvest [2, 3]. EPC and TBC are currently used pesticides and they belong to those having “risky” properties: very high bioaccumulation potential with $\log K_{ow} > 3$, strong adsorption in soil with $K_{oc} > 500$, and long persistency with $DT_{50} > 30$ [4]. Combining their properties with increased levels of usage explains the long-term residues of EPC and TBC found in soils of Europe [5-7]. EPC and TBC had a median content of 0.02 mg/kg, with maximum values ranging from 0.16 to 0.31 mg/kg in Europe [8]. EPC and TBC also frequently exceeded the 0.01 mg/kg limit (in 25% and 11% of soils, respectively) [5]. The mean concentrations usually were in units of $\mu\text{g}/\text{kg}$ and maxima in tens of $\mu\text{g}/\text{kg}$ [5]. The highest concentration was found in the UKZUZ survey for TBC and was 0.140 mg/kg (unpublished data).

The fate and bioavailability of EPC and TBC in soils has not often been studied. Few experimental studies have reported TBC adsorption in soils and the effect of pH on it [9, 10]. EPC is slightly to moderately adsorbed to soil with low leaching potential [11] and TBC exhibits high to low mobility in

soil [12]. Additionally, it was concluded that TBC adsorption was unlikely pH-dependent [12]. Due to its pKa about 5, this means that at a soil of pH 5 it is 50% dissociated, i.e. in protonated form which binds more effectively to soil clays and organic matter with negatively charged functional groups [9], [10]. In order to more closely examine the fate and behavior of EPC and TBC in the soil environment, pesticide adsorption can be presented by the soil-water distribution coefficient (K_d). Typically, lab and field DT50 values which range from 60 to 365 days can be considered as highly persistent in soil with a tendency to form long-term residues which can have even more negative effects on organisms [4]. These are the reasons why conazole fungicides are among EU candidates for substitution [13] on the basis of the persistent, bioaccumulative and toxic criteria, highlighting the potential for endocrine disruption and toxicity for reproduction.

This study aims to reveal more information about the adsorption of two conazole fungicides (EPC and TBC) in 20 arable soils from the Czech Republic and to find its relationship with basic (TOC, pH, clay, clay + fine silt, fine silt, silt, fine sand, sand, CEC) properties.

MATERIALS AND METHODS

Soils

Soils from 20 farmland locations in the Czech Republic were used in this study. Collecting was done from 0–15 cm of surface layer after removing grass and other remains. After air-drying the soil was sieved through a 2 mm mesh.

Basic physicochemical properties were determined using standardized methods. The total organic carbon content (TOC) was analysed on a LECO RC612 multi-element analyser as CO_2 evolving between 100 and 540 °C measured via an infrared detector [14]. Soil pH in H_2O suspensions was measured according to ISO 10390 [15]. The contents of the following particles of various sizes were determined by the sedimentation method according to ISO 11277: clay (< 0.001 mm), clay + fine silt (< 0.01 mm), fine silt (0.001–0.01 mm), silt (0.01–0.05 mm), fine sand (0.05–0.25 mm), and sand (0.25–2 mm) [14]. Cation exchange capacity (CEC) was determined according to ISO 23470 [16].

Chemicals

Epoxiconazole (EPC) and tebuconazole (TBC), PESTANAL® analytical standards (Sigma-Aldrich, CR) were used for preparing 1 mg/ml solutions of both compounds separately in acetonitrile (AcN; Merck, CR). To get the aqueous stock solution for the experiments, 0.3 ml of the 1 mg/ml solution was added to 100 ml of 0.01 M $\text{CaCl}_2/\text{NaN}_3$ solution (in Milli-Q water) and sonicated for 30 min. The final theoretical concentration of the pesticide in this solution is 3 µg/ml and the concentration of AcN is 0.3%. The solutions were kept at 4 °C before experiments or analyses.

Adsorption equilibrium experiments

For two soils (6 and 20) selected as representatives of high and mid TOC (%), full sorption isotherms were measured to judge if the full isotherms are necessary for the whole set of 20 soils. Based on the results showing almost linear isotherms we decided to measure the sorption of the other 18 soils only at two concentrations 50 and 500 ng/ml.

The procedure of adsorption was always the same. Firstly 2 g of dry soil were placed into a glass tube (Kimble® KIMAX® 50 mL round bottom centrifuge tube; Kimble® Kontes, USA), and secondly 20 ml of solution of 0.01 M $\text{CaCl}_2/\text{NaN}_3$ was added and shaken (100 rpm). After equilibration of soil chemistry for 48 h, an appropriate volume of pesticide solution (3 µg/ml, see above) was added and remaining 0.01 M $\text{CaCl}_2/\text{NaN}_3$ solution was added to get total 35 ml of solution in the system. In the case of the desired 500 and 50 ng/ml, the pesticide solution was added in 5.83 ml and 0.58 ml to the tubes and completed by 9.17 and 14.42 ml, respectively, of the 0.01 M $\text{CaCl}_2/\text{NaN}_3$. The ratio 1:17.5 (soil:solution) resulted in mass sorption of 23–61% for EPC and 15–62% for TBC in all performed experiments. In general practice it is useful to settle on a few fixed ratios, for which the percentage adsorbed is above 20% [17].

For both concentrations, also control tubes were running which contained no soil, only solutions. Also, blank tubes were running which contained only soil and 0.01 M CaCl₂/NaN₃ free of pesticides. All variants were run in four replicates. The tubes were shaken at 100 rpm. After reaching an equilibrium of pesticide distribution between water and soil (48 h), the tubes were centrifuged at 3,000 rpm for 90 min. The supernatant was carefully taken for LC-MS/MS analysis. The concentrations in soils were not measured but calculated using loss of pesticide from the solution shaken with soil compared to the same solution shaken without soil.

Conazole fungicide quantification by LC-MS/MS

An Agilent 1200 chromatographic system (Agilent, Santa Clara, CA, USA) equipped with a vacuum degasser, binary pump, autosampler and column thermostat was connected online to a ESI/QqQ mass spectrometer Agilent Triple Quad 6410 (Agilent, Santa Clara, CA, USA). The chromatographic/mass spectrometric system was controlled by Mass Hunter software. An analytical column ACE 3 C18, 150 mm x 2.1 mm i. d., 3 μm particle size with integrated guard column ACE 3 C18 (2.1 mm x 10 mm, 3 μm particle size), (ACE, Scotland, UK) were used for analytical separation. The column temperature was set to 30 °C. A mobile phase consisted of 0.1% formic acid in water (solvent A) and 0.1% formic acid in acetonitrile (solvent B). The mobile phase gradient was as follows: 0–1 min 10% B, 1–7 min from 10% B to 98% B, held at 98% B to 12 min, 12–13 min from 98% B to 10% B, with a subsequent equilibration step of 10% B to 25 min. The flow rate was 0.3 ml/min; 5 μl of sample and 5 μl of a mix of internal standard (d-metolachlor, d-tebuconazole) were injected. The parameters of the ion source were set as follows: gas temperature 350 °C, gas flow 9 l/min, nebuliser gas 40 psi, capillary voltage 4000 V. The instrument was operated in the ESI-positive mode.

Calculations

Quantifying adsorbed fungicide in equilibrium was obtained by calculating with equations 1–4:

$$C_s = \frac{(C_0 - C_e) * V}{m} \quad (1)$$

where C_s is the concentration of adsorbed fungicide in soil (ng/g_{dw}), C_e is the equilibrium concentration of fungicide in water (ng/ml), V is the volume of solution in the tube (ml; i.e. 35 ml), m is soil mass (g_{dw}; i.e. 2 g_{dw}).

The soil-water distribution coefficient (K_d ; ml/g_{dw}) was used for characterizing adsorption on soil:

$$K_d = \frac{C_s}{C_e} \quad (2)$$

K_d describes the amount of compounds adsorbed onto soil per amount of water, which can vary significantly since the total organic content (TOC) is not considered in the equation. A more realistic and convenient way to express adsorption is with the partition coefficient onto soil organic matter (K_{oc}).

$$K_{oc} = \frac{(K_d * 100)}{TOC (\%)} \quad (3)$$

The adsorption process of the compound to the surface consisting of organic matter can be expressed by the change of Gibb's free energy (ΔG , kJ/mol) [18] in the equation:

$$\Delta G = -RT \ln K_{oc} \quad (4)$$

where R is the gas constant (8.31 J/K mol), and T is the Kelvin temperature (298 K). The absolute ΔG value shows the extent to which the adsorption reaction may take place [19].

All data were analyzed by means of Excel 2016 (Microsoft, USA) with Real Statistics AddIn and GraphPad Prism 5 (GraphPad Software, Inc., USA). Pearson, Spearman correlation were carried out on the data to reveal the relationships between soil properties and the adsorption data. This was done by correlating data of basic physicochemical properties with K_d values.

RESULTS AND DISCUSSION

The adsorption of neutral compounds has been extensively investigated and appears to depend on soil organic matter content. The molecular nature of soil organic matter has been proved to be key in determining the adsorption of nonionic pesticides [20, 21]. It is now well accepted that organic matter and clay minerals are the principal soil constituents involved in pesticide adsorption [22, 23]. A number of soil properties including its chemistry, mineralogy, soil organic matter, pH and environmental factors such as soil water content and temperature can influence pesticide adsorption in soil as well [24].

In our study, the EPC and TBC adsorption in soil was determined according to OECD guideline [17]. Before the testing the adsorption in 20 soils, the preliminary experiments were performed to determine equilibrium time and appropriate soil/solution ratio. The results clearly showed that 48 h are enough to reach equilibrium for the distribution of pesticides between soil and solution. Also, the ratio of soil/solution of 1:17.5 was confirmed. Then, the K_d values were obtained from different soils and correlated with the governing adsorption factors. The selected soils covered a relatively wide spectrum of basic properties having a TOC range (0.54–3.91%), $pH_{(H_2O)}$ (5.15–7.98%), clay (3.7–41.5%), clay + fine silt (8.7–71.6%), fine silt (3.4–41.9%), silt (8.7–71.6%), fine sand (4.1–49%), sand (0.5–50.6%) and CEC (26–437 meq/kg).

EPC and TBC adsorption in soils

In this study, equilibrium adsorption data, soil water distribution coefficient (K_d) were obtained for 20 different soils. Adsorption reflects strength or intensity, which is the energy distribution of the adsorption site [25].

The adsorption of two pesticides were measured on 20 soils at 2 concentrations and recalculated to K_d for both concentrations. Fig. 1 shows the values ranging from 5.37 and 3.55 to 24.84 and 25.99 ml/g for EPC and TBC respectively. When the K_d values measured at 50 ng/ml and 500 ng/ml were compared, they were found to be significantly different (t-test, $p < 0.05$) in 13 out of 20 cases. Thus, the original data were not pooled and two values (K_d for an initial aqueous concentration of 50 and 500 ng/ml) are considered separately. Definitely the lower value (considering the corresponding soil concentration) is closer to field concentrations (these are max in the tens of ng/g, see e.g.[5]).

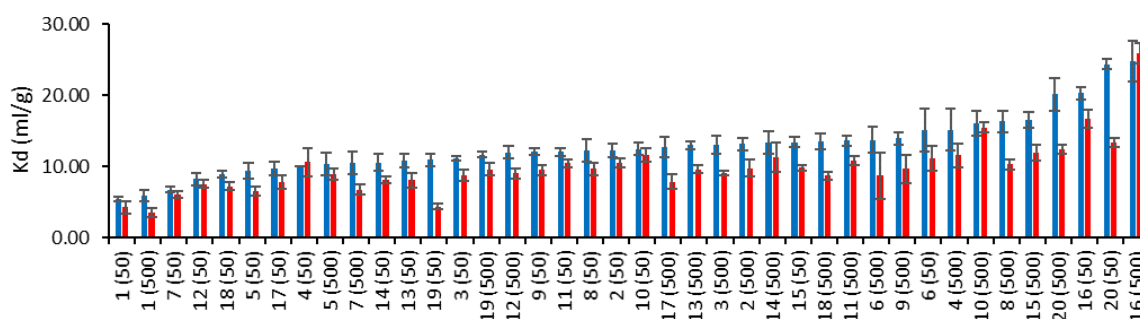

Fig. 1. EPC (blue) and TBC (red) K_d values (ml/g) in 2 (50 and 500 ng/ml) equilibrium solution

In the soil set there were soils with extremely high (soil 20) and extremely low (soil 1) contents of TOC (within the typical ranges of arable land in Czech Republic [26]). They also showed the highest (24.4, 13.3, 20.2, 12.4 ml/g) and the lowest K_d of both compounds (5.4, 4.2, 5.9, 3.6 ml/g for K_d EPC

50, Kd TEB 50, Kd EPC 500, Kd TEB 500, respectively). These ranges are similar with ranges of Kd values in this study. TBC Kd values were determined in three soils (silty loam and two sandy loam soils) and they were 1.78, 3.04, 7.77 ml/g respectively [27]. Kd values varied from 7.7 to 16.4 ml/g (sandy loam soil) for TBC with the higher clay content exhibiting stronger adsorption [28]. Previous research have shown a similar Kd value (the average in sandy loam soils was 12.4 ml/g) [29]. Researched TBC adsorption on soils which are similar with soils from this study in terms of soil sampling location, but the Kd values were not determined in the previously mentioned works [9, 10]. European Food Safety Authority (EFSA) reports [11, 30] can be updated with Kd values from this study which can show EPC and TBC distribution between Czech soil and pore water. Soil adsorption studies for EPC showed 280–2647 ml/g K_{oc} values [11] and for TBC the determined K_{oc} values ranged from 128.4 to 1249 ml/g [30]. In this study the K_{oc} values were 344.70–1521.61 ml/g for EPC and 158.86–1226.30 ml/g for TBC.

Relationships of adsorption with soil properties

Using the Pearsons (P) correlation, the TOC showed a positive relationship with EPC ($r = 0.58$, $p < 0.0001$) and TBC ($r = 0.32$, $p < 0.05$). This was unexpected, because previous studies showed that there is no dependency on the organic carbon content for EPC [11]. On the contrary, the Spearman (S) correlation showed no significant relationship with EPC and TBC ($r = 0.29$, and $r = 0.18$, $p > 0.05$). These findings are counter to the [11] results for EPC, but for TBC there may be supporting [12] findings.

EPC was found to correlate significantly and negatively to pH (see **Error! Reference source not found.**) and for TBC was found to correlate more significantly (see **Error! Reference source not found.**) with pH values. Nevertheless, K_{oc} had good reason to be calculated from all Kd values and TOC (%). Firstly, it is the standard for expressing the soil adsorption of organic pollutants, and secondly, it allows one to correlate adsorption with other properties, independently of TOC. Using K_{oc} values for finding the relationship with pH values suggests also a significant correlation for EPC and TBC (**Error! Reference source not found.**).

Furthermore, recalculating all K_{oc} values to ΔG gives better statistical correlation with pH compared with Kd values, because it is the masking effect of TOC which was removed by recalculation. This conversion gives a positive correlation for EPC ($r_p = 0.29$, $r_s = 0.26$) and TBC (**Error! Reference source not found.**). Almost all p-values were < 0.0001 . Unexpectedly clay, clay + fine silt, fine silt, silt, fine sand, sand, CEC had insignificant statistical results in this case study ($p > 0.05$)(see **Error! Reference source not found.**). An analysis of these correlations showed that $pH_{(H_2O)}$ was an important driver for EPC and TBC retention in soils.

Table 1. Pearson and Spearman correlation with p-values

vs	Fungicide	Pearson (P)	p-value	Spearman (S)	p-value	P/S
Kd/pH	EPC	-0.44	0.005	-0.42	0.01	1.05
	TBC	-0.63	<0.0001	-0.65	<0.0001	0.97
K_{oc}/pH	EPC	-0.26	0.0003	-0.26	0.0003	1.01
	TBC	-0.31	<0.0001	-0.24	0.0009	1.31
ΔG/pH	EPC	0.29	<0.0001	0.26	0.0003	1.10
	TBC	0.37	<0.0001	0.32	<0.0001	1.17
Kd/TOC	EPC	0.58	<0.0001	0.29	0.07	1.99
	TBC	0.32	0.04	0.18	0.26	1.77
Kd/Clay	EPC	0.41	0.01	0.26	0.11	1.62
	TBC	0.18	0.26	0.23	0.15	0.80
Kd/Clay + fine silt	EPC	0.30	0.06	0.12	0.47	2.54
	TBC	0.14	0.40	0.08	0.62	1.71
Kd/Fine silt	EPC	0.08	0.63	-0.06	0.72	-1.37

	TBC	0.04	0.79	-0.11	0.52	-0.41
Kd/Silt	EPC	0.30	0.06	0.12	0.47	2.54
	TBC	0.14	0.40	0.08	0.62	1.71
Kd/Fine sand	EPC	-0.21	0.19	-0.21	0.19	0.99
	TBC	-0.11	0.48	-0.13	0.41	0.85
Kd/Sand	EPC	-0.07	0.65	0.08	0.60	-0.88
	TBC	-0.06	0.73	0.01	0.94	-4.33
Kd/CEC	EPC	0.30	0.06	0.10	0.53	2.91
	TBC	-0.03	0.88	-0.05	0.77	0.54

CONCLUSIONS

In this study, adsorption (K_d values) of epoxiconazole (EPC) and tebuconazole (TBC) were measured for 20 different agricultural soils from the Czech Republic. It can be concluded that there was a broad range of adsorption soils from low to high TOC (%).

From among the basic soil properties, $pH_{(H_2O)}$ values played a substantial role for adsorption strength. Recalculation of K_d values to K_{oc} and afterwards to ΔG gives a significant statistical correlation with $pH_{(H_2O)}$. EPC adsorption was more influenced and sorbed more strongly with pH changes compared to TBC.

This study confirmed and updated EPC and TBC soil adsorption factors in a broader view which may be beneficial or inspirational for decision makers. It also helped to better understand adsorption of conazole fungicides in soil from freely dissolved form which may be empirically linked with bioaccumulative property causing risk of toxicity, like endocrine disruption and toxicity for reproduction, in pesticide contaminated soils highlighting them for substitution in the future.

ACKNOWLEDGMENTS

This research was supported by a project of the Czech Science Foundation (GF17-33820L) and Austrian Science Fund (FWF): I 3133, by the RECETOX research infrastructure (the Czech Ministry of Education, Youth and Sports: LM2018121) and the CETOCOEN EXCELLENCE Teaming 2 project supported by Horizon2020 (857560) the Czech Ministry of Education, Youth and Sports (02.1.01/0.0/0.0/18_046/0015975) and Austrian Science Fund (FWF): I 3133.

REFERENCES

- [1] Bozdogan, A.M.: Assessment of total risk on non-target organisms in fungicide application for agricultural sustainability, *Sustain.*, No 6, pp.1046-1058, 2014.
- [2] Ústřední kontrolní a zkušební ústav zemědělský: Czech Republic - Usage of active substances in 2017, http://eagri.cz/public/web/file/587988/celek_2017_EN.pdf.
- [3] Agromanual: www.agromanual.cz, <https://www.agromanual.cz/cz/casopis-agromanual/agromanual-2020-0>
- [4] University of Hertfordshire PPDB: Pesticide Properties DataBase, <http://sitem.herts.ac.uk/aeru/ppdb/en/index.htm>.
- [5] Hvězdová, M., Kosubová P., Košíková M.: Currently and recently used pesticides in Central European arable soils, *Sci Total Environ.*, No 613-614, pp. 361-370, 2018.
- [6] Székács, A., Mörtl, M., Darvas, B.: Monitoring pesticide residues in surface and ground water in Hungary: Surveys in 1990-2015., *J Chem.*, 2015.
- [7] Vidal, J.L.M., Sánchez, J.A.P., Plaza-Bolaños, P., Frenich, A.G., Romero-González, R.: Use of pressurized liquid extraction for the simultaneous analysis of 28 polar and 94 non-polar pesticides in agricultural soils by GC/QqQ-MS/MS and UPLC/QqQ-MS/MS, *J AOAC Int.*, No93, pp. 1715-1731, 2010.

- [8] Silva, V., Mol, H.G.J., Zomer, P., Tienstra, M., Ritsema, C.J., Geissen, V.: Pesticide residues in European agricultural soils – A hidden reality unfolded., *Sci Total Environ.*, No653, pp. 1532-1545, 2019.
- [9] Čadková, E., Komárek, M., Kaliszová, R., Koudelková, V., Dvořák, J., Vaněk, A.: Sorption of tebuconazole onto selected soil minerals and humic acids., *J Environ Sci Heal - Part B Pestic Food Contam Agric Wastes.*, No47, pp. 336-342, 2012.
- [10] Čadková, E., Komárek, M., Kaliszová, R., Vaněk, A., Balíková, M.: Tebuconazole Sorption in Contrasting Soil Types. *Soil Sediment Contam.*, No22, pp. 404-414, 2013.
- [11] European Food Safety Authority: Conclusion regarding the peer review of the pesticide risk assessment of the active substance epoxiconazole, *European Food Safety Authority J.*, No6, pp. 1-80, 2008.
- [12] European Food Safety Authority: Conclusion on the peer review of the pesticide risk assessment of the active substance tebuconazole, *European Food Safety Authority J.*, No12, pp. 1-98, 2008.
- [13] European Commission: List of Candidates for Substitution. http://ec.europa.eu/food/plant/pesticides/approval_active_substances/index_en.htm.
- [14] Scherr, K.E., Bielská, L., Kosubová, P.: Occurrence of Chlorotriazine herbicides and their transformation products in arable soils, *Environ Pollut.*, No222, pp. 283-293, 2017.
- [15] ISO 10390: Soil quality – Determination of pH, <https://www.iso.org/obp/ui/#iso:std:iso:24415:-1:ed-1:v1:en>.
- [16] ISO 23470: Soil quality — Determination of effective cation exchange capacity (CEC) and exchangeable cations using a hexamminecobalt(III)chloride solution, <https://www.iso.org/standard/68765.html>.
- [17] OECD. Guidelines for Testing of Chemicals, Section 1 (106): Adsorption-Desorption Using Batch Equilibrium Method, Environment Directorate, Paris, France, https://archive.epa.gov/scipoly/sap/meetings/web/pdf/106_adsorption_desorption_using.pdf.
- [18] Maznah, Z., Halimah, M., Ismail, S.: Adsorption-desorption behavior of thiram: effect of soil type, temperature and pH, *Chil J Agric Res.*, No76, pp. 371-377, 2016.
- [19] Armanpour, S., Bing, L.: Adsorption of Herbicide Butachlor in Cultivated Soils of Golestan Province, *J Geosci Environ Prot.*, No3, pp. 15-24, 2015.
- [20] Farha, W., Abd, El-Aty, A.M., Rahman, M.M., Shin, H.C., Shim, J.H.: An overview on common aspects influencing the dissipation pattern of pesticides: a review, *Environ Monit Assess*, No188, 2016.
- [21] Yong, R.N., Mulligan, C.N.: *Natural and Enhanced Attenuation of Contaminants in Soils*. 2nd ed. Boca Raton, Florida, USA, 2019.
- [22] Monkiedje, A., Spiteller, M.: Sorptive behavior of the phenylamide fungicides, mefenoxam and metalaxyl, and their acid metabolite in typical Cameroonian and German soils, *Chemosphere*, No49, pp. 659-668, 2002.
- [23] Hiller, E., Khun, M., Zemanová, L., Jurkovič, L., Bartal, M.: Laboratory study of retention and release of weak acid herbicide MCPA by soils and sediments and leaching potential of MCPA, *Soil Environ.*, No52, pp. 550-558, 2006.
- [24] Kookana, R.S., Ahmad, R., Farenhorst, A.: Sorption of pesticides and its dependence on soil properties: Chemometrics approach for estimating sorption, *ACS Symp Ser.*, No1174, pp. 221-240, 2014.
- [25] Liu, Y., Xu, Z., Wu, X., Gui, W., Zhu, G.: Adsorption and desorption behavior of herbicide diuron on various Chinese cultivated soils, *J Hazard Mater*, No178, pp. 462-468, 2010.

- [26] Polakova, S., Kubik, L., Praskova, L., Maly, S., Nemecek, P., Stana, J.: Monitoring of Agricultural Soils in the Czech Republic 1992–2013, 2017.
- [27] Kumar, L.S., Arya, S., Singh, S.B.: Adsorption-Desorption of Tebuconazole in Three Soils, Pesticide Research Journal, No29, pp. 82-87, 2017.
- [28] Komárek, M., Čadková, E., Chrástný, V., Bordas, F., Bollinger, J.C.: Contamination of vineyard soils with fungicides: A review of environmental and toxicological aspects, Environ Int., No36, pp. 138-151, 2010.
- [29] Bending, G.D., Rodríguez-Cruz, M.S., Lincoln, S.D.: Fungicide impacts on microbial communities in soils with contrasting management histories, Chemosphere, No69, pp. 82-88, 2007.
- [30] European Food Safety Authority: Conclusion regarding the peer review of the pesticide risk assessment of the active substance tebuconazole, European Food Safety Authority J., No12, pp. 98, 2008.

EMISSION OF GREENHOUSE GASES FROM “BUBANJ” LANDFILL IN NIŠ

Jasmina Radosavljević¹, Amelija Đorđević¹, Ana Vukadinović¹, Lidija Milošević¹

¹University of Niš, Faculty of Occupational Safety in Niš, Niš, Serbia

e-mail: jasmina.radosavljevic@znrfaq.ni.ac.rs, amelija.djordjevic@znrfaq.ni.ac.rs,
ana.vukadinovic@znrfaq.ni.ac.rs, lidija.milosevic@znrfaq.ni.ac.rs

Abstract: Deposited waste in a landfill decomposes in four phases: aerobic, anaerobic non-methanogenic, anaerobic unstable methanogenic, and anaerobic stable methanogenic phase. The decomposition produces the landfill gas, which is usually composed of methane (CH₄) and carbon dioxide (CO₂), with traces of volatile organic compounds (VOC). Methane and carbon dioxide in the landfill gas contribute to higher atmospheric concentrations of this gas, which directly increases the greenhouse effect and the temperature in the air layers closer to earth's surface, eventually affecting global climate change. This paper presents the methane and carbon dioxide concentrations measured at “Bubanj” landfill in Niš, Serbia.

Key words: landfills, landfill gases, methane, carbon dioxide

INTRODUCTION

Landfill gas is predominantly composed of methane (CH₄) and carbon dioxide (CO₂) with traces of volatile organic compounds (VOC). It is estimated that methane emissions from municipal waste landfills constitute 3-19% of the total global anthropogenic sources of methane [1]. The gas produced in landfills is formed through decomposition of organic matter by the bacteria present in the landfill and in the earth used to cover the landfill during the day. The components of deposited waste that include significant amounts of biodegradable matter include food, garden waste, textile, paper, cardboard, etc. The deposited waste decomposes in four phases and the composition of produced gas changes during each phase [2]. Methane and carbon dioxide are the main constituents of landfill gas. The ratio of the two gases depends on the composition of municipal waste and the decomposition process and is usually around 55:45%. In addition to methane and carbon dioxide, other gases are also emitted during waste decomposition, including hydrogen, ammonia, nitrogen, oxygen, hydrogen sulphide, mercaptans, ethane, propane, butane, argon, etc. The formation of landfill gas depends on the morphological composition of waste, oxygen and moisture content, landfill body temperature, and the time the deposited waste spends in the landfill [3, 4, 5].

Landfills significantly contribute to greenhouse gas emissions because they produce CH₄ and CO₂ as constituents of landfill gas. Landfill gas production maximums occur within the 5 to 7-year period after waste deposition. Twenty years after deposition, landfill gas production is minimal and usually only in traces, while smaller amounts of gas can be emitted even after 50 years.

Serbia has over 3,600 non-sanitary landfills with uncontrolled emissions of gases. About 50 landfills in Serbia contain over 100,000 m³ of deposited waste with an estimated amount of 60,000 tonnes in 2010, and these landfills are responsible for more than 95% of methane emissions from waste [6].

LANDFILL GAS PRODUCTION

Landfill gas is produced due to bacterial activity. Its increase depends directly proportional to the content of organic waste in the landfill. Landfill gas typically contains methane (46-60 %), carbon dioxide (40-60 %), nitrogen (2-5 %), oxygen (0.1-1%), disulphides, mercaptans (0.1-1.0%), sulphides (0-1%), ammonia (0.1-1.0%), hydrogen (0-0.2 %), carbon monoxide (0-0.2%), etc.

Specific types of organic waste contain high levels of sodium, potassium, calcium, and magnesium, which stimulate bacterial activity and, consequently, increased production of landfill gas. Some other types of waste, however, contain compounds that impede bacterial activity, thus decreasing landfill gas production. Methane-producing bacterial activity is hindered by high salt content [3].

Produced landfill gas for a specific number of years can be estimated using the LandGEM emission tool (EPA) [7]:

$$Q_T = \sum_{j=1}^n 2kL_o M_i e^{-kt_i} \quad (1)$$

where: Q_T – total amount of gas produced in a landfill for the observed number of years ($m^3/year$), n – total period of waste deposition, k – landfill gas emission constant during the observed period ($year^{-1}$), L_o – potential capacity of methane production (m^3/t), M_i – mass of waste deposited over the i^{th} time period (t), t_i – age of the i^{th} section of the waste (years).

Methane production in a sanitary landfill depends on the morphological composition of waste, waste moisture content, its chemical composition, method of deposition, method of covering, climate and hydrological conditions, etc.

The amount of landfill gas is also estimated using the LandGEM emission tool (EPA). Annual amount of produced methane can be determined using the following equation [3]:

$$Q_{CH_4} = \sum_{j=1}^n \sum_{i=0,1}^j kL_o \left(\frac{M_i}{10} \right) e^{-kt_{ij}} \quad (2)$$

where: Q_{CH_4} – annual amount of produced methane ($m^3/year$), i – increment (1 year), j – increment, n – initial year of waste deposition, k – methane production rate ($year^{-1}$), L_o – potential capacity of methane production (m^3/t), M_i – mass of waste deposited in the i^{th} year (t), t_{ij} – age of the i^{th} section of the waste with a mass M_i deposited in the i^{th} year.

Methane (CH_4) is the primary product of biomass decomposition and fermentation by bacteria in anaerobic conditions. When mixed with 5-15% of air, it becomes explosive in the natural environment.

Production of methane can last over 30 years, when a landfill is completely closed and reclaimed, while the gas can evaporate for even longer than that. Being lighter than air, methane reaches the upper layers of the atmosphere. Compacted layers of waste, impermeable clay cover layer, and vegetation top layer represent obstacles causing methane to migrate up to several hundred meters away from the landfill before it reaches the atmosphere. If it is not emitted into the atmosphere, methane can accumulate inside the pockets within the landfill. On the one hand, uncontrolled emission of methane into the atmosphere can threaten any residential area in the vicinity; on the other hand, methane build-up inside landfill pockets can cause explosions at the landfill.

Landfill methane production begins when the deposited waste becomes devoid of oxygen. If the waste is compacted, methane will produce sooner, as soon as the anaerobic bacteria begin to decompose the waste. Even the smallest presence of oxygen in the landfill will decelerate methane production. Changes in atmospheric pressure can cause the environmental oxygen to penetrate the landfill body and decelerate methane production.

On the other hand, presence of specific amounts of water will increase landfill gas production. Moisture content of 40% and higher will cause maximum gas production. Good waste compactness will reduce gas production due to increased landfill density and decreased infiltration of water in each waste layer. Gas production is increased in case of heavy precipitation and permeable parts of the cover layers, which allow the water to reach the landfill body.

High temperatures increase bacterial activity, which directly boosts gas production. On the other hand, lower temperatures inhibit bacterial activity, and gas production considerably decreases below $10^\circ C$. Weather fluctuations significantly affect shallow landfills, because the bacteria are not isolated from temperature changes as they are in deeper landfills covered by thick earth layers.

Well-covered landfills maintain a stable temperature, which increases gas production. Bacterial activity releases heat, stabilizing the landfill temperature between 25 and $45^\circ C$. However, temperatures up to $70^\circ C$ were registered in some landfills and higher temperatures create favourable conditions for certain chemical reactions.

Landfills usually produce considerable amounts of gas between their first and third year of waste deposition, but the maximum amounts are produced between the fifth and seventh year. Twenty years after waste deposition, landfill gas production is minimal and only occurs in traces; yet, insignificant amounts of gas can be produced even after 50 years. Different sections of a landfill can simultaneously

go through different phases of waste decomposition, which depends on waste age [3].

During the first years of landfill use, CO₂ is predominantly produced to be equated over time with methane production. Contributory factors for landfill production include bacterial decomposition of waste, volatilization, and chemical reactions. Most of the landfill gas is produced through bacterial decomposition of waste. Since municipal waste mostly includes organic waste, such as food, garden waste, street litter, textile, wood, and paper, the bacteria inside the landfill decompose the waste in four phases, while the composition of the gas changes during each phase. Landfill gas is also produced when the compounds produced by waste decomposition, especially organic compounds, change their state from liquid or solid to gaseous. This process is called volatilization. Non-methane organic compounds in landfill gas can be the result of volatilization of specific compounds in the landfill. Landfill gas, including the non-methane organic compounds, can be produced by the reactions of specific compounds in the landfill [3].

LANDFILL GAS PRODUCTION BY DECOMPOSITION PHASES OF DEPOSITED WASTE

Decomposition of deposited waste proceeds in four phases: Phase I – aerobic phase; Phase II – anaerobic phase (non-methanogenic phase); Phase III – anaerobic (unstable methanogenic phase); and Phase IV – anaerobic (stable methanogenic phase).

Phase I – aerobic phase

Phase I (aerobic decomposition of deposited waste) proceeds over a relatively short period after waste deposition and covering of the landfill with earth. Decomposition of organic and biodegradable waste components proceeds under the influence of aerobic microbes. During phase I, aerobic bacteria utilize oxygen, breaking the long molecular chains of complex compounds that constitute organic waste, such as hydrocarbons, proteins, and fats. At the beginning of the phase, nitrogen concentration is quite high (around 20% oxygen and 80% nitrogen), but it decreases with the subsequent decomposition phases. Phase I proceeds until the available oxygen is completely depleted. This phase can last for days or months, depending on how much oxygen is present at the moment of waste deposition. Levels of oxygen from the air in the landfill body will vary depending on waste compactness, and the levels can be decreased by compacting the waste using tracked compaction tractors.

Carbon dioxide and heat are released during phase I, with the temperature ranging from 50 to 70°C, as are partially decomposed organic compounds. This phase produces mildly acidic leachate, with high COD (chemical oxygen demand) levels. The acidic nature of the leachate enables the release of multiple organic compounds, as well as metals [7].

Phase II – anaerobic phase (non-methanogenic phase)

This phase begins when the oxygen is reduced until it no longer supports the aerobic decomposition. Carbon dioxide is still produced during phase II, the temperature keeps dropping, and large amounts of partially decomposed organic compounds, especially organic acids, are formed. Through anaerobic processes, the bacteria convert the compounds produced by aerobic bacteria into acetic, lactic, formic, and other acids, as well as alcohols, such as methanol and ethanol. Because of these processes the landfill environment becomes acidic. Since the acids mix with the moisture inside the landfill, nutrients become dissolved, so the different types of bacteria are provided with nitrogen and phosphorus. These processes produce carbon dioxide and hydrogen as their gaseous by-products. However, if the hydrogen reaches the landfill, the microbiological processes will revert to aerobic phase I. In phase II, hydrolysis (extracellular enzyme process) occurs first, whereby organic matter is transformed into water-soluble components. This process requires a significant moisture content as well as physical contact between the microorganisms and the waste [3]. Gaseous compounds are not generated during the hydrolysis phase. The formed monosaccharides and higher organic acids are converted by microbes through different metabolic processes into simpler organic acids, water, carbon dioxide, ammonia, and hydrogen. During this phase, in which the acids are fermented, SO₂ is generated immediately after the process is initiated.

Phase III – anaerobic (unstable methanogenic phase)

This phase of decomposition of deposited waste begins when specific types of anaerobic bacteria feed on the organic acids produced during phase II and start forming acetates. The process renders the environment pH neutral, ca. pH=7, which is favourable for the methanogenic bacteria. The acidogenic bacteria produce compounds on which methanogenic bacteria feed. Methanogenic bacteria feed on carbon dioxide and acetates, which are toxic to acidogenic bacteria at high concentrations. Phase III usually begins six months after waste deposition and can last up to 17 months.

Phase IV – anaerobic (stable methanogenic phase)

Methanogenic phase IV involves the decomposition of deposited waste dominated by anaerobic microorganisms (methanogenic bacteria). This phase begins when both the composition and the production of landfill gas become relatively constant. The landfill gas then contains around 45-60 % methane, 40-60 % carbon dioxide, and 2-9 % trace gases. It is constantly produced during phase IV over about 20 years, but gas emissions can continue for as long as 50 years after the initial waste deposition. Gas production can take longer especially if there is a larger amount of organic waste.

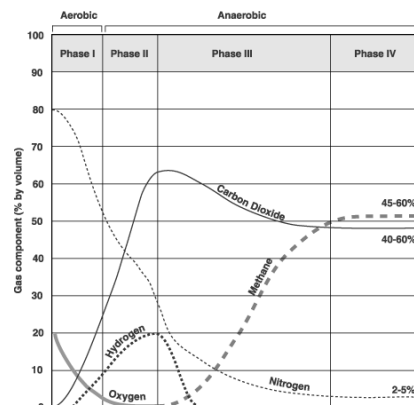

Fig. 1. Production phases of typical landfill gas [8]

METHANE AND CARBON DIOXIDE CONCENTRATIONS AT “BUBANJ” NON-SANITARY LANDFILL IN NIŠ

“Bubanj” municipal waste landfill is located in the southwestern portion of the Niš Valley. Waste has been deposited at “Bubanj” landfill since 1968, covering the city of Niš, Niška Banja, the suburban settlements of Čamurlija, Grabovac, Jelašnica, Čukljenik, Gornja Studena, Gornja Toponica, residential portion of Knez Selo, and the villages of Popovac and Doljevac. The landfill stretches over a total area of 31.07 ha. It is located 6 km away from the Niš city centre, but only 200-300 metres from the nearest houses.

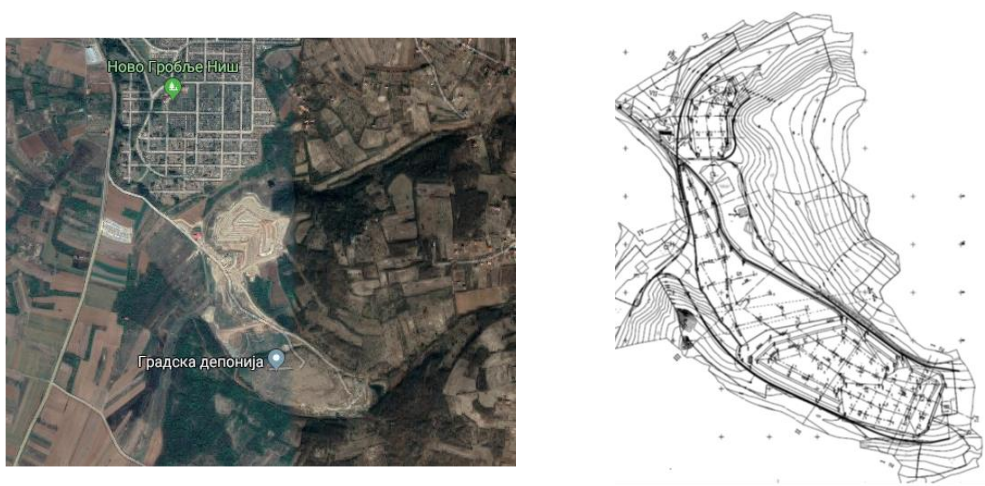

Fig. 2. Layout of sections S1, S2, S3, and S4 at “Bubanj” non-sanitary landfill in Niš

“Bubanj” landfill receives municipal waste, which is distributed across the surface and covered with earth and other inert materials. Through organic matter decomposition initiated by microorganisms in anaerobic conditions, the landfill generates landfill gas, which is emitted into the external ambient air through a system of gas wells, which are used for degassing. Measurements of emission concentrations of methane and carbon dioxide at “Bubanj” landfill were conducted on three sections (S2, S3, and S4) (Fig. 2) and 50 gas wells. Section S4 (Fig. 3) is the only active section, which has been in use since 2010 and which stretches over an area of 2.85 ha. Sections S2, S3, and S4 are equipped with passive degassing systems. Sections S2 and S3 were closed for waste deposition in 2010 and reclaimed, having previously received waste since 1968.

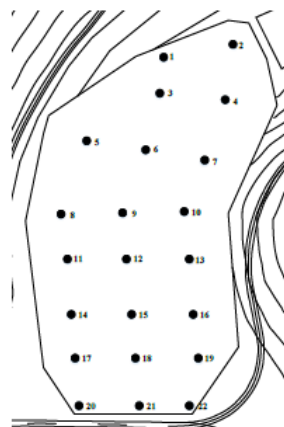

Fig.3. Layout of gas wells in the active section S4

Atmospheric conditions during landfill gas sampling were as follows: external air temperature of 15°C, relative air humidity of 55%, wind speed of 4km/h, and atmospheric pressure of 1011.2 mbar. Table 1 provides the measured emission concentrations of methane and carbon dioxide from landfill sections S2, S3, and S4. The measurements were conducted in February 2020.

Table 1. Emission concentrations of methane and carbon dioxide at “Bubanj” non-sanitary landfill in Niš

SECTION S2				SECTION S3			
Gas well	CH ₄ (% vol.)	CO ₂ (% vol.)	Depth (m)	Gas well	CH ₄ (% vol.)	CO ₂ (% vol.)	Depth (m)
3	14.8	6.5	3.9	2	12.2	8.6	3.9
4	13.2	9.2	3.6	3	9.4	4.6	3.5
5	4.9	3.2	3.9	6	8.4	5.3	3.5
8	5.3	3.0	3.8	7	9.9	5.0	3.5
12	13.9	6.9	3.8	8	5.5	2.0	3.8
13	22.1	8.5	3.7	10	8.8	4.9	3.8
14	16.2	10.5	3.7	11	12.5	6.5	3.4
15	14.8	7.1	3.8	12	8.6	5.4	3.6
16	20.3	14.1	3.5	14	9.6	5.3	3.8
17	6.8	3.0	3.8	15	6.9	4.4	3.9
21	9.1	4.5	3.9	16	13.2	7.0	3.6
26	12.0	7.2	3.5	17	9.5	4.9	3.5
-	-	-		19	4.5	2.0	3.3
SECTION S4				SECTION S4			
Gas well	CH ₄ (% vol.)	CO ₂ (% vol.)	Depth (m)	Gas well	CH ₄ (% vol.)	CO ₂ (% vol.)	Depth (m)
1	2.5	1.2	4.3	14	27.5	8.4	7.0
2	39.5	28.7	4.7	15	17.7	8.4	6.4
3	20.1	16.5	4.6	16	9.4	5.5	6.8
4	11.9	5.4	4.3	17	13.3	8.5	6.9
5	31.2	13.0	5.5	18	18.5	12.2	6.5
6	19.3	10.0	5.4	19	26.8	14.3	7.4
7	6.5	3.2	5.5	20	18.5	10.4	8.4
8	50.6	37.4	6.4	21	31.5	19.4	7.3
9	23.2	15.2	6.4	22	14.5	6.2	5.1
10	33.4	19.4	5.3	23	17.3	13.5	6.2
11	45.2	34.9	7.5	24	22.3	12.1	6.2
12	15.5	6.2	6.5	25	13.5	9.3	6.4
13	9.5	6.8	6.8	-	-	-	

In the inactive section S2, measured methane concentrations range from 4.9 to 22.1(% vol.), while carbon dioxide concentrations range from 3.0 to 14.1 (% vol.). Gas well depths in this section range from 3.5 to 3.9 m. The highest methane concentration (22.1 % vol.) was registered on gas well 13 (3.7m deep), while the highest concentration of carbon dioxide (14.1 % vol.) was registered on gas well 16 (3.5m deep).

In the inactive section S3, measured methane concentrations range from 4.5 to 13.2(% vol.), while carbon dioxide concentrations range from 2.0 to 8.6 (% vol.). Gas well depths in this section range from 3.3-3.9 m. The highest methane concentration (12.5 % vol.) was registered on gas well 11 (3.4m deep), while the highest concentration of carbon dioxide (8.6 % vol.) was registered on gas well 2 (3.9 m deep).

Section S4 has been active for ten years and its measured methane concentrations range from 2.5 to 50.6(% vol.), while carbon dioxide concentrations range from 1.2-37.4 (% vol.). Gas well depths in this section range from 4.3 to 4.9 m. The highest methane concentration (50.6 % vol.) was registered on gas well 8 (3.4m deep), while the highest concentration of carbon dioxide (37.4 % vol.) was also registered on gas well 8.

Emission concentrations of methane and carbon dioxide from inactive sections S2 and S3 were lower than the concentrations from the active section S4, which is in accordance with the previous theoretical considerations (Fig. 1). Landfill age and waste decomposition phases indicate both an increase and a decrease in emitted gas concentrations. The maximum methane emission is to be

expected during the first five years of the landfill's use, subsequently decreasing due to slower waste decomposition. Section S4 has been in use for ten years and, compared to sections S2 and S3, which still exhibit somewaste decomposition, albeit much slower, it was expected to emit higher concentrations of methane. The measurement results also show that emitted methane concentrations are higher than carbon dioxide concentrations and that waste decomposition at "Bubanj" landfill is currently in phase IV. With regard to gas wells, their depths are almost twice higher in section S4, which suggests that increased methane emissions in S4 are due to decomposition of larger amounts of waste.

CONCLUSION

Landfill gas is a flammable and potentially hazardous mixture of gases, mostly composed of methane (CH₄) and carbon dioxide (CO₂) with traces of volatile organic compounds (VOC). It is estimated that methane emissions from landfills constitute 3-19% of the total global anthropogenic methane emissions. Methane from landfills can be collected and used as a renewable energy source. If not collected, but released into the atmosphere, as is the case at "Bubanj" landfill, methane contributes to global warming. If there is no option to collect it, a better alternative is to use landfill gas flaring than to release it into the atmosphere.

"Bubanj" non-sanitary landfill is equipped with a passive degassing system for the landfill gas emitted into ambient air. The waste at the landfill is currently in phase IV of decomposition, during which landfill gas is usually constantly produced over about 20 years, but gas emissions can continue even 50 years after waste deposition. Gas production can sometimes take longer, especially if the landfill contains a larger amount of organic waste.

ACKNOWLEDGMENTS

This study is financed by the Serbian Ministry of Education, Science and Technological Development.

REFERENCES

- [1] EPA, United States Environmental Protection Agency, International anthropogenic methane emissions: estimates for 1990, Office of Policy, Planning and Evaluation, Washington, DC. US EPA, 1994.
- [2] Cheremisinoff, N. P., Hand book of Solid Waste Management and Waste Minimization Technologies, Elsevier Sciences, 2003.
- [3] Radosavljević, J., Đorđević, A., Deponije i deponovanje komunalnog otpada [Landfills and Municipal Waste Deposition], Fakultet zaštite na radu, Niš, 2012.
- [4] Akesson, M., Nilsson, P., Material Dependence of Methane Production Rates in Landfills, Waste Management & Research, 16 (1998), 2, pp. 108-118.
- [5] Meres, M., et. al., Operational and Meteorological Influence on the Utilized Biogas Composition at the Barycz Landfill Site in Cracow, Poland, Waste Management & Research, 22 (2004), 3, pp. 195-201.
- [6] Stanisavljevic, N., D. Ubavin, B. Batinic, J. Fellner, G. Vujic, Methane emissions from landfills in Serbia and potential mitigation strategies: a case study. Waste Management & Research: p. 0734242X12451867, 2012.
- [7] Pichtel, J., Waste Management Practices: Municipal, Hazardous and Industrial. Taylor & Francis, 2005.
- [8] EPA, United States Environmental Protection Agency, Solid waste disposal facility-technical manual. Washington, DC. US EPA, 1997.

EFFECTS OF SUNSPACE GEOMETRY ON THE ENERGY PROPERTIES OF DETACHED APARTMENT BUILDINGS

Ana Vukadinović¹, Jasmina Radosavljević¹

¹University of Niš, Faculty of Occupational Safety in Niš, Serbia

e-mail: ana.vukadinovic@znrfak.ni.ac.rs

Abstract: This paper examines the energy properties of passive detached apartment buildings with a sunspace in relation to sunspace geometry. The total amount of energy required for building heating and cooling was calculated by means of dynamic modeling using EnergyPlus™ software. The simulations were run according to the meteorological parameters for the city of Niš, Serbia. For simulation purposes, models of residential buildings with a passive sunspace were designed. The variations between the models include different sunspace floor geometry and different ratios of sunspace length to south-facing façade length. The effects of sunspace geometry on the energy performance of buildings are considered for the following sunspace widths: 1.2 m, 1.5 m, 1.8 m, 2.4 m, 3.0 m, and 3.6 m, as well as for the ratio of sunspace and south-facing façade lengths. The most favorable building model subvariant for the three main variants is S1, which has the narrowest sunspace (1.2 m). The total energy required for heating and cooling of the three subvariants is 2.21%, 2.77%, and 5.07% less than the model without a sunspace. In addition, the models with a sunspace that covers the entire south-facing façade exhibit better energy efficiency compared to the models in which the sunspace covers only half of the south-facing façade.

Key words: residential building, sunspace, geometry, energy required for heating and cooling

INTRODUCTION

Sunspaces connect the indoor space of a building with the outdoor environment. Proper sunspace design can improve the energy efficiency of a building as well as its aesthetic value. Sunspaces are usually installed on the south-facing façade of a building and it can cover the entirety or only a portion of the façade. Depending on its size, a sunspace can reduce heat loss and increase heat gain in a building.

Babae et al. [1] examined the optimal sunspace geometry in passive buildings in the city of Tabriz, located in a colder region of north-western Iran. Their study was conducted on a terraced apartment building with two thermal zones (sunspace and indoor space). They used a simulation to calculate the monthly and annual energy required for heating and cooling of the building with a sunspace. The influence of building orientation on energy consumption was analyzed. For the climate conditions of Iran, the south-facing orientation (0°) is optimal for passive heating of a passive building with a sunspace, with the maximum deviation of 10°. For the given model of a passive building with a sunspace, Babae et al. examined the optimal sunspace width. Their research included models with sunspace widths of 1.5 m, 2 m, 2.5 m, and 3 m. Their results revealed that the most favorable sunspace width in terms of heating energy consumption was 1.5 m. The authors compared the heating energy consumption in a building model with optimal-geometry sunspace against a building model without a sunspace. The results showed that the heating energy consumption in the former model was 46% lower than in the latter model, which has no sunspace [1].

Among the more recent studies of passive sunspace systems, the study by Ulpiani et al. [2] is particularly noteworthy. The study focused on analyzing the energy savings of a building with an integrated sunspace in the Mediterranean climate. The study was conducted using EnergyPlus™ dynamic simulations. The simulated models included sunspaces with different window-to-wall ratios (WWR=0%, WWR=30%, and WWR=50%), different glazing type (single glazing, double glazing), different sunspace floor width (1.5 m; 2 m; 2.2 m; 2.5 m), and with or without an opening in the partition wall. The obtained results showed that the sunspace model variant with the width of 1.5 m and with double glazing was the most favorable in terms of energy performance. The heating energy savings in this model with a sunspace WWR of 50% were 78.6 kWh, or 8.40% more than the reference model without a sunspace. For the 1.5 m wide sunspace model, the authors also examined variants in which air was introduced to the indoor space through mechanical circulation. This model had 30% better energy properties than the model without the mechanical circulation of air. The study

demonstrated that a sunspace can save up to 8.4% in energy even in well-insulated buildings with low energy consumption [2].

So far, no studies of the effects of sunspace size on the energy properties of detached apartment buildings have been conducted for the climate conditions of Serbia and the city of Niš. This paper applies dynamic simulation using EnergyPlus™ software to examine the energy properties of passive detached apartment buildings with a sunspace, with different sunspace floor geometries.

MATERIAL AND METHODS

The effects of the sunspace of a passive detached apartment building on the energy required for heating and cooling were analyzed by means of dynamic simulation using EnergyPlus™ software [3]. According to this method, the energy properties of a building are calculated using simulations based on heat balance equations. The simulation program operates by simulating the interaction of the geometric building model with different external conditions, people who are present, various operating regimes, and the use of different energy systems (heating, cooling, ventilation) [4].













The preset location of the MODEL of a building with a sunspace is the city of Niš, which is located at 43°19' latitude and 21°54' longitude, and at the altitude of 202 masl.

The analysis of the effects of sunspace geometry on the energy efficiency of detached apartment buildings was conducted on building MODELS with an aspect ratio of 2.25:1, whereby the longer side facing the south [5].

Three variants of a detached apartment building with a sunspace were designed: MODEL-I, MODEL-II, and MODEL-III. MODEL-I (Table 1) has only the ground floor (G), a rectangular floor base with an aspect ratio of 2.25:1 and an area of 92.16 m², and the south-facing façade with a length of 14.4 m. MODEL-II (Table 1) has only the G level, a rectangular floor base with an aspect ratio of 2.25:1 and an area of 184.32 m², and the south-facing façade with a length of 20.36 m. MODEL-III (Table 1) has G+1 levels, a rectangular floor base with an aspect ratio of 2.25:1 and an area of 184.32 m², and the south-facing façade with a length of 14.4 m. The floor area of MODEL-II and MODEL-III is twice as large as the floor area of MODEL-I. The floor area of MODEL-III is the same as in MODEL-II, but MODEL-III has more levels (G+1). The level height in all considered models is constant at 3.0 m. The capacity of MODEL-I is 276 m³, whereas the capacity of MODEL-II and MODEL-III is 552 m³.

Additionally, subvariants of the MODEL were designed according to sunspace geometry. The reference models MODEL-I S0, MODEL-II S0, and MODEL-III S0 do not have a sunspace (Table 1). Addition of a sunspace to the reference models yielded the subvariants MODEL-I S1 to S12, MODEL-II S1 to S12, and MODEL-III S1 to S12. The subvariants MODEL-I S1 to S6, MODEL-II S1 to S6, and MODEL-III S1 to S6 include buildings with a sunspace installed over the entire length of the south-facing façade. The sunspace width in all MODEL subvariants S1 to S6 is given in Table 1. The subvariants MODEL-I S7 to S12, MODEL-II S7 to S12, and MODEL-III S7 to S12 include buildings with a sunspace covering a half of the length of the south-facing façade. The sunspace width of in MODEL subvariant S7 to S12 is also given in Table 1.

Table 1. Subvariant models of a building containing a sunspace with different floor geometries

	MODEL SUBVARIANTS												
	S0	S1	S2	S3	S4	S5	S6	S7	S8	S9	S10	S11	S12
Sunspace width [m]	–	1.2	1.5	1.8	2.4	3.0	3.6	1.2	1.5	1.8	2.4	3.0	3.6
Ratio of sunspace length and the south-facing façade length	–	1:1	1:1	1:1	1:1	1:1	1:1	1:2	1:2	1:2	1:2	1:2	1:2
													
	MODEL-I												
Building floor area [m ²]	92.16												
Sunspace floor area [m ²]	0	17.28	21.6	25.92	34.56	43.2	51.84	8.64	10.8	12.96	17.28	21.6	25.92
	MODEL-II												
Building floor area [m ²]	184.32												
Sunspace floor area [m ²]	0	24.43	30.54	36.65	48.86	61.08	73.29	12.21	15.27	18.32	24.43	30.54	36.64
	MODEL-III												
Building floor area [m ²]	184.32												
Sunspace floor area [m ²]	0	34.56	43.2	50.4	69.12	86.4	103.68	17.28	21.6	25.92	34.56	43.2	51.84

The analyzed properties for all subvariants include total energy required for heating and cooling, total energy required only for heating, and total energy required only for cooling, depending on the sunspace geometry.

The sunspace was modeled as a separate thermal zone [5] and it represents a usable area that is not mechanically heated or cooled. The sunspace is glazed throughout (its WWR is 100%), the WWR of the south-facing façade is 20%, whereas the WWR of other façades is 0%. The window-to-wall ratio thus defined will allow us to determine the effects of the sunspace on the building's energy properties without any interfering effects of the window-to-wall ratios of other façades. Figure 1 shows the 3D representation of the subvariants MODEL-I S1, MODEL-II S1, and MODEL-III S1.

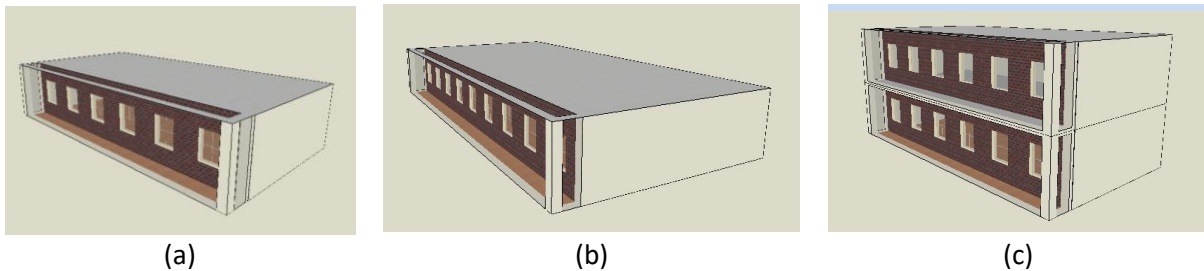

Fig. 1. Three-dimensional representation of model subvariants: (a) MODEL-I S1, (b) MODEL-II S1, (c) MODEL-III S1

When designing the model of the building with a sunspace, we also defined the elements of the thermal envelope. Table 2 provides the values of the heat transfer coefficient (U -value) for the façade walls, the floor, the roof, and the windows of the basic model of the detached apartment building with a sunspace.

Table 2. Heat transfer coefficient (U -values) for the defined thermal envelope elements in the building [6]

Building elements	U [W/m^2K]
Façade wall	0.29
Base floor	0.28
Flat roof	0.15
Windows	1.50
Sunspace WWR	1.50

The projected temperature is $20^{\circ}C$ for the heating system and $25^{\circ}C$ for the cooling system. Air infiltration in the analyzed building models is 0.700 ac/h.

RESULTS AND DISCUSSION

Analysis of the energy required for heating and cooling of building model variants with different sunspace geometries

Figures 2, 3, and 4 show the total annual energy required for heating and the total annual energy required for cooling of the observed subvariants of MODEL-I, MODEL-II, and MODEL-III with different floor geometries of the sunspace (Table 1).

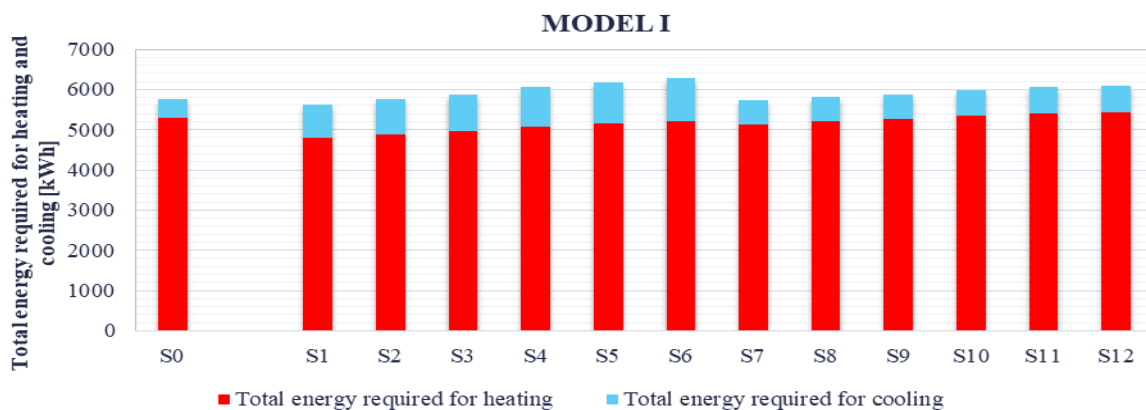

Fig. 2. Total annual energy required for heating and cooling for MODEL-I subvariants S0 to S12 with different sunspace dimensions

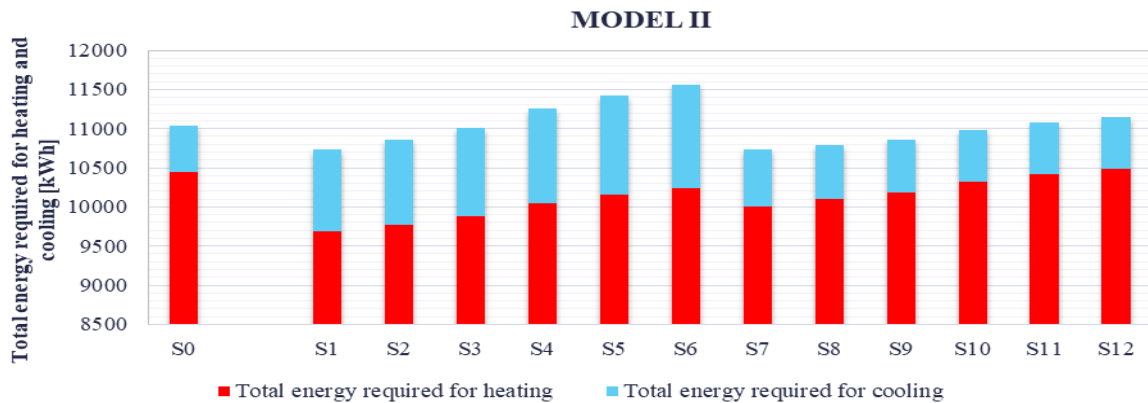

Fig. 3. Total annual energy required for heating and cooling for MODEL-II subvariants S0 to S12 with different sunspace dimensions

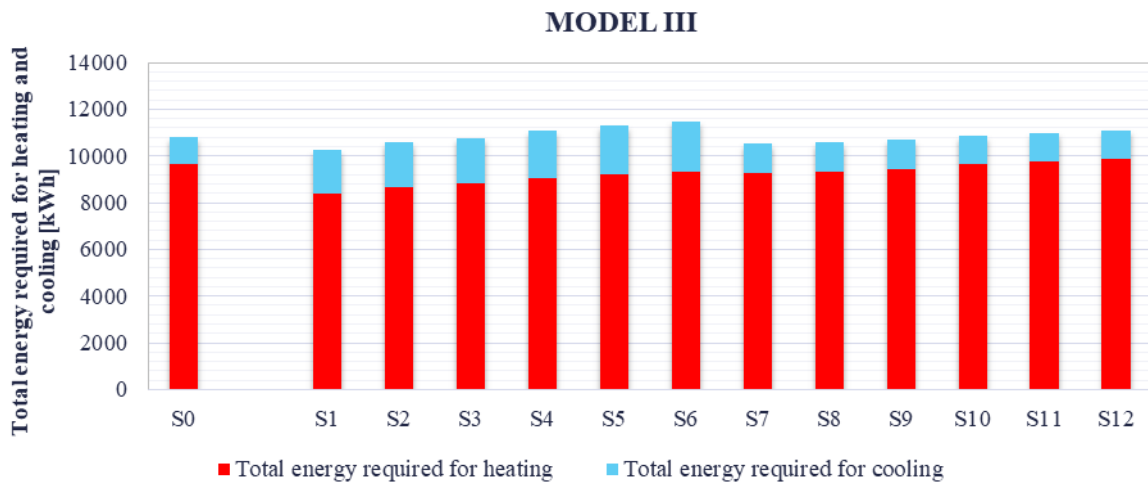

Fig. 4. Total annual energy required for heating and cooling for MODEL-III subvariants S0 to S12 with different sunspace dimensions

Table 3 shows the percentages of the decrease and increase of the total energy required for heating, the total energy required for cooling, and the total energy required for heating and cooling of the subvariants S0 to S12 for MODEL-I, MODEL-II, and MODEL-III, with different sunspace geometries.

Table 3. Percentage of increase (+) and decrease (-) of the total energy required for heating and cooling of a building with a sunspace for MODEL-I, MODEL-II, and MODEL-III against the reference model S0

	SUBVARIANTS OF MODEL-I												
	SUBVARIAN T S0	SUBVARIAN T S1	SUBVARIAN T S2	SUBVARIAN T S3	SUBVARIAN T S4	SUBVARIAN T S5	SUBVARIAN T S6	SUBVARIAN T S7	SUBVARIAN T S8	SUBVARIAN T S9	SUBVARIAN T S10	SUBVARIAN T S11	SUBVARIAN T S12
Percentage of increase (+) and decrease (-) of the total energy required for heating	ref. MODEL	- 9.69%	- 7.88%	- 6.44%	- 4.36%	- 2.97%	- 1.98%	- 3.10%	- 1.77%	- 0.72%	+0.81%	+1.74%	+2.34%

Percentage of increase (+) and decrease (-) of the total energy required for cooling	ref. MODEL	+86.35%	+95.81%	+104.10%	+118.38%	+130.54%	+140.78%	+29.54%	+33.18%	+36.53%	+41.71%	+46.28%	+49.85%
Percentage of increase (+) and decrease (-) of the total energy required for heating and cooling	ref. MODEL	-2.21%	+0.19%	+2.16%	+5.19%	+7.42%	+9.13%	-0.56%	+0.95%	+2.18%	+3.99%	+5.20%	+6.04%
	SUBVARIANTS OF MODEL-II												
	SUBVARIAN T_S0	SUBVARIAN T_S1	SUBVARIAN T_S2	SUBVARIAN T_S3	SUBVARIAN T_S4	SUBVARIAN T_S5	SUBVARIAN T_S6	SUBVARIAN T_S7	SUBVARIAN T_S8	SUBVARIAN T_S9	SUBVARIAN T_S10	SUBVARIAN T_S11	SUBVARIAN T_S12
Percentage of increase (+) and decrease (-) of the total energy required for heating	ref. MODEL	-7.35%	-6.55%	-5.45%	-3.85%	-2.78%	-2.01%	-4.23%	-3.42%	-2.60%	-1.30%	-0.33%	+0.40%
Percentage of increase (+) and decrease (-) of the total energy required for cooling	ref. MODEL	+78.35%	+84.31%	+91.56%	+104.04%	+114.80%	+123.89%	+24.13%	+18.05%	+16.02%	+13.81%	+12.57%	+11.86%
Percentage of increase (+) and decrease (-) of the total energy required for heating and cooling	ref. MODEL	-2.77%	-1.70%	-0.27%	+1.92%	+3.50%	+4.71%	-2.72%	-2.27%	-1.60%	-0.49%	+0.36%	+1.01%
	SUBVARIANTS OF MODEL-III												
	SUBVARIAN T_S0	SUBVARIAN T_S1	SUBVARIAN T_S2	SUBVARIAN T_S3	SUBVARIAN T_S4	SUBVARIAN T_S5	SUBVARIAN T_S6	SUBVARIAN T_S7	SUBVARIAN T_S8	SUBVARIAN T_S9	SUBVARIAN T_S10	SUBVARIAN T_S11	SUBVARIAN T_S12
Percentage of increase (+) and decrease (-) of the total energy required for heating	ref. MODEL	-13.21%	-10.29%	-8.77%	-6.38%	-4.68%	-3.36%	-4.01%	-3.26%	-2.07%	-0.14%	+1.19%	+2.20%
Percentage of increase (+) and decrease (-) of the total energy required for cooling	ref. MODEL	+63.68%	+68.64%	+71.67%	+77.52%	+83.43%	+88.67%	+10.63%	+8.79%	+7.78%	+6.76%	+7.28%	+7.86%
Percentage of increase (+) and decrease (-) of the total energy required for heating and cooling	ref. MODEL	-5.07%	-1.93%	-0.25%	+2.50%	+4.65%	+6.38%	-2.46%	-1.98%	-1.03%	+0.59%	+1.84%	+2.80%

According to the results shown in Figures 2, 3, and 4 and in Table 3, obtained by means of simulations using EnergyPlus™ software, out of all considered models (MODEL-I, MODEL-II, and MODEL-III), subvariant S1, with a 1.2 m wide sunspace for all three model variants, is the most favorable in terms of the total energy required for heating and cooling, only heating, or only cooling.

In MODEL-I, the detached building MODEL-I S1 requires 9.69% less energy for heating than the reference model without a sunspace (MODEL-I S0). In MODEL-II, the detached building MODEL-II S1 requires 7.35% less energy for heating than the reference model without a sunspace (MODEL-II S0). The subvariant MODEL-III S1 requires 13.21% less energy for heating than the reference model without a sunspace (MODEL-III S0) (Table 3).

The obtained results reveal that sunspace width affects energy consumption for both heating and cooling, thus also affecting the total annual required energy. The examined models with a narrower sunspace (1.2 m and 1.5 m) have better energy properties than the models with a wider sunspace (from 1.8 m to 3.6 m). Installation of a sunspace over the entire south-facing façade is more efficient than the installation over only a half of the façade (Table 3).

The results indicate that the most favorable width energy-wise for MODEL-I, MODEL-II, and MODEL-III is 1.2 m.

CONCLUSION

This paper has shown that sunspace geometry in the observed detached apartment building models (MODEL-I, MODEL-II, and MODEL-III) affects the energy efficiency of the buildings. The effects were analyzed for sunspace widths of 1.2 m, 1.5 m, 1.8 m, 2.4 m, 3.0 m, and 3.6 m, as well as for the ratio of sunspace length to the south-facing façade length. Models with narrower sunspace exhibited better energy properties, with S1 subvariant, 1.2 m wide, being the most favorable option. The subvariant MODEL-I S1 required 9.69% less energy for heating than the reference model without a sunspace; the subvariant MODEL-II S1 required 7.35% less energy for heating than the reference model without a sunspace; and the subvariant MODEL-III S1 required 13.21% less energy for heating than the reference model without a sunspace. The aforementioned subvariants required 2.21%, 2.77%, and 5.07% less energy for heating and cooling, respectively, than the model without a sunspace. Finally, sunspace models that cover the entire south-facing façade exhibited improved energy efficiency over the sunspace models covering only half of the south-facing façade.

ACKNOWLEDGMENTS

This study is financed by the Serbian Ministry of Education, Science and Technological Development.

REFERENCES

- [1] Faezeh, B., Fayaz, R., Sarshar, M., 2016. „*The optimum design of sunspaces in apartment blocks in cold climate*” *Architectural Science Review* 59, no. 3: 239-253.
- [2] Ulpiani, G., Giuliani D., Romagnoli, A., di Perna, C., 2017. „*Experimental Monitoring of a Sunspace Applied to a NZEB Mock-up: Assessing and Comparing the Energy Benefits of Different Configurations*.” *Energy and Buildings* 152 (October): 194–215. <http://linkinghub.elsevier.com/retrieve/pii/S0378778816315390>.
- [3] US Department of. Energy. *Engineering Reference*, EnergyPlus™ Version 9.1.0 Documentation, 2019.
- [4] Vishal, G., Jyotirmay, M., Surekha, T., Aviruch, B., 2003. „Building Energy Simulation”.
- [5] Vukadinović, A., Radosavljević, J., Đorđević, A., Petrović, N. *Effects of the geometry of residential buildings with a sunspace on their energy performance*, FACTA UNIVERSITATIS Series: Architecture and Civil Engineering Vol. 17, No 1, 2019, pp. 105-118. <https://doi.org/10.2298/FUACE190227004V>
- [6] Vukadinović, A. Radosavljević, J. Đorđević, A. *Energy performance impact of using phase-change materials in thermal storage walls of detached residential buildings with a sunspace*, *Solar Energy*, Volume 206, 2020, pp. 228-244, ISSN 0038-092X, <https://doi.org/10.1016/j.solener.2020.06.008>

CAUSE-AND-EFFECT RELATIONSHIP BETWEEN CARBON MONOXIDE CONCENTRATIONS IN AMBIENT AIR AND RESPIRATORY DISEASES IN PRESCHOOL CHILDREN

Amelija Đorđević¹, Ana Miltojević¹, Aca Božilov¹, Goran Janačković¹

¹University of Niš, Faculty of Occupational Safety in Niš, Niš, Serbia
e-mail: amelija.djordjevic@znrfak.ni.ac.rs, ana.miltojevic@znrfak.ni.ac.rs,
aca.bozilov@znrfak.ni.ac.rs, goran.janackovic@znrfak.ni.ac.rs

Abstract: The aim of this paper is to determine direct proportionality and cause-and-effect relationship between the occurrence of respiratory diseases and carbon monoxide concentrations in external ambient air in the city of Niš, Serbia. Predictions for carbon monoxide concentrations in external ambient air were not made using measurements but using artificial neural networks, which also helped determine the air quality fields at the analyzed locations. After that, an analysis was conducted on the causality between air pollution and the occurrence of respiratory diseases in preschool children under six. The majority of the children suffering from respiratory diseases (39.48%) are from locations with high mean annual carbon monoxide concentrations (7.8 mg/m³), to which the children were exposed.

Key words: air quality index, air quality mapping, RBF network, carbon monoxide, respiratory diseases

INTRODUCTION

Use of unclean technologies, uncontrolled use of fossil fuels, expansion of transport, and the modern way of life in urban environments produce ever-increasing emissions of pollutants, which seriously threaten the environment and the health of the exposed population.

The interaction between people and the environment, which involves matter and energy exchange, as well as defence and protection processes, adaptation, and tolerance is projected in their interrelations, which are not relations of simple reciprocity, but rather complex processes of people-environment interaction.

In present-day society, ridden with chemical environmental pollution, respiratory, cardiovascular, immunological, endocrine, and malignant diseases are becoming more frequent and relevant, exhibiting new pathological characteristics.

Essentially, there is no way to adapt to the new conditions of environmental protection, but it is possible to adapt to them, albeit to a limited extent, qualitatively, quantitatively, and temporally. After the adaptation mechanisms have been exhausted and the threshold of tolerance and capacity of protective and defensive mechanisms has been broken, pathophysiological reactions emerge, more or less manifesting as different types of pathological conditions, or the diseases of modern civilization, often referred to as environmental diseases.

Therefore, current scientific research is justifiably focused on establishing the developmental, spatial, and temporal connections between air pollution and the risks it poses for human health.

According to the WHO, 4.3 million global deaths in 2012 were caused by indoor air pollution [1], while additional 3 million deaths were caused by outdoor air pollution [2]. The WHO data also report around 169,000 deaths in children under five due to the effects of external ambient air pollution [1,2].

The probability of children under five dying due to exposure to polluted air is 60 times higher in countries with low and medium net national income than in countries with high net national income [3].

Meta-analysis has shown that there is a link between gaseous emissions from motor fuel combustion (traffic exhaust emissions) and pneumonia in very young children as well as a link between air pollution and middle-ear infection [4].

Results from one study [5] showed that primary pollutants originating from traffic worsen the infections of upper and lower respiratory tract already in early childhood.

This and similar studies conducted worldwide, including the one by the present authors, published in 2009 in the journal *Environmental Monitoring and Assessment*, Vol. 158, entitled *Air Quality Monitoring in Niš (Serbia) and Health Impact Assessment*, were the basis for the project *Improvement*

of the system for monitoring and assessment of long-term population exposure to environmental pollutants using neural networks, headed by the Faculty of Occupational Safety in Niš, University of Niš, Serbia (Project No. III-43014) and financed by the Serbian Ministry of Education, science and Technological Development. The studies conducted within the project from 2011 to 2018 showed that there is a cause-and-effect relationship between ambient air quality and the health of the exposed population. The studies conducted during 2011, 2012, and 2013 were focused on determining if there is a direct proportionality between ambient air quality and respiratory diseases in preschool children in two kindergartens in the city of Niš.

The analysis of the results of the studies conducted within the said project produced specific conclusions, which were presented at the Fourth International WeBIOPATRE Workshop & Conference Particulate Matter: Research and Management (Belgrade, 2013) and published in the journal *Vojnosanitetski Pregled (Military Medical Review)* (2016, 73(4): 326-336) under the title *Respiratory Diseases in Preschool Children in the City of Niš Exposed to Suspended Particulates and Carbon Monoxide from Ambient Air*.

The conducted studies were founded on the general assumption that relevant conclusions about the causality of air pollution and health risk to the exposed population could be drawn only through the organization and implementation of air quality monitoring based on a multidisciplinary approach.

To determine the causality between air pollution and health risk in preschool children (aged 6 or under), in addition to introducing a new air quality monitoring system, we expanded the research with the monitoring of respiratory diseases in children who attend six kindergartens located in parts of the city with high carbon monoxide concentrations and near streets with heavy traffic.

AIR QUALITY MAPPING USING AN RBF NETWORK

The wider, central portion of the city of Niš is located in the lowest part of the Niš Valley, which is why pollutants remain there the longest. Using a radial basis function (RBF) network, we mapped the air quality for this part of the city (Figure 1). Air quality index was used as a visible variable, an integrated dimension of the RBF network. The output data comprised the annual air quality index for the part of the city where there was no measurement of pollutant concentrations, which are regularly monitored at specific measuring locations in the monitoring network. Table 1 provides the overview of the original values of specific annual pollutant concentration levels in external ambient air (immission) in relation to the air quality index [6].

Table 1. Annual pollutant immission concentration values in terms of air quality index

Air quality category	POLLUTANT CONCENTRATIONS					Air Quality Index
	Soot [$\mu\text{g}/\text{m}^3$]	CO [mg/m^3]	SO ₂ [$\mu\text{g}/\text{m}^3$]	NO ₂ [$\mu\text{g}/\text{m}^3$]	HCHO [$\mu\text{g}/\text{m}^3$]	
Good	0.0-11.80	0.0-1.43	0.0-11.80	0.0-24.00	0-0.05	0 - 50
Moderate	11.81-50.00	1.44-3	11.81-50.00	24.01-60	0.06-0.10	51 - 100
Unhealthy for Sensitive Groups	50.01-77.77	3.01-3.95	50.01-77.77	60.01-84.00	0.11-0.14	101 - 150
Unhealthy	77.78-105.00	3.96-4.91	77.78-105.00	84.01-120.00	0.15-0.20	151 - 200
Very Unhealthy	105.56-209.72	4.92-9.70	105.56-209.72	120.00-150.00	0.21-0.24	201 - 300
Hazardous	209.73-348.61	9.71-16.86	209.73-348.61	150.01-210.00	0.25-0.35	301 - 500

The originality of the method used in this study to evaluate air quality and assess health risk lies in its ability to predict immission concentrations and to create air quality fields in the analyzed urban area by means of an RBF network.

RBF network-aided prediction of immission concentrations is simple and the obtained results are satisfactory. During the research that lasted for several years, the maximum absolute error that occurred when determining the air quality fields while mapping the air quality in Niš from 2011 to 2015 was 10^{-4} or lower.

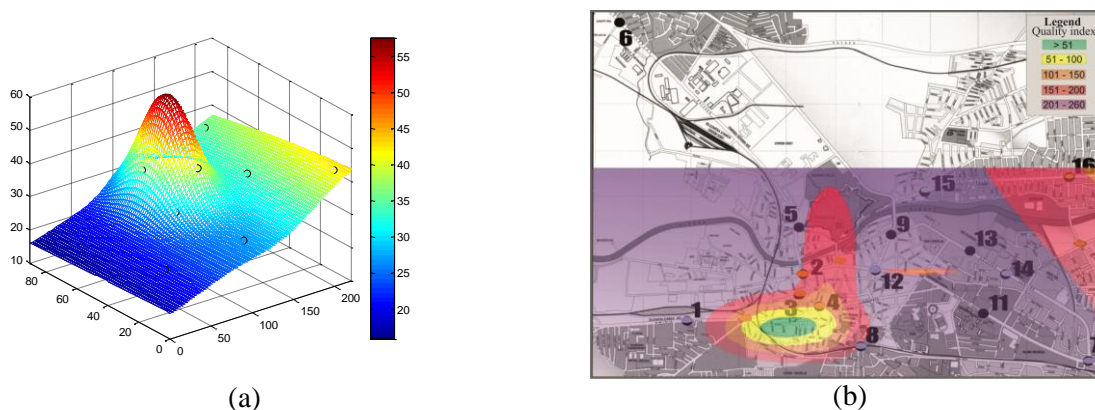

Fig. 1. (a) Approximation of the air quality index; (b) Map of air quality fields for carbon monoxide in the ambient air of the city of Niš

ANALYSIS OF CAUSE-AND-EFFECT RELATIONSHIP BETWEEN AIR QUALITY AND RESPIRATORY DISEASES IN CHILDREN

Using the RBF network and air quality mapping for the city of Niš, we established that carbon monoxide concentrations in the ambient air are high near heavy-traffic streets. It is well-known that motor fuel combustion releases gaseous substances such as partially oxidized hydrocarbons, aldehydes (acrolein and formaldehyde), nitrogen oxides, non-decomposed hydrocarbons (olefins, pentane, hexane), benzopyrene, carbon monoxide, sulphur oxides, ammonia, organic acids, lead vapours, and halogenides. Of the said pollutants, carbon monoxide, PM_{2.5} particulate matter, hydrocarbons, and nitrogen oxides are the most detrimental to air quality. Investigations of traffic flows in Niš on the major road network have shown that the main city streets have a substantially high traffic flow. The major roads internally connect residential and commercial zones, but also connect the city externally, with motorway exits. Both external and inner-city major roads are dominated by passenger vehicles, which comprise 50-80% of the total number of vehicles passing through the roads. Considering that several kindergartens operating within the “Pčelica” (Eng. *Little bee*) Preschool Institution are located near the busy major roads, inside the field of high carbon monoxide concentrations, the aim of the present study was to establish the causality between high carbon monoxide concentrations in ambient air and respiratory diseases in children aged 1 to 6.

According to the air quality fields established using the RBF network, six kindergartens were selected for analysis, all of them located in parts of the city categorized according to the air quality index as ‘unhealthy for sensitive groups’ (101-150), ‘unhealthy’ (151-200), and ‘very unhealthy’ (201-260) (Figure 2, Table 1).

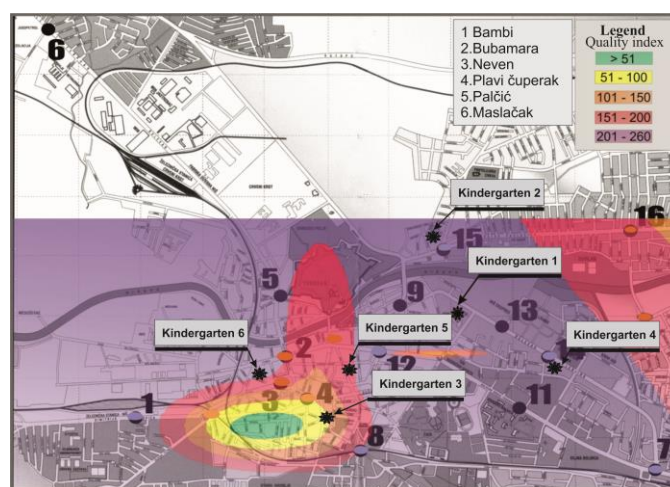

Fig. 2. Location of the analyzed kindergartens on the air quality map of the city of Niš with the air quality index for carbon monoxide concentrations

During the research period, the mean annual carbon monoxide concentrations at kindergarten 1 (“Bambi”), predicted using the RBF network, exceeded the allowed limits. Considering the vehicle frequency and structure on the adjacent intersection, the conclusion is that pollutant emission from traffic has a dominant impact on air quality. The predicted mean annual carbon monoxide concentration was 7.8 mg/m³, which corresponds to the air quality index of 260 and the air quality category of ‘very unhealthy’ (Figures 2 and 3). Predicted air quality at kindergarten 2 (“Bubamara” [Eng. *Ladybird*]) is in the same category as kindergarten 1 – very unhealthy – since the RBF network-predicted mean annual carbon monoxide concentration was 7.7 mg/m³ (air quality index of 258.57).

Analysis of the traffic impact and the micro-location of kindergarten 3 (“Neven” [Eng. *Marigold*]) revealed that specific weather conditions and lower wind speeds enable the formation of local circulation zones, in which the pollutants emitted from vehicles remain longer. Local circulation zones can lead to an increase of pollutant concentrations even when vehicle frequency is not high. This is corroborated by the fact that daily carbon monoxide concentrations exceeded the allowed limits during the analyzed period. The RBF network and air quality mapping-predicted mean annual carbon monoxide concentration for kindergarten 3 was 2.93 mg/m³, with the air quality index of 97.80 and the air quality category of ‘moderate’ (Figures 2 and 3).

For kindergarten 4 (“Plavi čuperak” [Eng. *Blonde Cowlick*]), the analysis showed that high carbon monoxide concentrations are possible. The RBF network and air quality mapping-predicted mean annual carbon monoxide concentration for ambient air at kindergarten 4 was 7.8 mg/m³, the same as kindergarten 1 (“Bambi”) (Figures 2 and 3).

Kindergarten 5 (“Palčić” [Eng. *Tom Thumb*]) is located in a central, densely populated part of the city (Figure 2). Air quality analysis revealed that vehicles have a dominant impact on the air quality in the central portion of the city and that pollutants emitted through motor vehicle exhausts can affect the health of exposed preschool children. The RBF network-predicted air quality index in terms of mean annual carbon monoxide concentrations for this kindergarten (4.8 mg/m³) was 194.33, which places it in the ‘unhealthy’ category.

Kindergarten 6 (“Maslačak” [Eng. *Dandelion*]) is located in the immediate vicinity of busy roads with considerably high frequency of passenger vehicles, light and heavy trucks, and buses and coaches. Such traffic structure in this part of the city seriously deteriorates the air quality due to emissions of high pollutant concentrations from motor vehicle exhausts. Using the RBF network, the air quality was mapped in terms of mean annual carbon monoxide concentrations, as shown in Figure 1. The air quality index for this kindergarten in the analyzed period was 200, which corresponds to the air quality category of ‘unhealthy’, with the mean annual carbon monoxide concentration of 4.91 mg/m³.

All of the observed kindergartens, with the exception of kindergarten 3, are located in areas for which the predicted ambient air carbon monoxide concentrations exceed their allowed limits. The RBF network-predicted mean annual carbon monoxide concentration for kindergarten 3 was also high and close to the allowed upper limit of 3 mg/m³.

To determine if there is a causality between carbon monoxide concentrations in external ambient air and the incidence of respiratory diseases in the exposed population aged 6 or under, we monitored the incidence of respiratory diseases in children who attended the six kindergartens. The resulting incidence of respiratory diseases is shown in Tables 2, 3, and 4.

Table 2. Incidence of respiratory diseases in children attending kindergartens 1 and 2

Respiratory disease name	Children’s age groups in kindergarten 1 (“Bambi”)					Children’s age groups in kindergarten 2 (“Bubamara” [<i>Ladybird</i>])				
	1 - 2	3	4	5	6	1 - 2	3	4	5	6
	Number of observed children					Number of observed children				
	58	63	67	68	58	51	39	65	83	50
	Annual percentage of affected children					Annual percentage of affected children				
<i>Acute pharyngitis</i>	25.43	21.84	21.89	14.12	11.22	23.59	22.84		13.67	11.23
<i>Acute tonsillitis</i>							2.44			
<i>Acute laryngitis/tracheitis</i>	1.71	3.01	2.51	2.21	1.87	2.92	1.52	1.98	1.2	1.79

<i>Respiratory tract infections</i>	6.66	9.49	7.54	8.24	4.08	12.1	7.61	8.09	5.16	6.97
<i>Influenza</i>	0.85	0.95	1.48	1.47	1.53	0.97	1.02	0.76	0.84	0.6
<i>Bronchitis; Acute bronchitis</i>	2.05	8.39	6.66	1.62	1.53	7.41	5.84	4.12	1.2	2.19
<i>Tracheitis and other obstructive pulmonary diseases</i>	2.22	4.59	1.18	1.18	1.36	0.58	1.78	0.76	0.84	0.4
<i>Bronchial asthma</i>	/	0.47	0.30	/	0.17	0.94	1.01	0.76	0.4	/
<i>Pneumonia</i>	0.51	/	0.15	/	/	0.58	0.76	0.46	0.36	0
<i>Other nose and sinus disorders</i>	1.71	1.27	1.18	0.15	/	/	0.51	0.31	/	/
<i>Chronic sinusitis</i>	/	/	0.15	0.15	/	/	0.25	0.76	0.6	/

Table 3. Incidence of respiratory diseases in children attending kindergartens 3 and 4

Respiratory disease name	Children's age groups in kindergarten 3 ("Neven" [Marigold])					Children's age groups in kindergarten 4 ("Plavi čuperak" [Blonde Cowlick])				
	1 - 2	3	4	5	6	1 - 2	3	4	5	6
	Number of observed children					Number of observed children				
	56	37	55	60	48	47	55	42	41	42
	Annual percentage of affected children					Annual percentage of affected children				
<i>Acute pharyngitis</i>	20.32	14.41	16.97	19.35	14.12	42.91	23.47	31.05	24.05	25.7
<i>Acute tonsillitis</i>										
<i>Acute laryngitis/tracheitis</i>	0.79	1.50	1.01	0.36	0.69	16.12	12.23	11.99	9.82	11.88
<i>Respiratory tract infections</i>	5.52	3.60	2.42	3.58	3.01	13.79	11.39	10.20	9.62	4.75
<i>Influenza</i>	/	/	/	/	/	1.94	1.32	1.07	0.80	1.3
<i>Bronchitis; Acute bronchitis</i>	7.1	6.31	7.68	5.02	4.4	13.01	8.26	8.12	7.41	7.13
<i>Tracheitis and other obstructive pulmonary diseases</i>	/	/	/	/	/	7.57	6.28	4.71	4.01	3.67
<i>Bronchial asthma</i>	0.79	3.30	1.01	0.71	0.46	/	/	/	/	/
<i>Pneumonia</i>						3.5	3.96	2.14	2.40	2.16
<i>Other nose and sinus disorders</i>						/	/	/	/	/
<i>Chronic sinusitis</i>						/	/	/	/	0.43

Table 4. Incidence of respiratory diseases in children attending kindergartens 5 and 6

Respiratory disease name	Children's age groups in kindergarten 5 ("Palčić" [Tom Thumb])					Children's age groups in kindergarten 6 ("Maslačak" [Dandelion])				
	1 - 2	3	4	5	6	1 - 2	3	4	5	6
	Number of observed children					Number of observed children				
	72	67	63	53	56	72	67	63	53	56
	Annual percentage of affected children					Annual percentage of affected children				
<i>Acute pharyngitis</i>	12.81	6.81	5.67	7.11	6.51	21.56	15.62	18.49	8.99	17.84
<i>Acute tonsillitis</i>										
<i>Acute laryngitis/tracheitis</i>	10.03	5.98	4.61	6.49	3.55	2.54	0.64	0.71	0.86	1.2
<i>Respiratory tract infections</i>	0.15	0.83	0.35	0.42	0.39	9.42	5.8	3.4	3.28	4.97
<i>Influenza</i>	5.40	3.16	4.08	4.60	3.55	/	/	/	/	/

<i>Bronchitis; Acute bronchitis</i>	6.94	3.65	2.48	4.60	2.56	4.53	4.35	2.84	1.43	4.80
<i>Tracheitis and other obstructive pulmonary diseases</i>	/	/	0.71	1.46	0.79	0.18	0.48	0.28	0.57	0.17
<i>Bronchial asthma</i>	/	/	/	/	/	0.36	0.81	0.14	0.14	0
<i>Pneumonia</i>	1.54	0.17	0.18	0.42	0.99					
<i>Other nose and sinus disorders</i>	1.7	2.49	1.24	1.05	1.78	0.36	0.16	0.14	0	0
<i>Chronic sinusitis</i>	3.70	1.99	1.95	1.46	2.56	0.18				

The results of the incidence of respiratory diseases indicate that the highest percentage of affected children was observed in kindergartens 4 and 1, ranging from 37.44% to 39.48%. The two kindergartens are located in areas with the highest predicted mean annual carbon monoxide concentration of 7.8 mg/m³. The lowest percentage of affected children was determined in kindergarten 5 (25.79%), with the predicted mean annual carbon monoxide concentration of 4.8 mg/m³. However, proportionality cannot be confirmed through comparison of the mean annual concentrations and the percentage of children suffering from a respiratory disease, as indicated by the case of kindergarten 3, which had a predicted mean annual carbon monoxide concentration of 2.93 mg/m³ and as many as 29.08% of affected children (Figure 3). Nevertheless, the analysis of the other five kindergartens suggests a direct cause-and-effect relationship between the incidence of respiratory diseases and the concentrations to which preschool children are exposed (Figure 3). The discrepancy between kindergarten 3 and the other kindergartens can be explained by the fact that the incidence of respiratory diseases in preschool children also depends on the number of days in a year with high carbon monoxide concentrations. The location of kindergarten 3 is characterized by the appearance of local circulation zones and prolonged periods of pollutant retention. In order to establish the causality between health risk and air pollution, further research should focus on the impact of daily concentrations on the incidence of diseases.

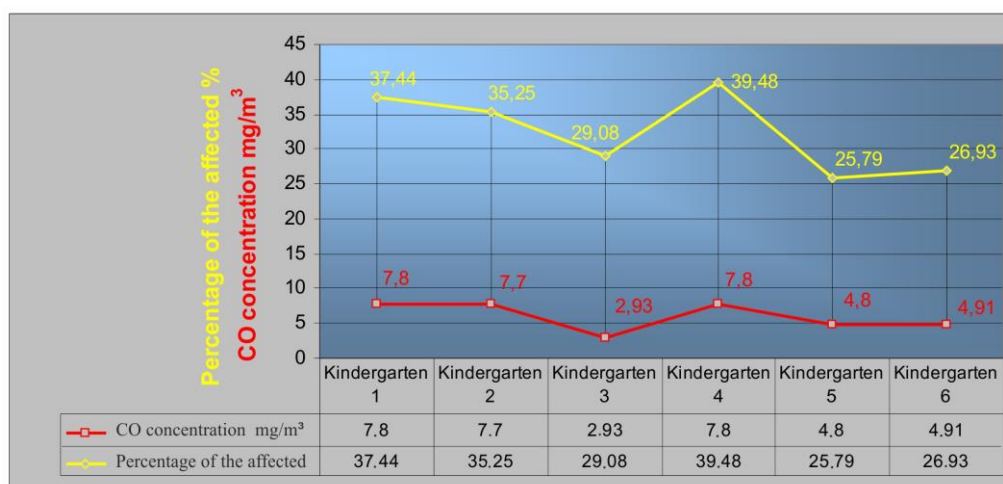

Fig. 3. Mean annual carbon monoxide concentrations and percentage of respiratory disease incidence in the exposed population aged 1 to 6 at the analyzed kindergartens

CONCLUSION

The presented results and their analysis unequivocally lead to the following conclusions:

- The trend line of children suffering from a respiratory disease and the trend line of mean annual carbon monoxide concentrations in external ambient air are correlated, which confirms the causality between air pollution and the incidence of respiratory diseases in the analyzed exposed subpopulation.

- The analysis of respiratory disease incidence in the observed subpopulation (preschool children) showed that the highest percentage of affected children (39.48%) was found in the areas with the highest mean annual carbon monoxide concentrations of 7.8 mg/m³.
- The results of the analysis indicate the possibility of a cause-and-effect relationship increased carbon monoxide concentrations in external ambient air and the incidence of respiratory diseases in preschool children. However, it is impossible to establish direct proportionality between mean annual carbon monoxide concentrations and the incidence of respiratory diseases, because such incidence also depends on the number of days in a year with high pollutant concentrations. Therefore, it is necessary to continuously monitor pollutant concentrations in ambient air and the future incidence of respiratory diseases.
- Development of a network and system for the monitoring of urban ambient air quality significantly helps researchers draw conclusions regarding the causality between air pollution and respiratory diseases. Such a network/system is also an important prerequisite for the prevention of respiratory diseases in the analyzed exposed subpopulation of preschool children.

ACKNOWLEDGMENTS

This study is financed by the Serbian Ministry of Education, Science and Technological Development.

REFERENCES

- [1] WHO, Burden of disease from Household Air Pollution for 2012 - Summary of results, 2014.
- [2] WHO, Ambient air pollution - A global assessment of exposure and burden of disease, 2016.
- [3] World Bank and Institute for Health Metrics and Evaluation, The Cost of Air Pollution: Strengthening the Economic Case for Action. Washington, DC: World Bank, 2016.
- [4] MacIntyre, EA., Gehring, U., Mölter, A., Fuentes, E., Klümper, C., Krämer, U., Quass, U., Hoffmann, B., Gascon, M., Brunekreef, B., Koppelman, GH., Beelen, R., Hoek, G., Birk, M., de Jongste, JC., Smit, HA., Cyrys, J., Gruzjeva, O., Korek, M., Bergström, A., Agius, RM., de Vocht, F., Simpson, A., Porta, D., Forastiere, F., Badaloni, C., Cesaroni, G., Esplugues, A., Fernández-Somoano, A., Lerxundi, A., Sunyer, J., Cirach, M., Nieuwenhuijsen, MJ., Pershagen, G., Heinrich, J., Air pollution and respiratory infections during early childhood: an analysis of 10 European birth cohorts within the ESCAPE project. *Environmental Health Perspectives*, 122 (1), 107–113, 2014.
- [5] Lyndsey, D., Mitchel K., Flanders, D., Mulholland, J., Tolbert, P., Strickland, M., Air Pollution and Acute Respiratory Infections Among Children 0–4 Years of Age: An 18-Year Time-Series Study, *American Journal of Epidemiology*, 180 (10), 968–977, 2014.
- [6] Đorđević, A., : Kauzalna analiza kvaliteta vazduha i zdravstvenog rizika od aerozagađenja, Doktorska disertacija, UDK: 504.064, Fakultet zaštite na radu u Nišu, Univerzitet u Nišu, (str. 293), 2010.
- [7] WHO, Fact Sheet 206: Bronchial asthma (<http://www.who.int/mediacentre/factsheets/fs206/en/>) pristupljeno 11. 11. 2017.
- [8] Royal College of Physicians, Every breath we take: the lifelong impact of air pollution. Report of a working party. London, RCP, 2016.

MODEL FOR QUANTIFICATION OF ENVIRONMENTAL IMPACT OF TEXTILE PRODUCTS WITHIN WEBSHOPS

Nemanja Stipić¹, Jürgen Seibold¹

¹German Institutes of Textile and Fiber Research, Denkendorf, Germany

e-mail: nemanja.stipic@ditf.de

Abstract: This paper presents generic Life Cycle Assessment (LCA) model which could be used for quantification of environmental impact (e.g. greenhouse gasses, virtual water) of various textile products available on the market. The model brings transparency into the complete textile production chain, differentiating between specific production processes like extraction of raw materials, spinning, weaving, knitting and finishing. The model was also used to create an overview of the environmental impact values of ten commonly used textile material groups.

Second part of this paper considers the shipping phase between seller and customer when buying in a webshop, whereby three common scenarios were analyzed. As a crucial indicator in this phase, the product's return rate was identified (e.g. product does not fit, and customer sends it back to seller). By reducing return rate, a reduction in material, energy, resources and waste could be achieved, which could significantly decrease environmental impact of the textile industry.

Key words: textiles, LCA modelling, environmental impact, webshop

INTRODUCTION

The fashion industry has changed rapidly in recent years with the increased prevalence of fast fashion, impacting the environment. Clothing is produced on shorter timeframes with new designs appearing every few weeks to satisfy demand for the latest trends, but with this comes increased consumption and more waste. Besides, textile production is one of the most polluting industries, causing 1.2 billion tonnes of CO₂ emissions per year, which is more emissions than international flights and maritime shipping [1,2]. Over 60% of textiles are used in the clothing industry and a large proportion of clothing manufacturing occurs in China and India, countries which rely on coal-fuelled power plants, increasing the footprint of each garment. It has been stated that around 5% of total global emissions come from the fashion industry [1,3]. In the time of climate change customers want more transparency considering also which environmental impact lies behind their product. Nowadays, this information is rarely available and when individuals are considering how to minimize their carbon footprint, thoughts often turn to air travel with its large emissions, while some small day-to-day changes may be overlooked [1].

This paper will present a model which can be used for quantification of environmental impact of various textile products on the market. It will bring transparency in the whole production chain, whereby it will be possible to detect which production phases are contributing the most. This model could be implemented into existing webshops and it could approximately calculate the CO₂ emission and amount of virtual water used for the creation of almost every textile product.

Afterwards the shipping phase between seller and customer will be analyzed too. The goal is to calculate environmental impact in this phase and to compare the results with the production phase. Here, the return scenario will also be included in which the customer is not satisfied with the product (e.g. product does not fit) and returns it back to the seller. Two key parameters in this phase, such as return rates and waste, will be considered and their connection to total environmental impact of textile industry in case of Germany will be analyzed.

MATERIALS AND METHODS

The Life Cycle Assessment (LCA) was used as a method for the calculation of ecological impacts. This standardized method (ISO 14040/44: 2006) [4,5] can quantify environmental pollution using various environmental impact indicators (e.g. global warming potential, acidification potential, eutrophication potential, ozone depletion potential, ecological toxicity ...). This paper will however focus on global warming potential (GWP) and amount of water needed for the production of textiles.

Because this water usage is taking place in the production phase, customers don't see it, and that's why it is also called the virtual water.

GWP is caused by greenhouse gases (CO₂, CH₄, N₂O, CFCs, PFCs ...) which lead to the greenhouse effect. This effect is described by the unit kg CO₂-equivalents and shows the mean warming effect of the Earth's atmosphere over a certain period of time (usually 100 years). As a method for the Life Cycle Impact Assessment (LCIA), the IPCC 2013 (Intergovernmental Panel on Climate Change) method was used. This method searches for all emissions (greenhouse gases) within the framework of an analyzed model. This step is also known as classification. Furthermore all greenhouse gases are multiplied by a certain characterization factor. For example, the characterization factor for CO₂ is 1 while the characterization factor for CH₄ is 30.5 according to IPCC 2013 [6]. This means that CH₄ is 30.5 times more effective greenhouse gas than CO₂. This step is also known as characterization. Finally all classified and characterized emissions are added to calculate the total GWP within a defined model (kg CO₂-eq).

Virtual water describes the amount of water that was used to manufacture a product. In Germany, around 124 liters of water are used per inhabitant per day, but Germany also imports a lot of indirect (virtual) water from abroad which is embedded in products. That being said 4,000 - 5,000 liters of virtual water is used daily by average inhabitant in Germany [7]. Looking at the individual products, manufacturing a microchip consumes 32 liters, and when making one kilogram of beef consumes 15,000 liters [8]. This huge water amount for the beef production could be further explained: When producing beef, not only the use of drinking water for the animals must be taken into account, but also the natural precipitation and irrigation for fields and meadows that provide the feed for the animals. Compared to the GWP, no LCIA method (such as IPCC 2013) is required for the virtual water because the water is only the result of the life cycle inventory (LCI). Water from various sources (river, lake, groundwater ...) is equally considered and added. In addition, large amounts of water are used to generate electricity for the turbine and cooling. However, these water fractions are released into the river unpolluted after use. This phenomenon is known as "water borrowing" [9] and therefore this water amount is not considered as a part of the final product.

RESULTS

Model for the calculation of environmental impact of textile products in the production phase

The goal of this part was to develop a LCA model that will calculate the environmental impacts (GWP and virtual water) for various textile products available on the market. The functional unit is 1 kg of different textile materials, and this amount can further be multiplied with the specific weight of textile products in order to get specific product values. The model was divided into three different phases (extraction of raw materials, spinning & weaving/knitting and finishing) in order to support the identification of hotspots during production.

The Model was created with help of the LCA software Umberto LCA+, which was developed by ifu Hamburg. Figure 1 shows the model in which the processes are shown as squares, and intermediate products as well as inputs and outputs are shown as circles. All processes that are marked with the small yellow lock in the upper right corner are taken from the world's largest and the most well-known life cycle inventory database, ecoinvent 3.6 [10]. These processes consume resources and cause emissions which form the basis for calculation of the above-mentioned environmental impact categories. The remaining processes (without the little yellow lock in the upper right corner) are auxiliary processes which either serve to support the modeling or to request the energy requirements of certain manufacturing processes (e.g. spinning, weaving, knitting, pretreatment or finishing). The energy requirement of these processes was taken from the literature [11] and was modeled with parameters to support the calculation of different textile materials. The model is visualized with the help of a Sankey diagram. These diagrams are a graphic representation of mass or other flows in which the width of the arrows is proportional to the flow rate.

Figure 1 shows the calculated GWP for 1 kg of the exemplary material group which consists of 50% cotton and 50% polyester. This material is also woven and made of staple fibers without twisting, with an average yarn thickness of 150 dtex. The calculated GWP in this case is 15.97 kg CO₂-eq, whereby

the highest contribution comes from the weaving (4.17 kg CO₂-eq) and spinning process (3.25 kg CO₂-eq). The same model also supports the calculation of virtual water.

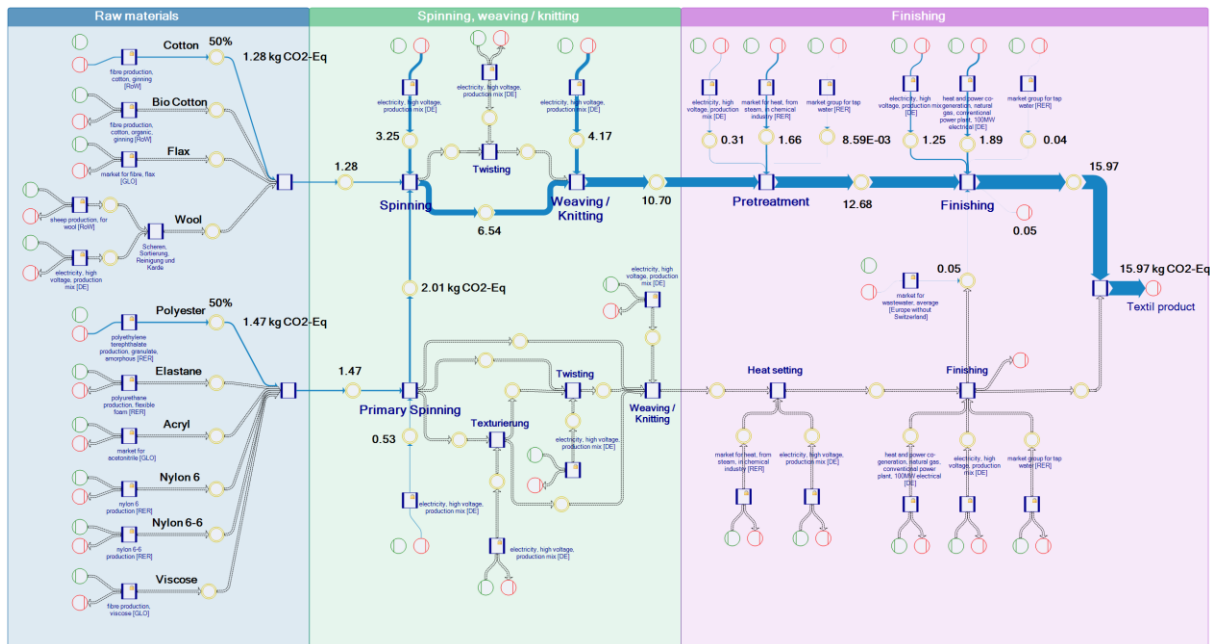

Fig. 1. LCA Modell: Calculation of environmental impacts (15.97 kg CO₂-eq and 1,000 liter water) for the exemplary material group (1kg, cotton 50%, polyester 50%, weaving with the yarn thickness of 150 dtex), GWP view

The first phase “Raw materials” consists only ofecoinvent 3.6 processes and in this phase the results are calculated without cut-off. This phase also includes the necessary transports and infrastructure for the production of the raw materials as described by ecoinvent [10].

For the phase “Spinning, weaving / knitting” the cut-off of 1% is considered. This means that in this phase only the electricity is a relevant resource, with a total environmental impact of at least 99%. Other resources and emissions in this phase cause less than 1% of the total environmental impact and can therefore be neglected. Transports are also not taken into account in this phase. The main focus of this phase is the electricity demand for spinning, weaving and knitting, which changes with different yarn thickness (dtex).

The “Finishing” phase is the last step in textile production. The specific resources (electricity, gas, water and steam) are taken from the literature [11]. In order to avoid the cut-off, the remaining emissions from the refining process were taken from the public data, which represent the best available technologies in the Netherlands [12]. In this phase, the transport was also neglected. Although the transport is only considered in the first phase, it can be estimated that the transport only makes a relatively low contribution to the environmental impact in comparison with the other processes in the process chain. For example, shipping from China causes an additional 0.16 kg CO₂-eq per kilogram of fabric [11].

Environmental impact of specific material groups

In order to calculate environmental impacts of different material groups, the following parameters are taken into account:

- Different materials and material mixtures (conventional cotton CO, organic cotton CO Bio, polyester PES, elastane EL, flax, wool, acryl, nylon 6, nylon 6-6 PA and viscose CV);
- Different manufacturing variants (knitting / weaving, staple fiber yarn line / filament yarn line, with twists / without twists, with texturing / without texturing);
- Yarn thickness (in dtex = decitex = 0.1 tex, whereby 1 dtex is equal to 1 g/10 km).

The next step was to select the different material groups and to calculate their environmental impacts. Table 1 shows that a total of ten material groups were selected (roman numerals), with some

additional specifications representing mostly different manufacturing variants and yarn thickness (a, b, c ...). The GWP and virtual water amount is calculated for 1 kg of every material group. These results can be further multiplied with the specific weight of various textile products in order to get specific product results (GWP and water for each textile product). Furthermore, other frequent material groups could also be calculated and added to the table.

Table 1. Environmental impact of 1 kg of different material groups

Material group	Production variant	Yarn thickness (dtex)	Materials	GWP (kg CO ₂ -eq)	Water (Liter)
I, a	Knitting	70	100% CO	15.19	1760
I, b	Knitting	150	100% CO	11.26	1740
I, c	Knitting	250	100% CO	9.89	1740
I, d	Weaving	70	100% CO	23.73	1810
I, e	Weaving	150	100% CO	15.25	1760
I, f	Weaving	250	100% CO	12.28	1750
II, a	Knitting	150	100% CO Bio	9.27	190
II, b	Weaving	150	100% CO Bio	13.26	220
III, a	Knitting	150	100% PES	12.27	210
III, b	Weaving	150	100% PES	16.70	230
IV	Knitting	150	95% CO, 5% EL	11.45	1670
V	Knitting	150	95% PES, 5% EL	12.84	220
VI, a	Knitting	150	100% CV	13.27	400
VI, b	Weaving	150	100% CV	17.26	420
VII, a	Knitting	150	100% PA	18.01	370
VII, b	Weaving	150	100% PA	22.00	390
VIII, a	Knitting	150	100% Acryl	13.99	210
VIII, b	Weaving	150	100% Acryl	17.98	230
IX	Knitting	250	100% Wool	52.37	610
X	Weaving	150	50% CO, 50% PES	15.97	1000

Customer related environmental impact caused by returns in a webshop

After explaining the LCA model that can calculate environmental impact of various textile products in the previous chapter, this part will focus on shipping phase when buying cloths in a webshop. Additional aspects like warehouse, packaging and transport to customer were added, as well as return transport, processing and disposal in cases where customer sends his product back to the seller. Figure 2 shows the second LCA model whereby four phases can be identified as four columns in the model (manufacturing, warehouse, transport and customer). The first LCA model is integrated in the manufacturing phase. No transport is taken into account between the manufacture and the warehouse. The remaining three phases (warehouse, transport and customer) contain all the relevant parameters that could occur during an online ordering. As with the first LCA model, the basis for calculating the environmental impacts are ecoinvent 3.6 processes. These processes are marked with the small yellow lock in the upper right corner.

In order to support the calculation of different scenarios when buying in a web shop, the second LCA model was also developed with the help of parameters. These parameters are: amount of articles that customer buys or returns, different packaging materials and their percentage mass (e.g. paper 10% and plastic 2%), different transportation distances (e.g. 150 km), various processing scenarios with waste content and electricity demand (e.g. 1 kWh / kg electricity for washing, drying and ironing), different "end of processing" scenarios (A goods, B goods or waste). Overall, three scenarios were analyzed. Scenario 1 represents the case where the customer orders and buys the product. This is the best scenario because there is no unnecessary effort through returning or processing of product. In addition to manufacturing, only a small additional environmental impact is added by packaging and transportation of the product. In scenario 2, the customer is not satisfied with the product (e.g. it does

not fit) and sends it back to the seller. In this scenario, the product can be used again as A or B goods. Because the product's lifecycle is not over, a new product does not need to be manufactured. This scenario contains a bit bigger environmental impact than scenario 1, caused by additional return transport and processing. In scenario 3, the product is sent back to the seller like in scenario 2, but it has to be discarded (due to damage or end of season). In this case the product's life cycle has ended and a new product must be created causing a significant amount of environmental impact in the manufacturing phase. Therefore, scenario 3 is the worst scenario from ecological perspective and it causes significantly more environmental burden than the other two scenarios.

As an exemplary product, a 250g T-shirt produced with material group X (50% CO, 50% PES, weaving, 150 dtex) has been chosen, causing a total of 3.99 kg CO₂-eq and 250 liter water in the manufacturing phase (the first LCA model). Finally, figure 2 shows the second LCA model in which this T-Shirt has been packed and transported to the customer causing some additional CO₂ emissions. In figure 2, the scenario 2 has been chosen where the customer sends the T-shirt back to the seller and therefore additional return transport and processing were required, which caused some additional CO₂ emissions. However in this scenario the T-shirt was not damaged and it was returned to the warehouse as A goods. In this case the T-Shirt which originally caused 3.99 kg CO₂-eq in the manufacturing phase caused additional emissions in the framework of scenario 2, making the total CO₂ emissions increasing by 0.37 kg CO₂-eq for only one T-shirt. Because the T-shirt was not sold, it can be said that these additional emissions represent an unnecessary environmental impact.

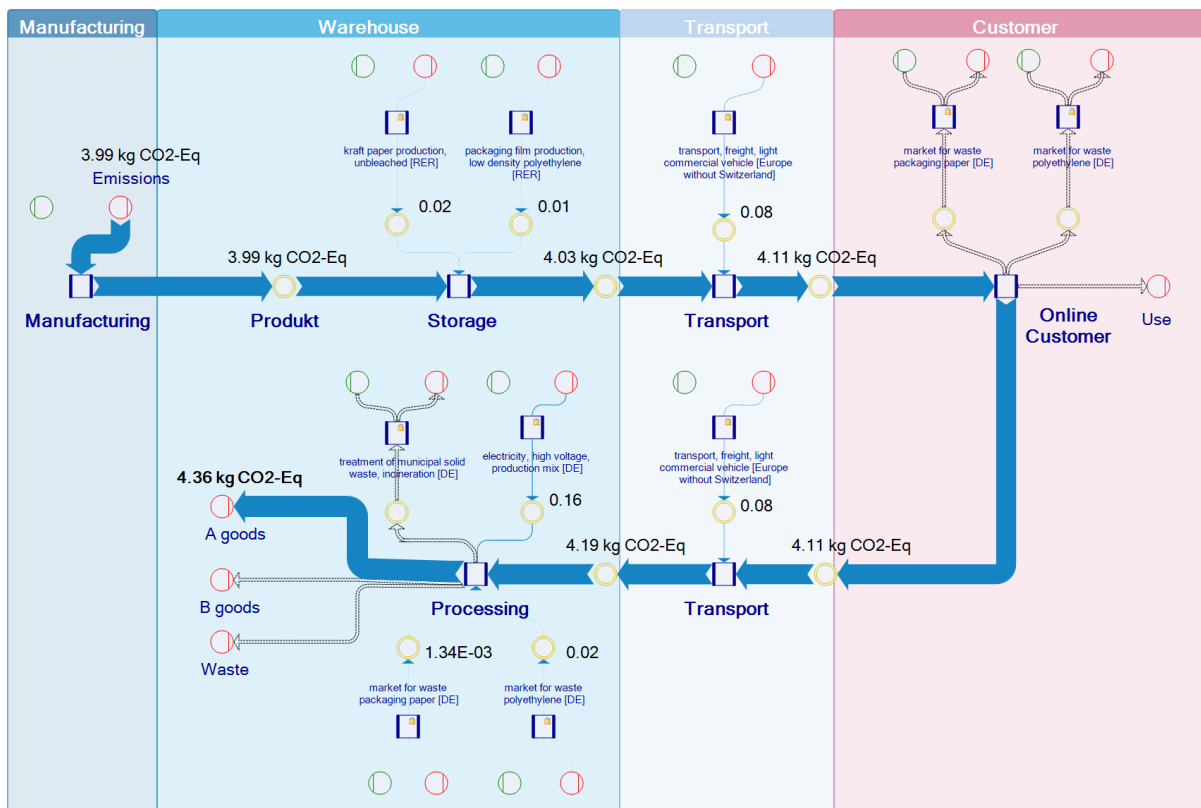

Fig. 2. Scenario 2: Attempted delivery of a T-shirt, GWP view

DISCUSSION

Assuming that newly manufactured clothing consists of different fiber mixtures, the following average fiber composition worldwide was used: 64% synthetics (polyester), 24% cotton, 6% natural fibers and 6% cellulosic fibers [13]. For this average fiber mixture, it was calculated in the first LCA model that 1 kg of average clothing causes approx. 16 kg of CO₂-eq. In addition, the medium yarn thickness of 150 dtex was assumed with woven fabrics. However, this value can vary very widely, for example between 5 and 50 kg CO₂-eq for 1 kg of the above-mentioned fiber mixture. The four main reasons for this are:

- The yarn thickness of the fabrics produced annually worldwide is not considered in the literature. Table 1 clearly shows that the finer yarns consume more electricity. For example, 1 kg of coarse (250 dtex) cotton knitted fabrics causes 9.89 kg of CO₂-eq, but when it comes to fine (70 dtex) knitted fabrics, this value increases to 15.19 kg of CO₂-eq. This phenomenon applies to all considered materials from Table 1.
- There is hardly any differentiation between woven and knitted fabrics in the literature. As Table 1 shows, the CO₂ emissions increase up to 12.28 kg CO₂-eq for coarse (250 dtex) cotton fabrics and up to 23.73 kg CO₂-eq for fine (70 dtex) fabrics respectively if weaving is used instead of knitting.
- The GWP value of the electricity mix used can also vary greatly. In the production phase the German electricity mix was used, which according to the ecoinvent 3.6 database causes 0.63 kg CO₂-eq per kWh. For renewables, this number can drop dramatically, but it can also significantly increase for dirty technologies. The country-specific differentiation is also very significant. When using the Chinese or Indian electricity mix, the GWP can increase by up to 50-75% per kWh. For example, the above mentioned GWP value of 16 kg CO₂-eq was calculated for the yarn thickness of 150 dtex and with weaving process. Combined with the additional processes a total of 15.56 kWh was used for the manufacturing of 1 kg of such mixed textile. If using German electricity mix, this energy consumption causes 9.8 kg CO₂-eq, but if however the Swiss electricity mix were used (GWP = 0.11 kg CO₂-eq per kWh), only 1.71 kg CO₂-eq would arise for electricity consumption. On the other hand, if Indian electricity from coal production (GWP = 1.4 kg CO₂-eq per kWh) were considered, the CO₂ emissions would increase up to 21.78 kg CO₂-eq only due to electricity. If the fabric thickness is fine (70 dtex), this value would increase up to 40.77 kg CO₂-eq.
- The technologies used in the finishing phase can vary drastically. Different literature sources therefore report very different energy requirements, chemicals and water quantities. In order to take a closer look at this phase, the specific textile products have to be analyzed and specific technologies have to be considered. Country-specific differentiation also plays an important role here.

Likewise, for the above-mentioned average fiber mixture it was calculated that 1 kg of such clothing consumes approx. 670 liters of water in the manufacturing phase. The value can also vary widely. The three main reasons for this are:

- Consideration of different water resources: Is only blue water from surface (river and lake) and groundwater considered, or also green water from rain? The LCA database ecoinvent 3.6 used in the model only considers blue water. Typical values for green water per 1 kg of cotton are between 0 m³ (Egypt) and 15 m³ (India) [14], depending on the region.
- The proportion of blue water for the manufacture of cotton can also vary greatly in different countries. Typical values for blue water per 1 kg of cotton are between 0.1 m³ (Brazil) and 13 m³ (Turkmenistan) [14], depending on the region. The global average is 1240 liters (1.24 m³) [15], or 1550 liters according ecoinvent 3.6 Database [10].
- The water requirement in the finishing phase is also very different depending on the country and the technology used. In this model, 135 liters water was taken into account in the finishing phase. Literature shows that water requirements in this phase could vary between 25 and 2,000 liters water per kg of textile [11].

The following calculations are based on 16 kg CO₂-eq and 670 liters of water per kg of average clothing produced. Assuming that an average of 2.1 kg of clothing is bought online per year and per person [16,17], this results in a total of 33.6 kg CO₂-eq and consumes 1407 liters of water. As explained above, more conservative consumption levels were used as a basis. In addition, a small amount of emissions must be added for packaging and transport. If the product is purchased, this portion is not considered to be unnecessary pollution, but if the product is returned, this portion should be viewed as unnecessary environmental pollution, combined with the return transport and processing. Table 2 shows which unnecessary environmental pollution could be avoided if the return rate is reduced. In addition to variation of return rates, two scenarios for reusability are also considered. In one scenario, the returned goods are reused and in the other scenario 30% of the returned goods are disposed of.

With a usual return rate of 50% and the assumption that the returned articles can be used again, 3.07 kg CO₂-eq are unnecessarily caused and 10 liters of water are used due to packaging, transportation and processing. If 30% of the returned goods have to be disposed, the corresponding amount of new goods will be produced, which will unnecessarily cause 13.48 kg CO₂-eq and consumes 433 liters of water. This significantly increases the unnecessary environmental impact. Table 2 also shows the unnecessary environmental burden for different return rates.

Table 2. Unnecessary environmental impact for different return rates (RR) both with and without waste scenario

2.1 kg Clothing (64% PES, 24% CO, 6% Flax, 6% CV)	Unnecessary GWP (kg CO ₂ -eq)		Unnecessary Water (Liter)	
	100% reusable	with 30% waste	100% reusable	with 30% waste
RR 50%	3.07	13.48	10.0	433
RR 40%	2.05	8.98	7.0	289
RR 30%	1.32	5.78	4.0	186
RR 20%	0.77	3.37	2.5	108
RR 10%	0.34	1.50	1.0	48

Furthermore, figure 3 shows how the unnecessary environmental impact decreases drastically with reduced return rates. The numbers from table 2 (with 30% waste) have been scaled up with the number of residents in Germany (83 million).

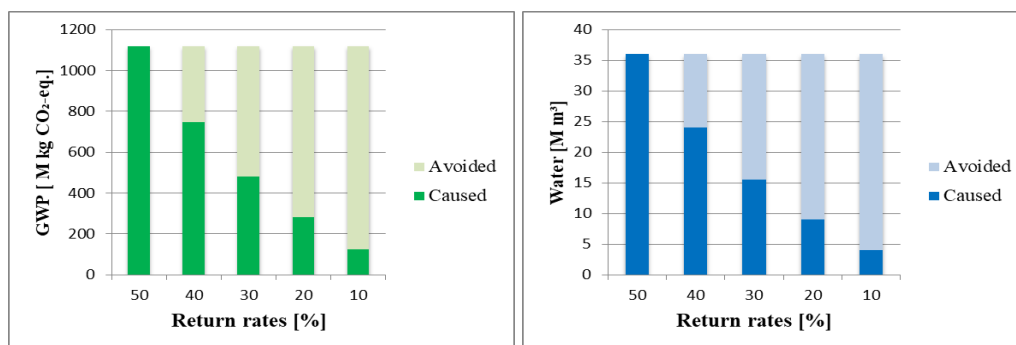

Fig. 3. GWP and water savings with reduced return rates, annual scenario for Germany

CONCLUSION

The ecological assessment has shown that the environmental impact is mostly caused by the following three aspects: the manufacturing phase, return rate and waste percentage of returned articles. The environmental impact in the manufacturing phase has a significant contribution, and in the discussion chapter it was concluded that 1 kg of average clothing (64% synthetics, 24% cotton, 6% natural fibers and 6% cellulosic fibers [13]) can cause between 5 and 50 kg CO₂-eq and can use very different amount of water. However the goal of this paper was not to prevent customers from buying clothes or to favor certain products compared to others. Therefore it could not be stated that this amount of environmental pollution is unnecessarily caused. The goal of this paper was to calculate the unnecessary environmental impact and therefore only the article return rate and waste percentage of returned articles were considered as the critical parameters.

That being said, lots of unnecessary environmental impact could be avoided by reducing the return rates, which would also cause less waste of returned articles. Looking at the return rate in online retailing in the clothing industry, it is between 25 and 50 percent, depending on product group. Whereby, 86% of the returns in online clothing retailing can be traced back to fit problems [18,19]. After detailed analysis of Figure 3, it can be concluded that the GWP and water increases disproportionately when the return rate increases. In order to achieve the same absolute savings potential with a 1% reduction within the 50% return rate, a 4% reduction must be achieved within the 20% return rate. This means that the sensitivity is significantly greater with higher return rates, and the focus should be oriented to the products that have the higher return rates.

Future developments must therefore support an optimal individual fit in order to further reduce the return rate. With the help of modern tools for digitalization and simulation, fit could be optimized and return rates, as well as waste would be minimized, resulting in great environmental savings. This can only be achieved through customized production, ideally with sustainable production in Europe.

ACKNOWLEDGMENT



This paper is a result of the research within the project AZ 34611 [20] supported by the German Federal Environmental Foundation (Deutsche Bundesstiftung Umwelt – DBU).

REFERENCES

- [1] The price of fast fashion. *Nature Clim Change* 8, 1 (2018); <https://doi.org/10.1038/s41558-017-0058-9>
- [2] A New Textiles Economy: Redesigning Fashion's Future (Ellen MacArthur Foundation, 2017).
- [3] Bauck, W. The fashion industry emits as much greenhouse gas as all of Russia. *Fashionista* (22 September 2017); <http://go.nature.com/2Cj3ndP>
- [4] International Organization for Standardization (ISO) 14040:2006: Environmental management — Life cycle assessment — Principles and framework: <https://www.iso.org/standard/37456.html>
- [5] International Organization for Standardization (ISO) 14044:2006: Environmental management — Life cycle assessment — Requirements and guidelines: <https://www.iso.org/standard/38498.html>
- [6] Intergovernmental Panel on Climate Change (IPCC), *Climate Change 2013: The Physical Science Basis*, Cambridge, United Kingdom and New York, NY, USA, retrieved from: <https://www.ipcc.ch/report/ar5/wg1/>
- [7] Wagner, B. (2018). Wasser sparen durch die Ernährung: <https://www.wir-essen-gesund.de/wasser-sparen-ernaehrung/>
- [8] Hoekstra, A. (2003). Virtual water trade: <https://www.waterfootprint.org/media/downloads/Report12.pdf>
- [9] Flury, K., Jungbluth, N., Frischknecht, R., & I. M. (2012). Recommendation for Life Cycle Inventory Analysis for Water Use and Consumption. Working paper.
- [10] ecoinvent Centre (2019), ecoinvent data v3.6, ecoinvent reports No. 1-25. Swiss Centre for Life Cycle Inventories, Zurich, Switzerland, retrieved from: <https://www.ecoinvent.org/>
- [11] Velden, N. M., Patel, M. K., & Vogtländer, J. G. (2013). LCA Benchmarking study on textiles made of cotton, polyester, nylon, acryl, or elastane.
- [12] Netherlands, G. o. (2020). De Nederlandse emissies naar lucht, water en bodem; von Pollutant Release and Transfer Register: <http://www.emissieregistratie.nl/erpubliek/bumper.nl.aspx>
- [13] Quantis. (2018). Measuring Fashion, Insights from the Environmental Impact of the Global Apparel and Footwear Industries study.
- [14] Chapagain, A., Hoekstra, A., Savenije, H., & Gautam, R. (2015). The Water Footprint of Cotton Consumption. *Research Report Series*, 18, page. 18.
- [15] Huges, K. (2018). A Force for Good for Cotton?; International Cotton Advisory Committee.
- [16] TrueFit. (2017): <https://www.truefit.com/en/wp-state-of-returns>
- [17] Steinlein, C. (01. 12 2009). Nachhaltigkeit Kleidung: https://www.focus.de/wissen/klima/klimapolitik/tid-16518/nachhaltigkeit-kleidung_aid_461058.html; focus.de
- [18] Rösch, B. (2013). Versender sagen Retouren den Kampf an. *TextilWirtschaft*, 29, page. 26-29.
- [19] Pur, S. (2013). Retourenmanagement im Online-Handel – Das Beste daraus machen. Regensburg: ibi research an der Universität Regensburg GmbH
- [20] Passend bestellen dank virtueller Kleideranprobe (2018) – DBU Förderung: https://www.dbu.de/123artikel38075_2442.html?fbclid=IwAR1DIMy_UbNxvUFN5SVkSLI_Q3KDDQYk1sXDnwmBAIhkmEQID6jiCEW0Htl

SYNTHESIS AND IMMOBILIZATION OF ZnO NANOPARTICLES DOPED BY WO₃ ON GLASS BED FOR DIAZINON REMOVAL FROM WATER

Afshin Maleki¹, Farzaneh Moradi¹, Reza Rezaee¹, Behzad Shahmoradi¹

¹Environmental Health Research Center, Research Institute for Health Development, Kurdistan
University of Medical Sciences, Sanandaj, Iran.
e-mail: maleki43@yahoo.com

Abstract: Agricultural activities, in which different pesticides are used, can highly contaminate water bodies. Diazinon is an organophosphate insecticide, which has extensively been applied all around the world to control damaging crops, and many other agricultural products. Hence, the suitable treatment of wastewaters containing this insecticide is of great importance. In the current research, the tungsten oxide doped ZnO nanoparticles were synthesized using a hydrothermal procedure to degrade diazinon. The molar percentage of tungsten oxide for doping was 1%. An increase in pH to 7 caused the removal efficiency to enhance; thus, this value was selected as the optimum pH. When the initial content of the insecticide was raised between 10 and 200 mg/l, the removal efficiency declined between 85 and 33%. However, the increase of catalyst dosage (2-10 mg/cm²) led to a rise in efficiency (63-78%). The observations of the present study illustrated that, under the optimum conditions, the nano-photocatalytic method: zinc oxide doped by tungsten oxide was capable of degrading diazinon from aqueous solutions.

Key words: diazinon, nanophotocatalyst, operating parameters, WO₃ doped ZnO, consolidation

INTRODUCTION

Diazinon, which is an organophosphorus insecticide, has commonly been employed to kill mites, insects and nematodes. This compound considered a relatively hazardous substance (class II) according to the World Health Organization (WHO) [1, 2]. It should be pointed that even low levels of this insecticide at 350 ng/l can threaten aquatic ecosystem [3, 4]. The literature review revealed that 90-444 mg/kg of diazinon is lethal dose range for humans [3, 5, 6]. Also, the 0.6 µg/l of diazinon in drinking water is the maximum level of this insecticide, which is not dangerous for human health, according to the United States Environmental Protection Agency (USEPA) [7].

A few processes have been introduced to degrade diazinon from aqueous environments. The photocatalytic degradation process, in which the oxides of semiconductor metals are used, has been utilized as a suitable method in environmental approaches [8, 9]. Several metal oxides like titanium, tungsten oxide, zinc oxide, and so on have been applied as an active photocatalyst for the photocatalytic decomposition of environmental contaminants [10, 11]. ZnO and TiO₂ are two photocatalysts which have commonly been utilized because of their unique plus factors like high light sensitivity, as well as wide-bandgap energy [12, 13]. Nonetheless, since the band gap energy of ZnO is high (3.37 eV), the photocatalytic performance of it is restricted to the ultraviolet light [14, 15]. Besides, another disadvantage of ZnO is the fast recombination of the electron/hole cavity production, agglomeration, and low dispersion [16-18]. It should be pointed out that if the dopants and surface modifiers are used to change the structure of ZnO, the performance of it can be enhanced. Thus, the application of a suitable dopant that has narrow bandgap energy can effectively be used photocatalytic removal of various contaminants [19, 20]. Tungsten oxide (WO₃) can helpfully been used for doping. Because the bandgap energy of WO₃ is 2.8 eV, the zinc oxide bed can be activated by this material. The semiconductor of tungsten oxide benefiting from a narrow bandgap energy can efficiently be activated under sunlight illumination and perform like a potent photocatalyst [21]. Moreover, the stability of this photocatalyst is very high and can effectively decompose several pollutants. Hence, the prime objective of the current research was to dope the synthesized ZnO nanoparticles using WO₃ and then the produced photocatalyst

was immobilized on glass. Furthermore, the impacts of reaction time, pH, initial content and catalyst dosage were studied.

MATERIAL AND METHODS

WO₃ and diazinon were bought from Sigma-Aldrich (USA) and other materials were prepared from Merck Company (Germany). It should be pointed out that the materials applied in this study were of laboratory grade. All the batch experiments were carried out in a Plexiglas reactor. And, five 6-Watt ultraviolet lamps (length 21 cm) (Philips Co., the Netherlands) were employed to supply the energy. In this study, a hydrothermal procedure was exerted to synthesize the ZnO nanoparticles. First, in a 10-mL Teflon liner, the following conditions were prepared: initial ZnO concentration: 2 N, WO₃ concentration 1%. Next, 10 mL of 1-N NaOH and 0.5 mL of the surfactant were added to the solution, and then was autoclaved (120 °C) for 12 h. Afterwards, double distilled water was used to wash well and it was dried at laboratory temperature [17]. Then, the nanoparticles were immobilized on sandblasted glass. Then, a few contents of WO₃ were used to dope the nanoparticles and were expanded on glass. Finally, an oven was applied to dry the glass (100 °C) [22, 23]. In the present study, the key variables effective in diazinon degradation such as solution pH of 5, 7, 9 and 11, content of the nanoparticles per unit area of the glass of 2, 6 and 10 mg/cm², insecticide content of 10, 20, 50, 100 and 200 mg/l, and reaction time of 20, 10, 30, 45, 60, 90, 120 and 180 min). Also, diazinon residuals were detected by means of standard methods.

RESULTS AND DISCUSSION

The SEM images of the pure and doped by a few concentrations of WO₃-ZnO nanoparticles have been presented in Figure 1a. As can clearly be seen, the ZnO nanoparticles have been properly synthesized and had a hexagonal structure. For the assessment of the nanoparticles' crystalline structure and purity, the XRD pattern was applied (Figure 1b). The findings of doping the ZnO nanoparticles with some concentrations of WO₃ displayed the three major peaks (100), (002) and (101), attributed to the crystalline structure of the ZnO nanoparticles on the Miller index. According to the index, as well as the SEM images, in the XRD analysis, the hexagonal nanoparticle was proved. The FTIR spectra of the pure and doped nanoparticles have been shown in Figure 1c. In the area of 469 1/cm, a strong bond was seen confirming the stretching frequency of the ZnO nanoparticles [24]. And, at 870 1/cm, the absorption band was seen, which is ascribed to the W-O-W to the n(O-O) and n(W-O-W) stretching of the bridging oxygen inside WO₃. Also, at ~965 1/cm, the band is ascribed to the W=O and W-O inside WO₃ [25, 26].

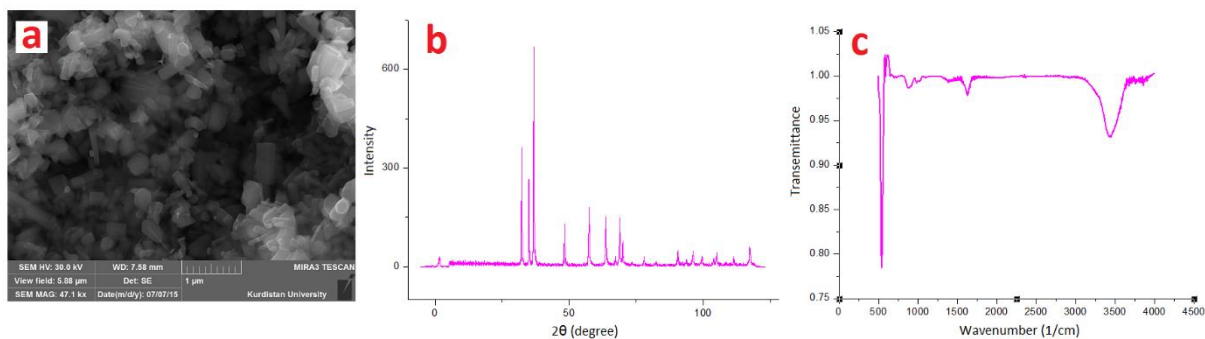

Fig. 1. SEM images (a), XRD pattern (b) and FTIR spectra (c) of the ZnO nanoparticle (1 % WO₃)

The observations of impact of the solution pH on removal efficiency of the process: the ZnO nanoparticles doped by 1% WO₃ have been given in Figure 2a. As can be seen, in relatively acidic pHs, the method had better performance than neutral and alkaline pHs; it may be because of the fact that pH value influenced the dominant electrical charge on the ZnO nanoparticles' surface. It is worth noting that the removal efficiency of diazinon is highly pH dependent because pH affects the ionization of pollutant,

as well as surface characteristics of the nanoparticles [27]. How different concentrations of the ZnO doped by 1% WO_3 affected the process performance has been indicated in Figure 2b. Apparently, with raising photocatalyst dosage (2-10 mg/cm^2), of the efficiency went up from 63 to 78%. The data of the effect of testing several initial diazinon contents on the performance of the ZnO nanoparticles doped by 12% WO_3 have been depicted in Figure 2c. Apparently, with increasing initial diazinon content declined removal efficiency.

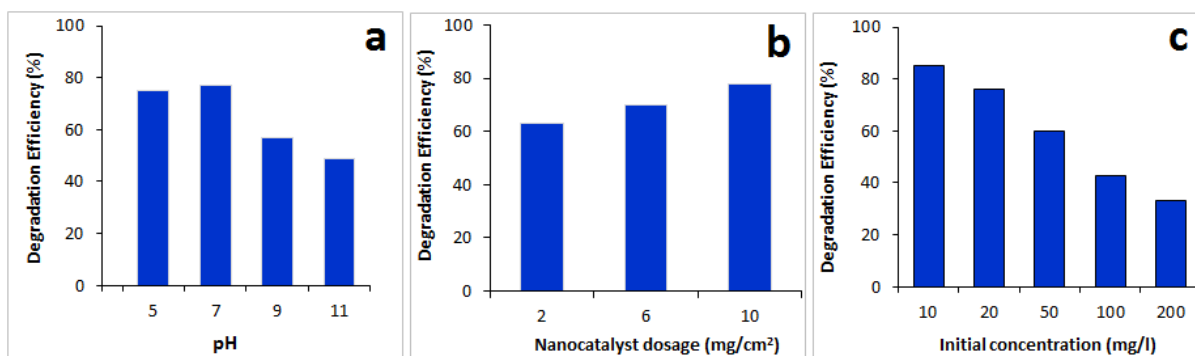

Fig. 2. Effect of 1% WO_3 doped ZnO dosage on photocatalytic removal of diazinon (a pH, b nanocatalyst dose and c initial diazinon content)

CONCLUSION

It was found that the ZnO nanoparticles doped using WO_3 declined the network constant and enhanced its density; this caused the photocatalytic performance to improve. Additionally, an increase in nanoparticle dose and reaction time increased the removal efficiency of diazinon. To sum up, the application of the ZnO nanoparticles doped by means of WO_3 can beneficially degrade pesticides from aqueous environments. Moreover, the consumption of the nanoparticles declined when they were immobilized. As a result, the amount of the contaminant released to the environment declines.

ACKNOWLEDGEMENT

Research reported in this publication was supported by Elite Researcher Grant Committee under award number [963307] from the National Institutes for Medical Research Development (NIMAD), Tehran, Iran. The main results of the study are published in the Journal of Molecular Liquids 297,111918. This paper is part of the results of that study, which has not been published in any journal. It is actually related to the results of experiments on 1% WO_3 doped ZnO nanoparticles.

REFERENCES

- [1] Daneshvar, N., Aber, S., Dorraji, M. S., Khataee, A., and Rasoulifard, M. Photocatalytic degradation of the insecticide diazinon in the presence of prepared nanocrystalline ZnO powders under irradiation of UV-C light, *Separation and purification Technology*, vol. 58, no. 1, pp. 91-98, 2007.
- [2] Azizi, A., Dargahi, A., and Almasi, A. Biological removal of diazinon in a moving bed biofilm reactor—process optimization with central composite design, *Toxin Reviews*, pp. 1-11, 2019.
- [3] Li, P., Swanson, E., and Gobas, F. Diazinon and its degradation products in agricultural water courses in British Columbia, Canada, *Bulletin of environmental contamination and toxicology*, vol. 69, no. 1, pp. 59-65, 2002.

-
- [4] Giddings, J. M., Hall Jr, L. W., and Solomon, K. R. Ecological risks of diazinon from agricultural use in the Sacramento–San Joaquin River Basins, California, *Risk Analysis*, vol. 20, no. 5, pp. 545-572, 2000.
- [5] Tabasideh, S., Maleki, A., Shahmoradi, B., Ghahremani, E., and McKay, G. Sonophotocatalytic degradation of diazinon in aqueous solution using iron-doped TiO₂ nanoparticles, *Separation and purification technology*, vol. 189, pp. 186-192, 2017.
- [6] Ebrahimzadeh, G., Alimohammadi, M., Rezaei Kahkha, M. R., and Mahvi, A. H. Contamination level and human non-carcinogenic risk assessment of diazinon pesticide residue in drinking water resources—a case study, IRAN, *International Journal of Environmental Analytical Chemistry*, pp. 1-12, 2020.
- [7] Avigliano, E., and Schenone, N. F. Human health risk assessment and environmental distribution of trace elements, glyphosate, fecal coliform and total coliform in Atlantic Rainforest mountain rivers (South America), *Microchemical Journal*, vol. 122, pp. 149-158, 2015.
- [8] Kumar, S. G., and Rao, K. K. Comparison of modification strategies towards enhanced charge carrier separation and photocatalytic degradation activity of metal oxide semiconductors (TiO₂, WO₃ and ZnO), *Applied Surface Science*, vol. 391, pp. 124-148, 2017.
- [9] Chan, S. H. S., Yeong Wu, T., Juan, J. C., and Teh, C. Y. Recent developments of metal oxide semiconductors as photocatalysts in advanced oxidation processes (AOPs) for treatment of dye waste-water, *Journal of Chemical Technology & Biotechnology*, vol. 86, no. 9, pp. 1130-1158, 2011.
- [10] Gusain, R., Gupta, K., Joshi, P., and Khatri, O. P. Adsorptive removal and photocatalytic degradation of organic pollutants using metal oxides and their composites: A comprehensive review, *Advances in colloid and interface science*, vol. 272, p. 102009, 2019.
- [11] Maleki, A., Moradi, F., Shahmoradi, B., Rezaee, R., and Lee, S.-M. The photocatalytic removal of diazinon from aqueous solutions using tungsten oxide doped zinc oxide nanoparticles immobilized on glass substrate, *Journal of Molecular Liquids*, vol. 297, p. 111918, 2020.
- [12] Shahmoradi, B., Maleki, A., and Byrappa, K. Removal of Disperse Orange 25 using in situ surface-modified iron-doped TiO₂ nanoparticles, *Desalination and Water Treatment*, vol. 53, no. 13, pp. 3615-3622, 2015.
- [13] Naik, M. M., Naik, H. B., Nagaraju, G., Vinuth, M., Vinu, K., and Rashmi, S. Effect of aluminium doping on structural, optical, photocatalytic and antibacterial activity on nickel ferrite nanoparticles by sol–gel auto-combustion method, *Journal of Materials Science: Materials in Electronics*, vol. 29, no. 23, pp. 20395-20414, 2018.
- [14] Elias, M., Amin, M. K., Firoz, S. H., Hossain, M. A., Akter, S., Hossain, M. A., Uddin, M. N., and Siddiquey, I. A. Microwave-assisted synthesis of Ce-doped ZnO/CNT composite with enhanced photo-catalytic activity, *Ceramics International*, vol. 43, no. 1, pp. 84-91, 2017.
- [15] Cañón, A. M. R. Nanostructured ZnO films for water treatment by photocatalysis, University of Bath, 2014.
- [16] Kar, J., Das, S., Choi, J., Lee, Y., Lee, T., and Myoung, J. M. Fabrication of UV detectors based on ZnO nanowires using silicon microchannel, *Journal of Crystal Growth*, vol. 311, no. 12, pp. 3305-3309, 2009.
- [17] Shahmoradi, B., Namratha, K., Byrappa, K., Soga, K., Ananda, S., and Somashekar, R. Enhancement of the photocatalytic activity of modified ZnO nanoparticles with manganese additive, *Research on Chemical Intermediates*, vol. 37, no. 2-5, pp. 329-340, 2011.
- [18] Zheng, J., Song, J., Zhao, Z., Jiang, Q., and Lian, J. Optical and magnetic properties of Nd-doped ZnO nanoparticles, *Crystal Research and Technology*, vol. 47, no. 7, pp. 713-718, 2012.
- [19] Sajjad, A. K. L., Shamaila, S., Tian, B., Chen, F., and Zhang, J. Comparative studies of operational parameters of degradation of azo dyes in visible light by highly efficient WO_x/TiO₂ photocatalyst, *Journal of Hazardous Materials*, vol. 177, no. 1-3, pp. 781-791, 2010.

- [20] Leghari, S. A. K., Sajjad, S., Chen, F., and Zhang, J. WO₃/TiO₂ composite with morphology change via hydrothermal template-free route as an efficient visible light photocatalyst, *Chemical Engineering Journal*, vol. 166, no. 3, pp. 906-915, 2011.
- [21] Bamwenda, G. R., Uesigi, T., Abe, Y., Sayama, K., and Arakawa, H. The photocatalytic oxidation of water to O₂ over pure CeO₂, WO₃, and TiO₂ using Fe³⁺ and Ce⁴⁺ as electron acceptors, *Applied Catalysis A: General*, vol. 205, no. 1-2, pp. 117-128, 2001.
- [22] Behnajady, M., Modirshahla, N., Daneshvar, N., and Rabbani, M. Photocatalytic degradation of an azo dye in a tubular continuous-flow photoreactor with immobilized TiO₂ on glass plates, *Chemical Engineering Journal*, vol. 127, no. 1, pp. 167-176, 2007.
- [23] Behnajady, M. A., Modirshahla, N., Mirzamohammady, M., Vahid, B., and Behnajady, B. Increasing photoactivity of titanium dioxide immobilized on glass plate with optimization of heat attachment method parameters, *Journal of hazardous materials*, vol. 160, no. 2, pp. 508-513, 2008.
- [24] Kwon, Y. J., Kim, K. H., Lim, C. S., and Shim, K. B. Characterization of ZnO nanopowders by the polymerized complex method via an organochemical route, *Journal of ceramic processing research*, vol. 3, no. 3/2, pp. 146-149, 2002.
- [25] Kumar, V. B., and Mohanta, D. Formation of nanoscale tungsten oxide structures and colouration characteristics, *Bulletin of Materials Science*, vol. 34, no. 3, pp. 435-442, 2011.
- [26] Díaz-Reyes, J., Dorantes-García, V., Pérez-Benítez, A., and Balderas-López, J. Obtaining of films of tungsten trioxide (WO₃) by resistive heating of a tungsten filament, *Superficies y vacío*, vol. 21, no. 2, pp. 12-17, 2008.
- [27] Hadi, M., McKay, G., Samarghandi, M. R., Maleki, A., and Solaimany Aminabad, M. Prediction of optimum adsorption isotherm: comparison of chi-square and Log-likelihood statistics, *Desalination and Water Treatment*, vol. 49, no. 1-3, pp. 81-94, 2012.

INFLUENCE OF MIXING INTENSITY ON ADSORPTION BEHAVIOUR OF ORGANIC POLLUTANTS ON MICROPLASTICS IN WATER

Maja Lončarski¹, Aleksandra Tubić^{1*}, Sanja Vasiljević¹, Jasmina Agbaba¹

¹University of Novi Sad, Faculty of Sciences, Department of Chemistry, Biochemistry and Environmental Protection, 21000 Novi Sad, Republic of Serbia

e-mail address: aleksandra.tubic@dh.uns.ac.rs

Abstract: In the present study, the influence of stirring rate on the adsorption behavior of organic pollutants (chlorinated phenols, benzene derivatives and polycyclic aromatic hydrocarbons) on microplastic was determined. Based on the obtained results, the lowest adsorption affinity of selected organic compounds was determined at a stirring speed of 50 rpm, with the gradual increase at higher mixing rates (100-200 rpm). The highest adsorption rate of chlorinated phenols, benzene derivatives and polycyclic aromatic hydrocarbons on the selected types of microplastics was determined at 150 rpm and did not change with further increase of speed (up to 200 rpm). Based on the obtained results of optimization of conditions for future adsorption studies of organic pollutants on microplastics 150 rpm agitation speed is selected as the optimal.

Key words: microplastic, organic pollutants, mixing speed, adsorption

INTRODUCTION

Recently, the presence and distribution of microplastics in the global aquatic environment have attracted increasing attention. Microplastics have been detected all over the world, including in freshwater, soil, coastal ecosystems, open seas, surface water and sediments [1,2]. Microplastics can adsorb organic pollutants and metals, such as polychlorinated biphenyls, polycyclic aromatic hydrocarbons (PAHs), and heavy metals, due to its physico-chemical properties [3–6]. It is also apparent that microplastics have become a subject of great concern, representing possible threats to the biota in the environment, due to its individual toxicity.

Real water environments are complex, and the comparisons between adsorption behavior of organic pollutants on microplastics in freshwater and synthetic waters matrix are limited. Adsorption of organic molecules on microplastics depends on various factors like temperature, pH of the solution, structure and concentration of the adsorbing molecule, ionic strength of the suspension, structure of the adsorbent and mixing speed. Mixing speed is an important parameter in adsorption phenomena, influencing the distribution of the compound in the water matrix resulting in different adsorption behavior [7]. Therefore, in this study, the influence of mixing speed on adsorption behavior of three different groups of organic pollutants (chlorinated phenols, benzene derivatives and PAHs) in presence of microplastics in water was studied.

MATERIAL AND METHODS

In this study, three groups of organic compounds were investigated: chlorinated phenols (4-chlorophenol, 4-CP; 2,4-dichlorophenol, 2,4-DCP; 2,4,6-trichlorophenol, 2,4,6-TCP and pentachlorophenol, PCP), benzene derivatives (1,2,3-trichlorobenzene, 1,2,3-TeCB; 1,2,4-trichlorobenzene, 1,2,4-TeCB; 1,3,5-trichlorobenzene, 1,3,5-TeCB; pentachlorobenzene, PeCB; hexachlorobenzene, HeCB and trifluralin, TFL) and polycyclic aromatic hydrocarbons (naphthalene, fluorene, fluoranthene and pyrene). Physico-chemical characteristics of the selected organic pollutants are shown in Table 1. Based on the literature review, the behavior of organic pollutants in the presence of microplastics in water significantly depends on their physico-chemical properties. Due to that, in this study, all selected organic pollutants were chosen by its relevance to the environment and the differences in their physico-chemical properties.

Table 1. Physico-chemical properties of selected organic pollutants

Compound	Molecular weight	$\log K_{ow}$	Water solubility (mg/l)	pK_a	Reference
4-CP	128	2,40	27100	9,41	[8]
2,4-DCP	163	3,06	4500	7,90	
2,4,6-TCP	197	3,69	800	6,40	
PCP	266	5,12	14	4,80	
1,2,3-TeCB	181	4,05	12,2	-	
1,2,4-TeCB	181	4,02	49	-	
1,3,5-TeCB	181	4,19	3,99	-	
PeCB	250	5,18	0,81	-	[9]
HeCB	406	5,73	< 1	-	[10]
TFL	335	5,34	< 0,1	-	[10]
Naftalen	128	3,30	31	-	[8]
Fluoren	166	4,18	1,69	-	
Fluorenten	202	5,16	< 1	-	
Piren	202	4,88	0,135	-	

logK_{ow} - octanol-water partition coefficient; *pK_a* – dissociation Constant

Four types of commercially available microplastics were used (powdered polyethylene (PEp, Thermo Fisher Scientific), granular polyethylene (PEg), polyethylene terephthalate (PET) and polypropylene (PP) manufactured by Sigma Aldrich), as well as one bioplastic polylactic acid (PLA, Sigma Aldrich). In addition to selected commercially available types of microplastics, powdered polyethylene isolated from two different personal care products (PE_PCPs_1 and PE_PCPs_2) was also used in this study. The size of the selected microplastic particles ranged from 0.63 μm to 3 mm depending on the type of microplastic.

Hexane and methanol were purchased from J.T.Baker (for organic residue analysis grade), acetic anhydride and hydrogen peroxide from Sigma-Aldrich. Analytical grade reagents, anhydrous calcium chloride (CaCl_2), sodium hydrogen carbonate (NaHCO_3), and magnesium sulphate heptahydrate ($\text{MgSO}_4 \cdot 7\text{H}_2\text{O}$), purchased from Sigma-Aldrich.

The study was performed by using a digital shaker (IKA® Orbital shaker KS 501 Digital). During the experiments four different speeds were used, 50, 100, 150, and 200 rpm. The initial concentration of the selected organic pollutants (chlorinated phenols, benzene derivatives and PAHs) was 100 $\mu\text{g/l}$, while the mass of the microplastics was 10 mg and 20 mg for powder and granular types of microplastics, respectively. The experiments were performed in duplicate and the pH value of the synthetic aqueous matrix was 7.23 ± 0.06 . The effect of the mixing rate on the adsorption behavior of selected organic compounds on microplastics was investigated after 48 h. The difference in the adsorption behavior of selected organic pollutants on microplastics was estimated by measuring the residual concentration of organic compounds in water.

RESULTS AND DISCUSSION

Optimum mixing speed is essentially important in terms of maximizing the interactions between selected organic pollutants and microplastic in water [7,11]. The obtained results of the effect of different mixing speed on the adsorption behavior of chlorinated phenols on microplastics are shown in Figure 1. The lowest adsorption rate of chlorinated phenols for selected types of microplastics was determined at a stirring speed of 50 rpm, with the 10-40% adsorbed concentration, relative to initial concentration. With the increase of the mixing speed up to 150 rpm, the adsorption rate increases. The highest adsorbed amount of chlorinated phenols (29-79.1 $\mu\text{g/l}$) on the selected types of microplastics was determined at 150 rpm and did not change with further increase of mixing speed up to 200 rpm. It can further be noted, from the results presented on Figure 1, that there are variations in affinity of different chlorinated phenols towards investigated types of microplastics. Thus, 4-CP shows highest affinity towards PET, while more hydrophilic 2,4,6-TCP and PCP best adsorbed on PE originated from personal care product (PE_PCPs_1), with 60% of compound adsorbed at 150 rpm. On the

contrary, 4-CP shows lowest affinity towards PE_PCPs_1, while 2,4,6-TCP and PCP on PET. 2,4-DCP shows similar affinity towards both PET and PE_PCPs_1, with maximum adsorption rate of about 70%.

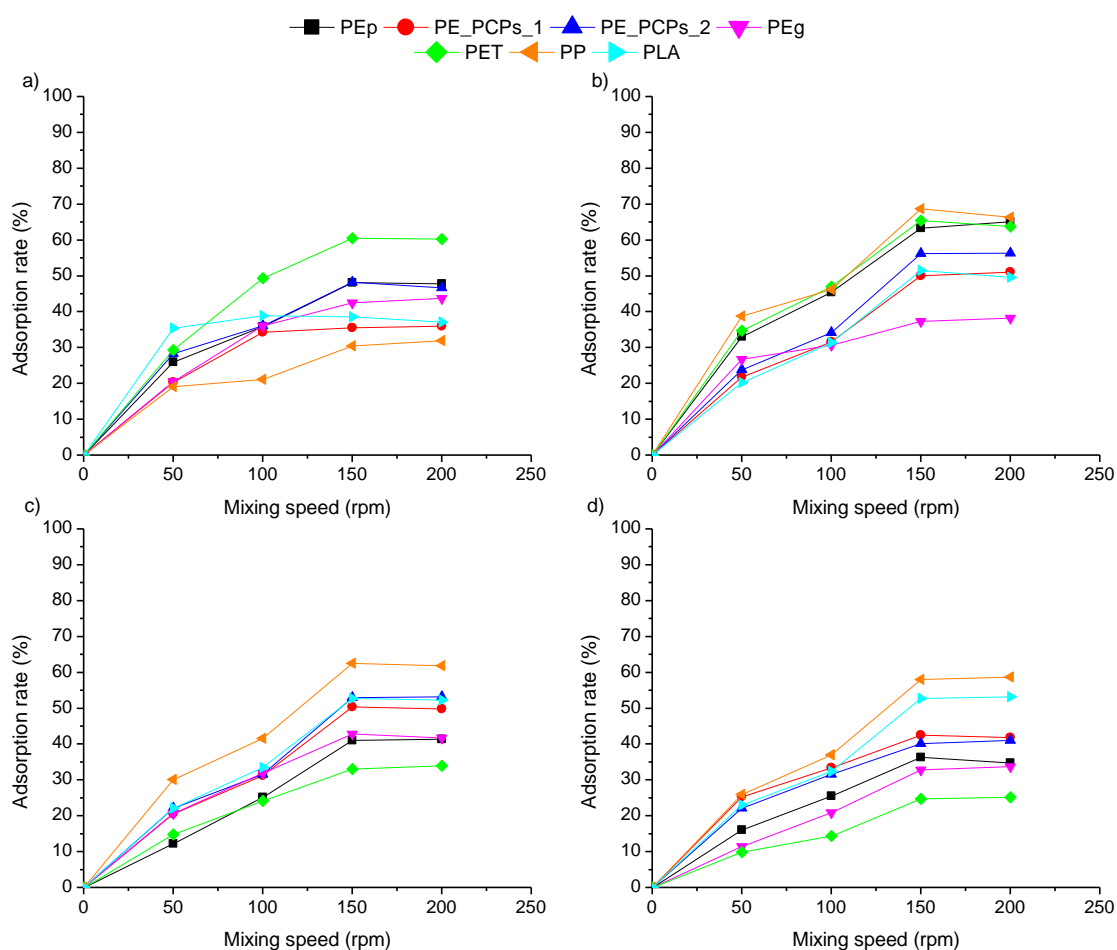

Fig. 1. Influence of mixing speed on the adsorption behavior of a (a) 4-CP, (b) 2,4-DCP, (c) 2,4,6-TCP and (d) PCP on microplastics in water

The influence of mixing speed was also conducted for selected benzene derivatives and polycyclic aromatic hydrocarbons adsorption on seven types of microplastic and the results are shown in the Figures 2 and 3.

The obtained results indicate the same trend of increasing the adsorption affinity of benzene derivatives and PAHs on microplastics with an increase in the stirring speed from 50 up to 150 rpm. At the speed of 50 rpm the lowest affinity of the benzene derivatives and PAHs was determined towards microplastics, with 10-45% and 10-60% of the compounds is adsorbed, respectively. With an increase in the mixing speed up to 100 rpm, an increase in the adsorption percentage was determined for benzene derivatives and PAHs on PEp, PE_PCPs_1, PE_PCPs_2, PEg, PET and PP, ranging from 25-80% and 45-80%, as well as 25-70% and 20-55% for PLA, respectively. With the increase of mixing speed up to 200 rpm, approximately the same adsorption percentage was determined for selected compounds in comparison to the results obtained at 150 rpm. At these stirring speeds, 150-200 rpm, the adsorption rate of benzene derivatives and PAHs on selected types of microplastics ranged from 45-95%, and 55-98%, respectively. The obtained results in this study are in line with the results of other authors who applied mixing speed of 150 rpm in the investigation of the adsorption of different groups of organic pollutants on microplastics in water [12–16].

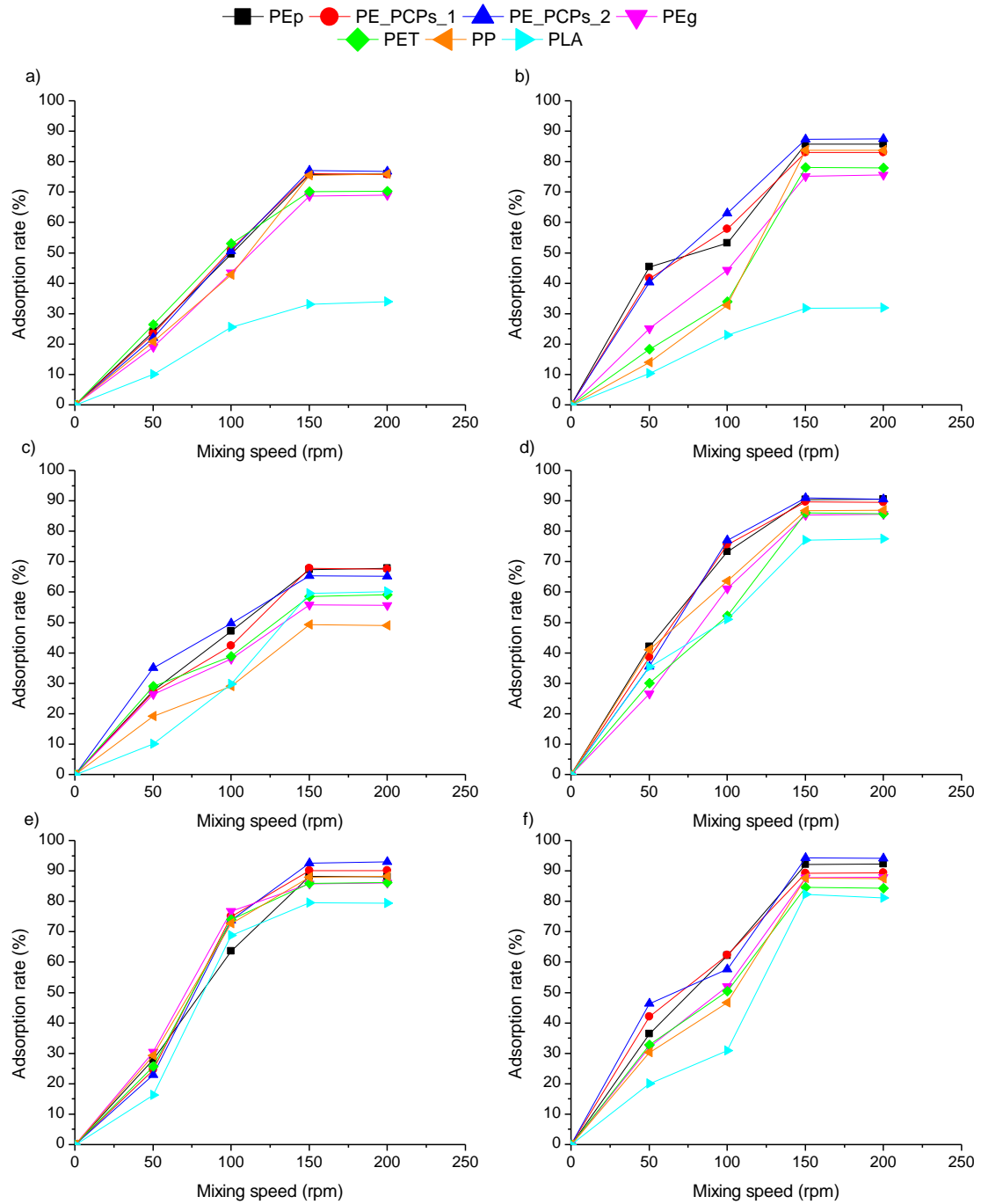

Fig. 2. Influence of mixing speed on the adsorption behavior of (a) 1,2,3-TeCB, (b) 1,3,5-TeCB, (c) 1,2,4-TeCB, (d) PeCB, (e) HeCB and (f) TFL on microplastics in water

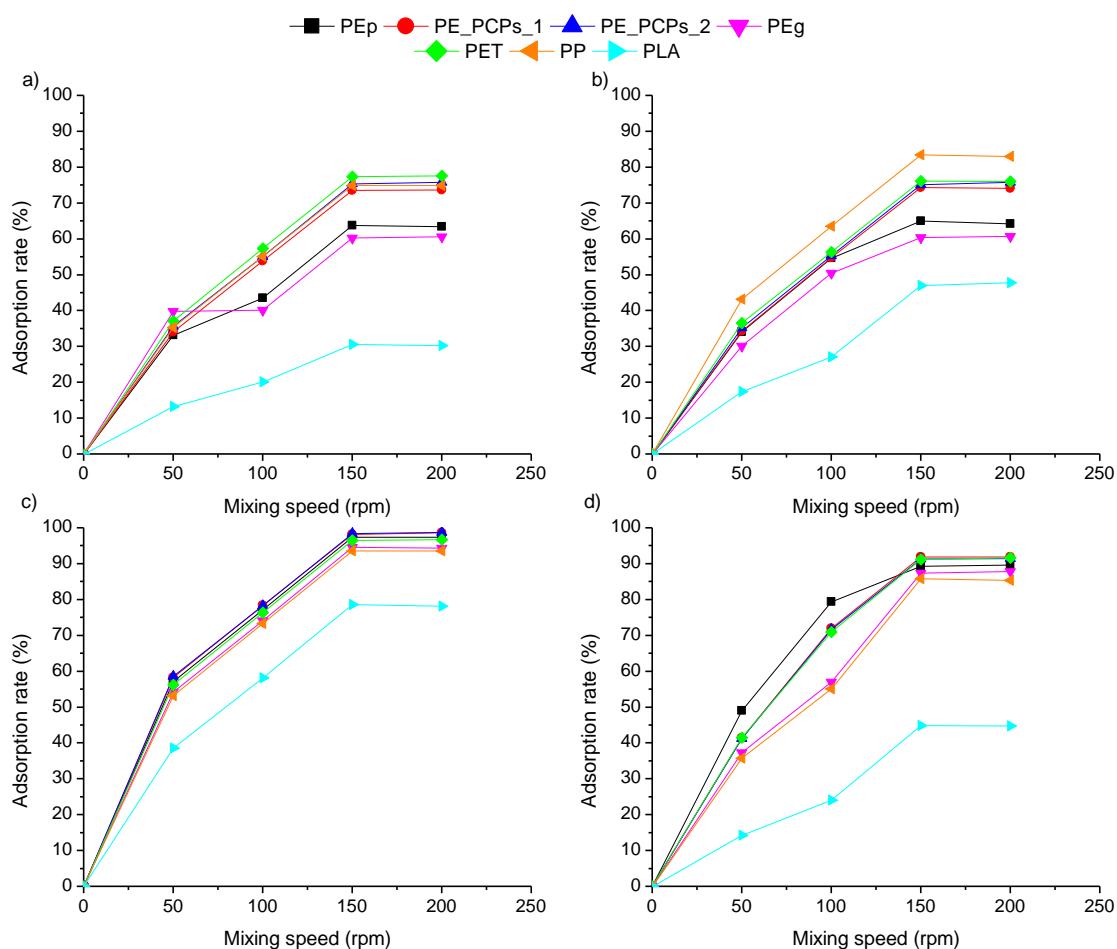

Fig. 3. Influence of mixing speed on the adsorption behavior of (a) naphthalene, (b) fluorene, (c) fluoranthene and (d) pyrene on microplastics in water

The obtained results indicate that the increase of the mixing speed improves the diffusion of selected organic pollutants towards the surface of the microplastics in water. The increase of mixing speed reduces the boundary layer resistance and increases the mobility of the system. With the increase of mixing speed, the external mass transfer coefficient increases resulting in quicker adsorption of the selected pollutants [7]. Based on the obtained results, the optimal mixing speed for maximum adsorption of chlorinated phenols, benzene derivatives and PAH is 150 rpm, which is in accordance with the conditions which have been applied in other studies [14–17].

CONCLUSION

In this study, the influence of mixing speed on adsorption behavior of chlorinated phenols, benzene derivatives and PAHs in presence of seven types of microplastics in water was studied. Changing the mixing rate has a significant effect on changing the degree of adsorption of chlorinated phenols, benzene derivatives and PAH. The effect is reflected in the increase of the degree of adsorption with the increase of the mixing speed. The maximum percentage of adsorption was achieved at a mixing speed of 150 rpm, and with a further increase in the mixing speed there was no change in the adsorbed amount of tested organic pollutants on the polyethylene, polyethylene terephthalate, polypropylene and polylactic acid type microplastics.

ACKNOWLEDGEMENTS:

The authors acknowledge financial support of the Ministry of Education, Science and Technological Development of the Republic of Serbia (Grant No. 451-03-68/2020-14/ 200125)

REFERENCES

- [1] Eerkes-Medrano, D., Thompson, R.C., Aldridge, D.C., Microplastics in freshwater systems: A review of the emerging threats, identification of knowledge gaps and prioritisation of research needs, *Water Res.* 75, 63–82, 2015.
- [2] Li, J., Liu, H., Paul Chen, J., Microplastics in freshwater systems: A review on occurrence, environmental effects, and methods for microplastics detection, *Water Res.* 137, 362–374, 2018.
- [3] Fries, E., Zarfl, C., Sorption of polycyclic aromatic hydrocarbons (PAHs) to low and high density polyethylene (PE), *Env. Sci Pollut Res.* 19, 1296–1304, 2012.
- [4] Holmes, L.A., Thompson, R.C., Interactions between trace metals and plastic production pellets under estuarine conditions, *Mar. Chem.* 167, 25–32, 2014.
- [5] Besseling, E., Wegner, A., Foekema, E.M., Van Den Heuvel-Greve, M.J., Koelmans, A.A., Effects of microplastic on fitness and PCB bioaccumulation by the lugworm *Arenicola marina* (L.), *Environ. Sci. Technol.* 47, 593–600, 2013.
- [6] Velzeboer, I., Kwadijk, C.J.A.F., Koelmans, A.A., Strong Sorption of PCBs to Nanoplastics, Microplastics, Carbon Nanotubes, and Fullerenes, 2014.
- [7] Nandi, B.K., Goswami, A., Purkait, M.K., Adsorption characteristics of brilliant green dye on kaolin, *J. Hazard. Mater.* 161, 387–395, 2009.
- [8] Niederer, C., Schwarzenbach, R.P., Goss, K.U., Elucidating differences in the sorption properties of 10 humic and fulvic acids for polar and nonpolar organic chemicals, *Environ. Sci. Technol.* 41, 6711–6717, 2007.
- [9] McCarty, L., Lupp, M., Shea, M. Chlorinated benzenes in the aquatic environment, 1984.
- [10] Li, H., Sheng, G., Sheng, W., Xu, O., Uptake of trifluralin and lindane from water by ryegrass, *Chemosphere.* 48, 335–341, 2002.
- [11] C. Goedecke, C., Stollin, U.M., Hering, S., Richter, J., Piechotta, C., Paul, A., Braun, U., A First Pilot Study on the Sorption of Environmental Pollutants on Various Microplastic Materials, *J. Environ. Anal. Chem.* 04, 1–8, 2017.
- [12] Lee, H., Shim, W.J., Kwon, J-H.H., Sorption capacity of plastic debris for hydrophobic organic chemicals, *Sci. Total Environ.* 470–471, 1545–1552, 2014.
- [13] Balati, A., Shahbazi, A., Amini, M.M., Hashemi, S.H., Adsorption of polycyclic aromatic hydrocarbons from wastewater by using silica-based organic–inorganic nanohybrid material, *J. Water Reuse Desalin.* 5, 50–63, 2015.
- [14] Wang, F., Shih, K.M., Li, X.Y., The partition behavior of perfluorooctanesulfonate (PFOS) and perfluorooctanesulfonamide (FOSA) on microplastics, *Chemosphere.* 119, 841–847, 2015.
- [15] Guo, W., Wang, S., Wang, Y., Lu, S., Gao, Y., Sorptive removal of phenanthrene from aqueous solutions using magnetic and non-magnetic rice husk-derived biochars, *R. Soc. Open Sci.* 5, 2018.
- [16] Liu, G., Zhu, Z., Yang, Y., Sun, Y., Yu, F., Ma, J., Sorption behavior and mechanism of hydrophilic organic chemicals to virgin and aged microplastics in freshwater and seawater, *Environ. Pollut.* 246, 26–33, 2019.
- [17] Wu, C., Zhang, K., Huang, X., Liu, J., Sorption of pharmaceuticals and personal care products to polyethylene debris, *Environ. Sci. Pollut. Res.* 23, 8819–8826, 2016.

ARE WE AWARE OF MICROPLASTIC CONTENTS IN TOOTHPASTES?

Anja Bubik¹

¹Environmental Protection College, Velenje, Slovenia

e-mail: anja.bubik@vsvo.si

Abstract: Personal care and cosmetic products (PCCPs) are worldwide used products among all population. Variety of studies have already emphasized the environmental and human health concern about the use of microplastics in PCCPs and since 2019, European Union aims to restrict the intentional use of microplastics in those products. This work represents a brief review of microplastics in PCCPs with the focus on microplastic components, called microbeads, in toothpastes. Main goals of our research were first, to examine the availability and accessibility of toothpastes with microplastic content in Slovenia and second, to analyze public awareness on this issue.

Key words: microplastics, microbeads, personal care and cosmetic products, toothpastes, public awareness

INTRODUCTION

Plastics are a crucial part of 21st century life and can be found almost everywhere around us. As a result of all its versatile and attractive properties, plastics are being used in the wide range of consumer and industrial applications. We use plastic products to make our lives cleaner, safer, easier, and more comfortable. However, this valuable commodity has been the subject of the increasing environmental concern. Due to the mass production, plastic and microplastic contamination of the environment is a growing problem. While some plastic waste is recycled, the majority ends up in landfill. Of particular concern are plastics that, through indiscriminate disposal, are entering the marine environment and due to its high resistance to degradation creates and disposes a plastic waste. It is estimated that up to 10% of plastics produced end up in the oceans, where they may persist and accumulate [2, 3, 4].

In recent years, microplastics has been reported in diverse aquatic ecosystems, therefore increasing environmental concern about it was established worldwide. Microplastics are characterized as synthetic or semi-synthetic, water insoluble and nondegradable solid particles with high polymer content and with a size range below 5 mm [5]. They can be found as raw materials in several products (primary production) or can be produced by the breakdown of (macro)plastic products (secondary production). It is established, that an average consumer discards 2.4 g of microplastics daily [5]. Microplastics have a potential to cause harm to biota. Due to the small size they are considered bioavailable to organisms throughout the food-web. Additionally, their composition and relatively large surface area make them prone to adhering aquatic pollutants. As a result, ingestion of microplastics may cause the toxin exposure and bioaccumulation trough the food chain [3, 4, 5].

In personal care and cosmetic products (PCCPs) microplastic components are intentionally added with the aim to improve their characteristics. They are best known and used as abrasives, which intended to remove dead skin and cleanse the skin [6]. They are also added as exfoliating, binding, suspending (emulsifier), film forming, thickening, aesthetic, opacifying or anti-static agents [5]. When used in PCCPs, microplastics are often termed microbeads: those are tiny particles generally smaller than 1 mm in size. Microplastics in leave-on products, like lotions, make-up, deodorants, sunscreens, are even smaller, around micrometer to nanometer range [5, 7]. Toothpastes are known to contain abrasives for cleaning tooth surfaces, and in certain toothpastes, abrasives represent microbeads. They are also added to toothpastes for decorative purposes. However, dentists had observed microbeads trapped in the gums of patients, which can pose a serious problem as the area between the teeth and gums is extremely sensitive [8]. Despite the microbeads from cosmetic products do not contribute with high percentages to the microplastic pollution, they can pose a threat to the environment [9, 10]. Therefore, we must be aware of microplastics issue and prevent its global accumulation with all potentially hazard consequences, the most easily by avoiding the use of such products.

There is no legislation in the European Union (EU) completely banning the use of microplastics in PCCPs. However, as part of the EU Plastics Strategy, the European Commission has initiated the restriction process regarding intentionally added microplastics under REACH, chemical regulations of

the EU. In January 2019, the European Chemical Agency (ECHA) proposed a wide-ranging restriction on intentional uses of microplastics in products placed on the EU/EEA market to avoid or reduce their release to the environment. The proposal is estimated to reduce emissions by at least 70% and prevent the release of 500.000 tons of microplastics over the 20-year period following its introduction [11, 12].

MATERIAL AND METHODS

Our research was based on two types of methods. First, we randomly examined toothpastes from variety of Slovenian cosmetics or grocery shops and drugstores (N=200). We checked the microplastics content based on their declarations and compare our results with the public available database of the Plastic Soup Foundation initiative “*Beat the Microbead*” [13, 14].

With the restriction proposal by the ECHA and the reports by UNEP and TAUW, Plastic Soup Foundation provides a list of more than 500 microplastic ingredients, widely used in PCCPs [6, 15, 16]. They created four product categories: Red, Orange, Green, & Zero. Products on the Red list have been found to contain ingredients which are commonly considered to be microplastic ingredients (e.g. *Polyethylene (PE)*, *Polypropylene (PP)*, *Polymethyl methacrylate (PMMA)*, *Nylon (PA)*, *Polyurethane*, and *Acrylates Copolymer*). Products on the Orange list contain “sceptical microplastic” ingredients (e.g. *Polyquaternium*, *Poloxamer*, *PEGs*, and *PPGs*). Those are synthetic polymers for which there is not sufficient information available about their impact on human and environmental health. Products on the Green list do not contain any microplastic or “sceptical microplastic” ingredients. However, brands on this list might not have their entire range of products free of all possible microplastic ingredients. Brands on the Zero list have their entire range of products free of all known microplastic ingredients, carrying the “*Zero Plastic Inside*” certification logo [13, 14].

Second, we performed the online survey (N=117) to gain the public knowledge on microplastics in general and microbeads in toothpastes specifically. We were focus on people's awareness of microplastics in PCCPs and their consumer experiences.

RESULTS AND DISCUSSION

Microplastics in toothpaste

Among 200 toothpastes, 162 adult (81%) and 38 (19%) children's toothpastes were examined. Based on the reviewed declarations, 52% (104) of toothpastes contained microplastics, 17.3% of them were for children (Figure 1; left column). Thirty different toothpaste brands were included in our research; in 13 brands microplastics were not recognized. However, among other 17 brands, 10 (33.3%) were described as “critical” on our opinion since no product was without microplastics.

We found polyethylene glycols (PEGs) as the most common plastic component in toothpastes and were present in 66.4% of all examined toothpastes with microplastic content (Table 1). Polyethylene glycols comprise a class of polymers varying in molecular weights between 200 and over 10.000 and are usually followed by a number, which represents the approximate molecular weight of the compound (e.g. PEG-6, PEG-32). These compounds and their derivatives (e.g. PEG fatty acid esters, ethers) are used in a vast variety of cosmetic applications because of their solubility and viscosity properties, and because of their low toxicity. They produce little or no ocular or dermal irritation and have extremely low acute and chronic toxicities [17]. Typically, cosmetics use PEGs with smaller molecular weights due to their higher ability to penetrate the skin (Table 1).

Table 1. PEGs types and ratios among examined toothpastes

Plastic component	Type of polymer	N°	%
PEG - 6	PEG	36	28,8
PEG – 32	PEG	23	18,4
PEG - 12	PEG	14	11,2
PEG – 8	PEG	5	4,0
PEG – 30 Glyceryl Stearate	PEG derivate*	3	2,4
PEG – 40 Stearate	PEG derivate*	1	0,80
PEG – 30 Glyceryl Stearate	PEG derivate*	1	0,80
		83	66,4%

*PEG fatty acid ester

After the comparison of our results to the “Beat the Microbead” database, we categorized our toothpastes into 3 groups: Red, Orange, and Green. Among 104 toothpastes, which contain microplastics based on their declaration, 100 can be directly compared with the database. The comparison revealed that only 11% of them (equal to approx. 6% of all examined toothpastes) can be classified into the Red group (Figure 1, middle column). The result was expected due to the high proportion of PEGs into the toothpastes. Within our Red group, only two toothpastes are for kids (18,2%), and 9 are for adults (81,8%) (Figure 1, right column). Due to the abundance of products within the Orange list it is worth to briefly discuss about the relevance of this data. Since the harmful effect of microplastics from the Orange list on human and environmental health has not been completely described yet, we suggest some causation in use of such PCCPs.

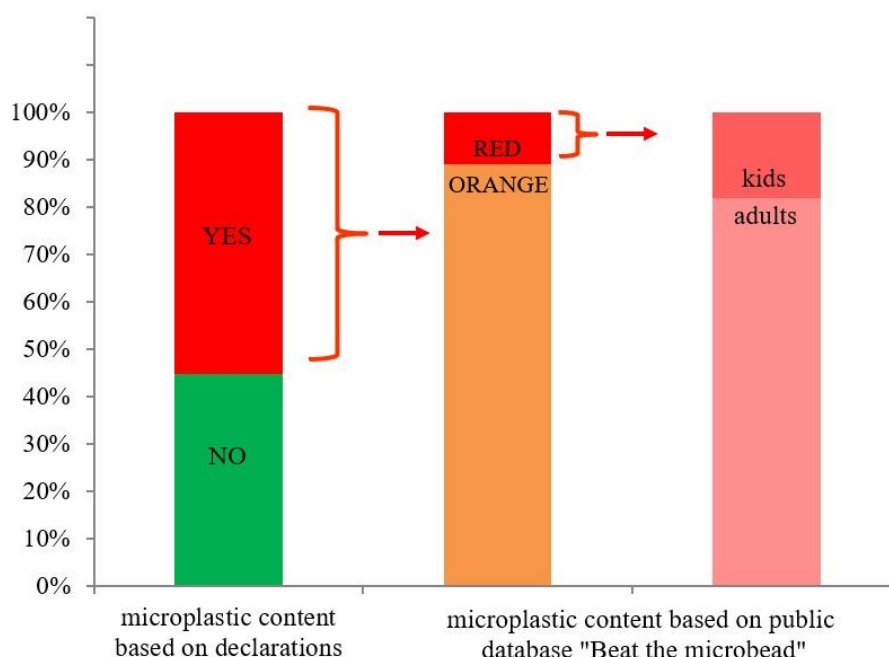

Fig. 1. Toothpastes with and without microplastic ingredients

Microplastics awareness

Respondents to the online survey are familiar with the term of “microplastics” (78,6%) (Figure 2, left column) and more than a half of them (62,4%) think, that microplastics is parts of their daily life [18]. However, they recognized this issue associated with various processes or activities (Table 2). Only 36,8% was aware of microplastics in PCCPs. The term was mostly connected to ocean accumulation and therefore the threat to marine organisms (Table 2).

Table 2. How the respondents know the term “microplastics”?

I know microplastics because they are...	%
dangerous.	58,1
often present around us.	56,4
found in daily used PCCPs.	36,8
found in the food.	32,5
accumulated in the oceans and threaten marine organisms.	67,5
present in food chain.	41,0
harmful for human health.	57,3
present in clothes.	35,0

Regarding toothpastes specifically, approximately a half of respondents do not know (55,6%), that microplastics are present in toothpastes (Figure 2, right column) and they do also not pay attention on microplastic ingredients (91,5%) while shopping for them. The survey unequivocally shows that microplastics issue should be more exclusively and often presented to people. Especially to children and youth, which are the most acceptable and future-influential population.

If we compare the general knowledge on microplastics to the knowledge of the microplastics only in toothpastes, results clearly show the lack of knowledge regarding microplastics (microbeads) in toothpastes. Our survey shows the decrease in knowledge for 34,2% (Figure 2). On our opinion, this result is especially important, since toothpastes are one of the rare PCCPs, which is used in all population: from children to elderly, in men and woman. Additionally, toothpaste is the product, which is used even up to few times daily and is applied orally. Some amount can be swallowed and metabolized, and the rest of it is flushed through the sewage system. It is already well known that microbeads from PCCPs enter the environment through the wastewater treatment plant effluents [9, 19, 20]. Even though wastewater treatment plants are capable of partial eliminating of microplastics, these systems are still the important source of microplastics introduction in the environment due to the high volumes of effluents generated and returned to the environment [10]. Consequently, microplastics are transferred to various water ecosystems, where they cannot be degraded and are thus accumulated. For example, the research in Slovenia (Ljubljana as a case study) showed that high amounts of polyethylene microbeads are used in cosmetics and that treated wastewater can contain substantial amounts of microbeads [19].

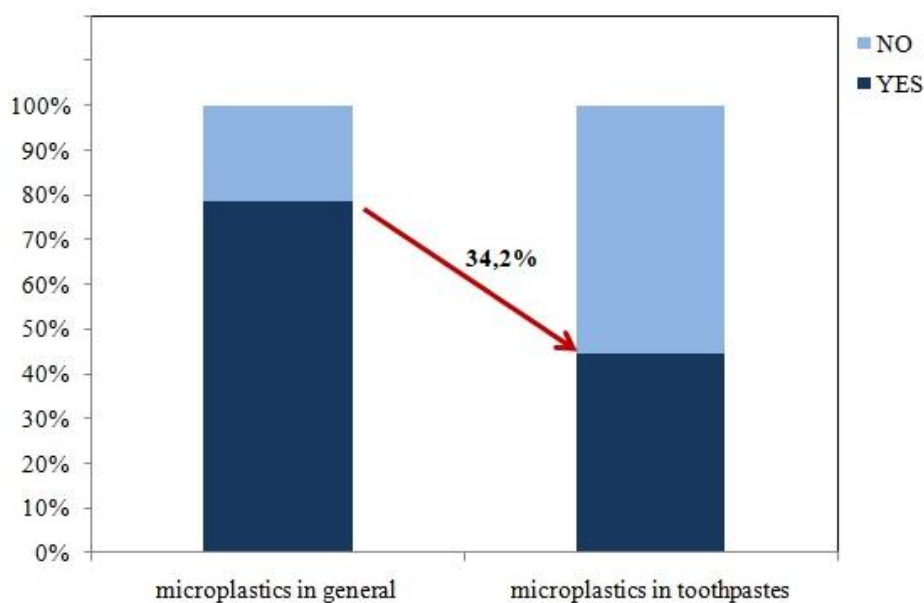

Fig. 3. Knowledge on microplastics in general (left) and in toothpastes (right)

The aim of our survey was also to introduce different types of microplastics in toothpastes. As we expected, 76,9% did not know any of their exact names, however, PEGs were mostly recognized by 17,9% of respondents, probably due to widely use of PEGs in different plastic materials in a huge and

growing range of applications. Strong indicator of the small awareness was also the result, that 47,7 % of respondents usually buy the toothpaste brand, which (based on our first part of research) contain the most products with microplastic ingredients. If we cluster these results by the brands, the results revealed that 75,3% of respondents buy toothpastes with microplastic ingredients in average.

At the end, responded concluded, that the most important reason, why microplastics should be restricted in PCCPs, is the fact, that they have a serious impact on human health (68,4%) (Table 3) [18].

Table 3. Why should be microplastics restricted in PCCPs?

Because of the...	%
pharmaceutical interests	-
possible increase in PCCPs marketing	1,7
aim to increase the use of natural products	6,0
negative impact of microplastics on water organism	11,1
accumulation of microplastics in the environment	12,8
serious impact of microplastics on human health	68,4

CONCLUSION

Based on the fact, that microbeads are continuously released into freshwaters as a result of massive and diverse use of PCCPs, we should not underestimate the importance of microplastics issue. Our research suggests that microbeads are included in our daily habits and we are not sufficiently aware of this phenomenon. The ability of their bioaccumulation in the environment must convince us to reduce the use of such products on personal and social levels. Therefore, it is important to intensively raise public awareness about microplastics in PCCPs and to offer environmentally friendly solutions and alternatives, which in many cases already exist. On the other hand, this area needs to be regulated unanimously at European Union level.

Acknowledgement

I would like to thank my undergraduate student Katrin Školnik Škrabe from Environmental Protection College for her excellent work on gaining practical data on microplastics contents in toothpastes.

REFERENCES

- [1] Internet source: PlasticEurope website: <https://www.plasticseurope.org/en>.
- [2] Thompson, R.C., Swan, S.H., Moore, C.J., vom Saal, F.S., Our plastic age, *Philosophical Transactions of the Royal Society B: Biological Sciences*, Vol. 364, pp. 1973-1976, 2009.
- [3] Cole M., Lindeque P., Halsband C., S. Galloway T., Microplastics as contaminants in the marine environment: A review, *Marine Pollution Bulletin*, Vol. 62, pp. 2588-2589, 2011.
- [4] Revel, M., Chatel, A., Mouneyrac, C., Micro(nano)plastics: A threat to human health?, *Environmental Science and Health*, Vol.1, pp. 17-18, 2018.
- [5] Mahesh, B.P., Mukherjee, M., Yadav, K., Padhi, L., Personal (eco) care product: Microplastics in cosmetics. *Toxics link for a toxics-free world*, Vol.17, pp. 1-29, 2018.
- [6] European Chemicals Agency (ECHA), Annex to the Annex xv restriction report, Proposal for a restriction. Helsinki, Finland, pp.148-149, 2019.
- [7] Hirst, D., Bennett, O., Microbeads and microplastics in cosmetic and personal care products, Briefing paper. House of commons library, Vol. 7510, pp. 3-4, 2017.
- [8] Internet source: Microbeads in Toothpaste, Cambridge Polymer Group website: <http://www.campoly.com/>.
- [9] Guerrantia, C., Martellini, T., Perrac, G., Scopetanib, C., Cincinelliab, A., Microplastics in cosmetics: Environmental issues and needs for global bans, *Environmental Toxicology and Pharmacology*, Vol. 68, pp. 75-79, 2019.
- [10] Bretas Alvim, C., Mendoza-Roca, J.A., Bes-Piá, A., Wastewater treatment plant as microplastics release source – Quantification and identification techniques, *Journal of Environmental Management*, Vol. 255, 109739, 2020.

- [11] Internet source: European Chemicals Agency (ECHA) website: <https://echa.europa.eu/home>.
- [12] Kentin, E., Restricting microplastics in the European Union: Process and criteria under REACH, *The European Physical Journal Plus*, Eur. Phys. J. Plus Vol.133, pp. 1-12, 2018.
- [13] Internet source: Plastic Soup Foundation website: <https://www.plasticsoupfoundation.org/en/>.
- [14] Internet source: Beat The Microbeads website: <https://www.beatthemicrobead.org/>.
- [15] UNEP, *Plastic in Cosmetics*, pp. 1-38, 2015.
- [16] TAUW, *Test to assess and prevent the emission of primary synthetic microparticles (primary microplastics)*, pp. 1-75, 2015.
- [17] Fruijtier-Pölloth, C., *Safety assessment on polyethylene glycols (PEGs) and their derivatives as used in cosmetic products*, *Toxicology*, Vol. 214, pp. 1-33, 2005.
- [18] Školnik Škrabe, K., *Prisotnost mikroplastike v zobnih pastah v Sloveniji (The presence of microplastics in toothpastes in Slovenia)*, *Diplomsko delo (Diploma thesis)*, Environmental Protection College, Velenje, pp. 1-51, 2020.
- [19] Kalčíková, G., Alič, B., Skalar T., Bundschuh, M., Žgajnar Gotvajn, A., *Wastewater treatment plant effluents as source of cosmetic polyethylene microbeads to freshwater*, *Chemosphere*, Vol.188, pp. 25-31, 2017.
- [20] Hu, L., Gong, M., Wang, J. & Bassi, A., *Current research trends on microplastic pollution from wastewater systems: a critical review*, *Reviews in Environmental Science and Bio/Technology*, Vol.18, pp. 207-230, 2019.

WASTE LUBRICATING OILS, ENVIRONMENTAL IMPACT, RECYCLING AND STATE IN THE REPUBLIC OF SERBIA

Snežana Filip¹, Snežana Komatina¹

¹University of Novi Sad, Technical Faculty "Mihajlo Pupin", Zrenjanin, Serbia

e-mail: zana@tfzr.uns.ac.rs, komsne@yahoo.com

Abstract: At the end of life cycle lubricating oils become toxic/hazardous waste, and a serious soil, water and air contaminants. Waste motor oil is many times more dangerous than other waste, because the composition and content of toxic substances cannot be predicted in advance, so it becomes a significant environmental problem. In this review, the impact of waste oil on the environment, possibility and technologies for the recycling of waste lubricating oil, as well as the state in the Republic of Serbia were discussed.

Key words: waste motor oils, recycling, environmental protection, Serbia.

INTRODUCTION

According to the By-law of the conditions, manner and procedure of waste oils management (Official Gazette of Republic of Serbia, No. 71/2010) *waste oils* are all mineral or synthetic oils or lubricants, which are unusable for the purpose for which they were originally intended, such as hydraulic oils, motor, turbine oils or other lubricants, marine oils, oils or fluids for insulation or heat transfer, other mineral or synthetic oils, as well as oil residues from tanks, oil-water mixtures and emulsions, in accordance with the law governing waste management [1,2].

Waste oils are generated in many areas, but the most important are [3]:

- automotive industry (maintenance of propulsion engines, fluids used in transmission mechanisms, fluids used in braking mechanisms),
- production activity - ferrous and nonferrous metallurgy, rolling mills, metal processing (heating and cooling media), process and chemical industry,
- other activities – in energetic (transformer oils), agriculture, forestry and mining.

Waste lubricants are classified as harmful, toxic and carcinogenic waste materials, and of course, soil, water and air contaminants. Carriers of toxicity and carcinogenicity are the products of oxidation and thermal decomposition of lubricants. The oxidation processes of lubricants take place constantly, not only during exploitation, but also during storage, where acidic products, resins and asphaltene are formed. The degree of toxicity and carcinogenic potential depend on the concentration and character of the pollutants. Concentrations of pollutants and degradation products depend on the length of oil use, operating conditions and engine characteristics. Of the external contaminants present in the oil, the following have been identified:

- lead compounds and other fuel combustion products, polycyclic aromatics originating from fuels (present in motor oils),
- polychlorinated biphenyls (PCB) and polychlorinated terphenyls (PCT),
- various solvents, chlorinated hydrocarbons,
- oxides of nitrogen and sulfur,
- metal shavings in cutting oil,
- microorganisms in waste emulsions.

During one oil change interval in diesel motor oil, the concentration of polycyclic aromatics increases tenfold, and in gasoline motor oil a hundredfold. This means that waste oils from gasoline engines are a bigger environmental problem than oils from diesel engines. However, in diesel engines, solid particles in the exhaust gases are also an environmental problem. Hydrocarbons of unburned fuel and unburned oil are adsorbed on them [3].

Such a wide use of oils and lubricants means, at the same time, a large dispersion of waste oils and at the same time a potentially large polluter of the environment. Waste oils thus represent a problem for the environment, although, they can be a very useful secondary raw material, which is especially important for oil-importing countries.

The impact of motor oil on the working and living environment

All previous research has shown that all types of lubricants, produced, used or waste, are polluting the environment. Waste lubricating oils, regardless of the quality of base oils and additives, show a certain toxicity and carcinogenicity. Carriers of such properties are various pollutants and degradation products of oils that occur during their use. As we said before, the most environmentally dangerous are motor waste oils especially from gasoline engines.

Contamination of the working and living environment with lubricating oils occurs, usually, due to oil leakage, the appearance of oil mist and intentional or unintentional spillage of oil due to improper storage and handling. Analyzing the situation in our country, it can be concluded that oil pollution of the working environment is a relatively common phenomenon caused by improper handling of oils and inadequate maintenance of machines and equipment that use lubricants [4].

All lubricants, especially waste, destroy the soil microflora and make it infertile for a long time, because they are biologically difficult and slow decompose (Table 1).

Table 1. Biodegradability of lubricating oils [4]

Type of base oil	Biodegradability (%)	
	EPA method*	CEC method**
Mineral oils	42 – 48	20 – 40
Vegetable oils	72 – 80	90 – 98
Polyglycols	6 – 38	-
Synthetic esters	55 – 84	90 – 100

* EPA - Environmental Protection Agency, USA; **CEC - Coordinating European Council

The presence of waste lubricating oils in rivers, lakes and streams endangers the living world in those areas. In very small concentrations, the water is unusable for drinking. The literature states: that 1 liter of oil is enough to pollute one million liters of water potentially usable for drinking; and that the amount of oil, from 50 to 100 ppm in a liter of water, is sufficient to endanger the processes of water treatment [4]. Oil stains on the surface of the water, disturb the exchange of oxygen (aeration), influence the reducing of light and thereby interfere with the process of photosynthesis. Oil and emulsions in water can practically destroy the production of algae and plankton, which directly reduces the amount of fish food. Therefore, a negative impact of waste lubricating oils is present on the complete flora and fauna.

DISCUSSION

Possible solutions for environmental protection

EU Directive 2008/98 / EC [5] on waste oils define the collection, recovery and disposal of waste oils, with the aim of protecting the environment from the harmful effects of illegal disposal and treatment. Due to the great environmental problems created by waste motor oils, the EU countries have approached the solution of this problem in two ways. One is the use of rapidly biodegradable lubricants in sensitive ecosystems, and the other is related to the collection and recycling of used oils. The reduction of waste oil through the use of rapidly biodegradable lubricating oils (e.g. lubricants based on vegetable oils) is increasing, as a result of the implementation of environmental protection policy and the adoption of appropriate legislation.

Reducing the amount of waste oil can be achieved by [4]:

- Prolonging the lubricating oils life, which can be achieved by using high quality oils, adequate handling and storage, as well as purification during use;
- Using rapidly biodegradable oils to lubricate machinery and equipment used in sensitive environments such as agriculture, forestry and water management;
- Organized collection of waste oil and
- Recycling of waste oil.

In this case, organized collection of waste oils is the basis for further waste management procedures. Very widespread use of oil in different areas provides a wide dispersion of waste oil on a large space, making it difficult for the collection, storage and processing, as well as in technical and in financial sense. Also, the amount of waste oil is related to the consumption of lubricants. Experiences of some countries show that up to 40% of lubricating oil is lost during use by combustion, evaporation, transport and lag in tanks, containers and packaging. This means that it is realistically possible to collect 60% to 70% of the lubricant consumption. The current state of the waste oil management system in the EU countries is given in Fig. 1. From 56% of generated used oil, 75% is collected.

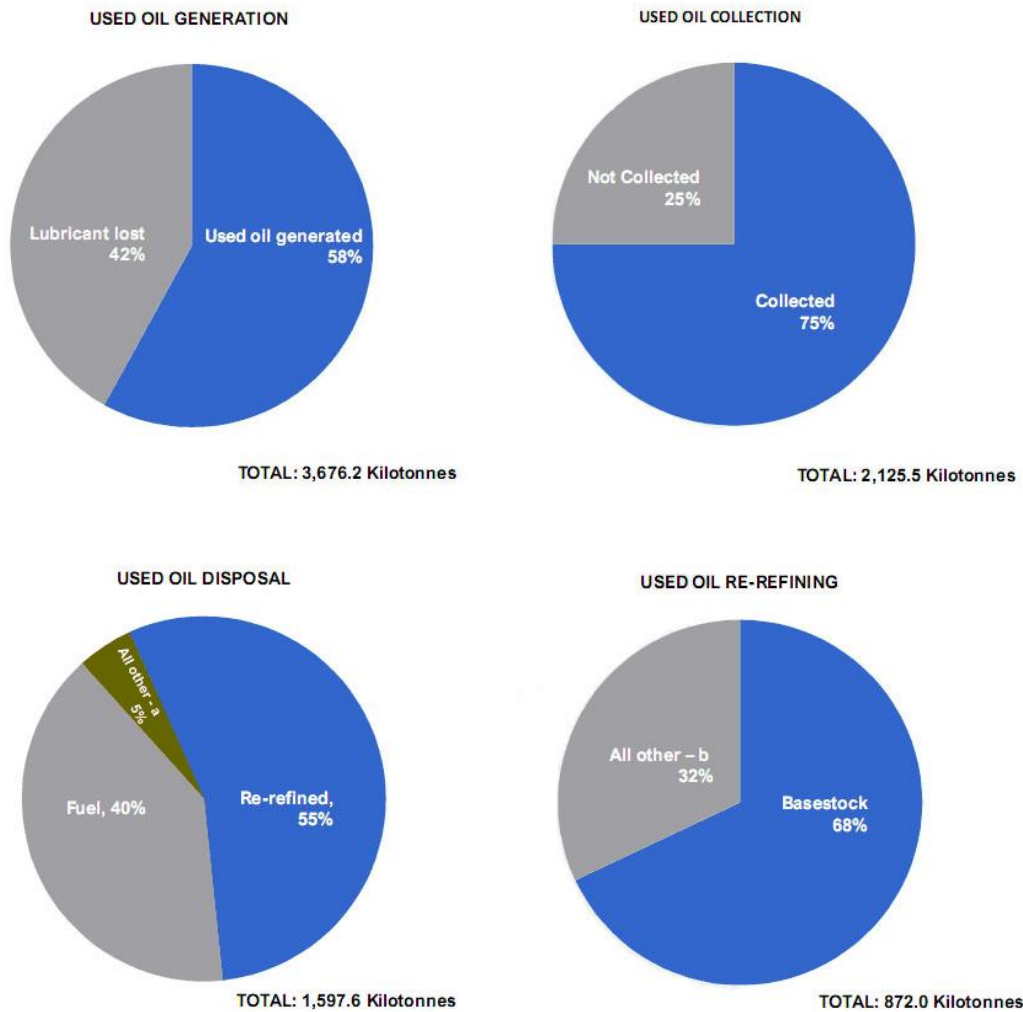

Fig. 1. Lubricant and used oil material balance in the EU for 2019 (a. Direct incineration and neutralization, b, Gasoil and bitumen) [6]

When collecting waste oil, the physico-chemical characteristics that the waste oil must satisfy are also prescribed (Table 2). In addition, waste oils must not contain: solvents, PCB/PCT, brake fluids, diesel/gasoline, antifreeze, fuel oil, liquids containing chlorine and other substances prescribed by waste oil collectors. Also, selective collection request non-mixing of oil from different sources, i.e. non-mixing of oil with other waste.

Table 2. Physico-chemical characteristics that the waste oil must satisfy for collection [6]

Parameter	Unit	Test method	Typical data
Color			Black
Density at 15°C	kg/m ³	EN ISO 3675	880 - 900
Flash point (open cup)	°C	EN ISO 2719	> 70
Viscosity at 40°C	mm ² /s	EN ISO 3104	50 - 70
Water content	% w/w	ISO 3733	≤ 5.0
Sulfur	% w/w	EN ISO 8754	≤ 0.6
Chlorine	% w/w	ISO 15597	< 0.1
PCB	mg/kg	EN 12766 – 1,2	< 5.0
Ash content	% w/w	EN ISO 6245	≤ 0.9
Sediments	% w/w	ISO 3734	≤ 1.0

The conversion of waste oils into commercially usable products is achieved today through numerous processes [7]:

- Incineration,
- Regeneration and
- Re-refining.

Today, a large part of the collected waste oils is burned in appropriate facilities, in order to obtain thermal energy. In this case, it is necessary to precisely and reliably control the emission of harmful substances that are created as combustion products, from heavy metals (Pb, Zn, Cu, Cd) to waste gases (NO_x, N₂O, SO₂, P₂O₅), and some halogen acids.

Regeneration is a relatively simple procedure. Gravitational deposition of water and other coarse pollutants, oil separation by decantation, filtration, and centrifugation are used. Therefore, used oils, which are not heavily contaminated and chemically degraded, can be recycled to reuse. Purification can be carried out by oil users themselves or the work is left to specialized companies. This procedure is recommended wherever there is a technical and economic justification.

Re-refinement produces re-refined base oils, which are used to produce new lubricants. After the separation of coarse mechanical impurities, processes such as atmospheric and vacuum distillation, solvent or hydrorefining and others technologies, are combined. In the world is an increasing number of companies who are engaged in re-refining, i.e. the production of refined base oils. For these purposes, various technologies have been patented and used.

Waste engine oil management in the Republic of Serbia

According to available data, about 55,000 tons of finished lubricants annually are placed on the market of Serbia. Given that between 50% and 60% of waste oils can be collected from the quantity placed on the market, it means that the amount of waste oil generated is between 26,000 and 33,000 tons per year [6]. According to the Serbian Environmental Protection Agency (SEPA), in the year 2015, a 3,042 tons of waste oil were treated in treatment facilities (combustion and preparation for combustion) and 245 tons were exported, while in the year 2016, a 4,343 tons were treated and 116 tons were exported, which in total represents about 7% of the total quantities placed on the market [8]. Otherwise, the data of the Agency are not complete and the Agency has distances itself from them in its reports. For example, the Agency's report states that in the year 2016, about 16,500 tons of oil were placed on the market, and the data of the Republic Bureau of Statistics show that the quantity is 3 to 4 times higher. According to the SEPA, in the year 2018, 5,042 tons of waste mineral and synthetic oils were treated in treatment facilities (combustion and preparation for combustion) and 186 tons were exported, which represents a total of about 9.5% of the total quantities placed on the market [6].

In any case, all this data is devastating, especially if we take into account that the facilities that treat waste oils for reuse have a very bad, outdated technology. According to the available information, the products obtained in this way end up on the illegal market as an addition to fuel oil and diesel.

When it comes to Serbia, this problem has not been solved in any way, i.e. there is no well-organized system of waste oil management. In order to establish an efficient waste oil management system, and

to respect the hierarchy of waste management it is necessary to amend By-law of the conditions, manner and procedure of waste oils management (Official Gazette of Republic of Serbia, No. 71/2010). The current By-law is outdated, vague and technical and regulatory incomplete. It is also necessary, first, to separate waste motor oils from waste edible oils. Furthermore, it is necessary to clearly define what and how we can work with waste oils, what conditions are necessary for a permit for the management of this type of waste, especially for storage [9], but also the treatment of waste oils as well as the quality of the product obtained by the treatment/re-refining process. In this way, it would be avoided that the “treatment” of waste oils is carried out in facilities that do not have the appropriate permits, and in which some types of fuels of undefined quality are produced, and are not controlled by anyone. Also, it is necessary to consolidate the entire legislation related to this matter. Strict application of the provisions by all who are involved in the chain of a waste oil management, as well as compliance with the statutory regulations would significantly increase the amount of waste oil collected, and reduced impact on the environment.

CONCLUSION

Used motor, industrial and other oils are hazardous for the environment, flammable, volatile and toxic, very often carcinogenic. The largest amount of waste oil from motor vehicles ends up in the landfill, or in the city sewage, or is thrown to the ground. Therefore, it is necessary to improve the situation regarding the disposal of used oil in the near future. The introduction of precisely defined legislative regulations in the field of waste lubricant management, its application, good establishment of the waste oil collection system is of paramount importance for the environment. The experience of European countries shows that by establishing a good system of collecting motor oils, up to 95% of waste oil can be collected, and about 60% of the collected waste oil can be re-refined. The importance of waste lubricants recycling is also in reducing the consumption of fossil fuels, achieving profits and getting new products (base oils for lubricants new production) as an important vision of circular economy.

REFERENCES

- [1] By-law of the conditions, manner and procedure of waste oils management (Official Gazette of Republic of Serbia, No. 71/2010).
- [2] Law on waste management (Official Gazette of Republic of Serbia, No.36/2009, 88/2010, and 14/2016).
- [3] Stojiljković, M., Pavlović, M., Impact of lubricants on the environment, *Goriva i maziva (GOMABN)*, 48, 1, pp. 75-81, 2009.
- [4] Rac, A., Ekološki i tehnički aspekti recikliranja otpadnih ulja za podmazivanje, *Tribologija u industriji*, 1-6, 2011.
- [5] The Waste Oil EU Directive 2008/98 / EC from 12 December 2010.
- [6] Avista oil d.o.o <https://www.avista-oil.rs/> presentation (15.09.2020)
- [7] Recycling Possibilities and Potential Uses of Used Oils, Regional Activity Centre for Cleaner Production (RAC/CP), 2000.
- [8] Serbian Environmental Protection Agency (<http://www.sepa.gov.rs/> 12.09.2020).
- [9] Mitrović, J., Urošević, D., Janković, V., Recovery of waste oil, *PTEP*, 12, pp. 245-248, 2008.

EXPERIMENTAL INVESTIGATION OF THE THERMAL DEGRADATION OF FOREST LITTER - PINE NEEDLES

Nikola Mišić¹, Milan Protić¹

¹University of Niš, Faculty of Occupational Safety, Serbia

e-mail: nikola.misic@znrfaq.ni.ac.rs, milan.protic@znrfaq.ni.ac.rs

Abstract: For prediction fire behavior in forests, it is necessary better understanding of burning dynamics. Experimental activities cover many subjects related to wildland fires including among others: fire behavior, fire impact, fuel characterization, fire emissions and fire detection. Pine forests present a relatively high flammability risk comprised in great part by pine needles. This work investigate flammability characteristics of pine needles, using bench-scale mass loss calorimeter. For consistency with real conditions, it was made custom porous circular sample holder. Tests were conducted on mass loss calorimeter for heat flux of 70 kW/m². Mass loss calorimeter provide data to evaluate and understand how different materials burn at a small scale.

Key words: pine needles, mass loss calorimeter, flammability, heat release rate, mass loss rate

INTRODUCTION

According to the damages and consequences wildfire cause, as well as the areas of forests that are destroyed every year, wildfires are a global problem and require the engagement of all institutions and subjects of society to prevent their occurrence and extinguishment.

Wildland fuels and fire behavior have been the focus of numerous studies and models which provide operational support to firefighters. In regard to wildfires, observing statistical data in the past, the impact of warmer and drier weather has a tendency to become stronger in the future [1]. Climate is recognized as the major cause of fire patterns on a global scale [2].

Flammability of vegetation fuels relates to inner characteristics of fuel and fuel type related to the four components (ignitability, combustibility, sustainability and consumability). Dibble et al. [3] mention that these components can be evaluated in a bench-scale calorimeter test. In addition to this, fire hazard includes fuel quantity, condition, arrangement and location. Combining those data with the meteorological, are very important to calculate fire hazard [4]. "Vegetation fuels" term include both live and dead vegetation parts, regardless of meteorological conditions and disintegration, that can be potentially be combusted [5].

Surface fuels is the most used to predict fire behavior, because most wildfires spread through surface fuels. For that reason it gets the most attention in fire management. Many ecosystems have the surface fuel types of litter, shrubs, and herbaceous fuels in different quantities above the ground surface. Forest litter consists a wide variety of fallen plant parts. The most common parts is plant foliage (needles and leaves) [6]. Pine needles are representative of the Mediterranean ecosystem, and they have always been described as flammable.

Experiments with small scale equipment provide necessary data for quantifying the importance of different parameters involved in a fire. Especially in term of wildfires, fuel species, moisture content, fuel load and flow velocities are parameters that have impact on ignition and intensity of these fires [7].

Jervis et al [8] reports laboratory results on the burning of live, aged and dead (fresh and dried) pine needles. The paper is directed towards determination to understand the flammability changes between live and dead fuels. Madrigal et al [9] study the flammability of live plant parts due to the variability in fuel moisture content.

For all mention articles, the same approach is observed in flammability research, such as the fuel sample, used heat flux (50 kW/m²) and same design of sample holder. McAllister et al [10] reports that though wildfires typically produce radiant heat fluxes in the range of 50–250 kW/m². In this regard, and based on literature review, this study deals with flammability investigation of pine needles, for heat flux of 70 kW/m².

MATERIAL AND METHODS

Description of the experimental device

Based on laboratory studies and measurements from fires in controlled conditions fire models can be developed, improved and validated. For flammability investigation of different materials, calorimetric devices was used such as cone calorimeter, fire propagation apparatus and mass loss calorimeter. From all devices two main data sets can be exported: heat release rate and mass loss rate. Mass loss calorimeter uses a calibrated thermopile positioned in the exhaust duct in order to calculate the heat release rate.

To investigate the thermal degradation of pine needles, experimental tests were conducted with the adapted bench-scale mass loss calorimeter device (Figure 1). Mass loss calorimeter (MLC) is made by Fire Testing Technology, United Kingdom. The MLC provides observing the sample reaction during thermal exposure to different heat fluxes. It has possibility of generating heat flux in the range of 10–100 kWm². Pilot ignites the flammable gas mixture released upon pyrolysis of the sample. The sample is positioned in a sample holder connected to a load cell.



Fig. 1. Bench-scale Mass Loss Calorimeter

During the analysis it is possible to obtain the following data: peak HRR (kW/m²); peak EHC (MJ/kg); peak MLR (g/s); time to peak HRR (s); time to peak EHC (s); time to peak MLR (s); mean HRR (kW/m²); mean EHC (MJ/kg); mean MLR (g/s); total heat release (MJ/m²); percentage mass lost (%). As Anderson [11] and Martin et al [12] mention, those are the most important characteristics in terms of flammability of wildfires.

Before tests, it is necessary to carried out calibration of MLC, which consists 3 steps. The heater is calibrated first. In this step it is important to make correlation between heater temperature and heat flux. The second calibration is related on thermocouples, for heat release of 0.5 kW, 0.75 kW, 1 kW, 2 kW, 3 kW, 4 kW and 5 kW (Figure 2). This calibration is performed with a methane burner, for each of these heat release, the methane flow is precisely defined. Important note, before every tests, it is crucial to perform daily check for heat release rate, only for 3 kW. Last stage is related to scale calibration, for the expected mass of the sample, in order to increase the accuracy of the measurement.

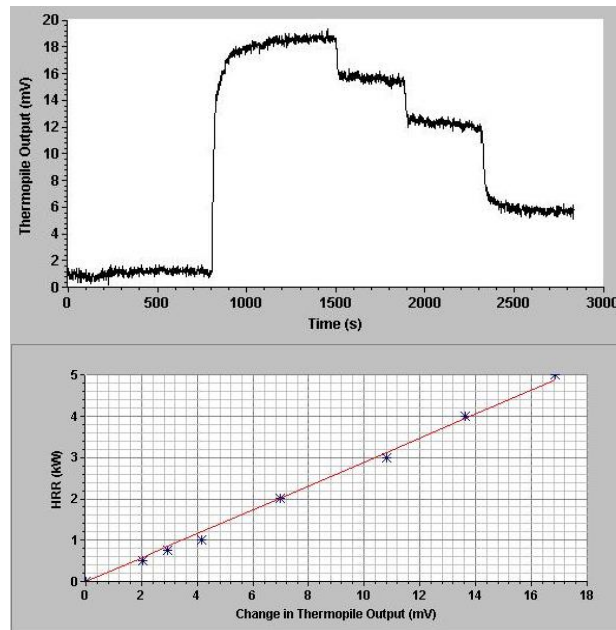

Fig. 2. Heat release rate calibration

Sample preparation

Pine needles were collected by hand from random location. For the experiment was made custom porous circular sample holder, with diameter of 13.5 cm and 3 cm in depth. Design of sample holder allows air to pass through the fuel sample, with the aim to simulate a forest litter. Prepared sample mass was 7.4 g (Figure 3). This mass correspond to a bulk density approximately to 20 kg/m^3 [8]. Note that samples of needles were conditioned in laboratory for three months before testing. These condition corresponds to aged needles.

The sample was exposed to a heat flux of 70 kW/m^2 , with piloted ignition. Distance between sample and heater was setup at 25 mm. Fan flow rate was taken to be 14 Hz, which is equal to flow rate of $0.024 \text{ m}^3/\text{s}$. Combustion tests were performed under the well-ventilated conditions.



Fig. 3. Collected and prepared pine needles for experiment

RESULTS AND DISCUSSION

Representative heat release rate and mass loss curves for a given experiment can be seen in the figures 4 and 5. For better visualization, MLR curve has been smoothed by moving average method (5 s period). Process of thermal degradation of pine needles can be separated in three phases:

- Pre ignition;
- Flaming combustion;
- Glowing combustion.

Obtained results from experiment were extracted and summarized in Table 1 to understand the combustion behavior.

Table 1. Summary of experimental results for pine needles for heat flux 70 kW/m²

Ignition time (s)	Flameout time (s)	Peak HRR (kW/m ²)	Peak EHC (MJ/kg)	Peak MLR (g/s)	Time to peak HRR (s)	Time to peak EHC (s)	Time to peak MLR (s)	Mean HRR (kW/m ²)	Mean EHC (MJ/kg)	Mean MLR (g/s)	Total heat release (MJ/m ²)	Percentage mass lost (%)
4	30	448.56	74.85	0.69	13	27	9	289.18	14.65	0.26	7.52	98.11

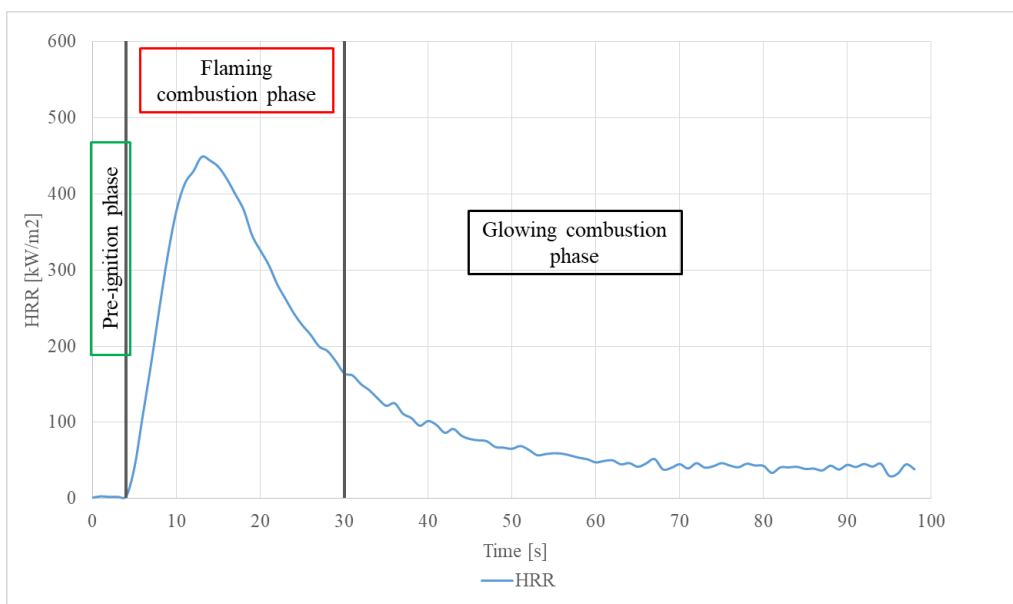

Fig. 4. HRR curve for pine needles

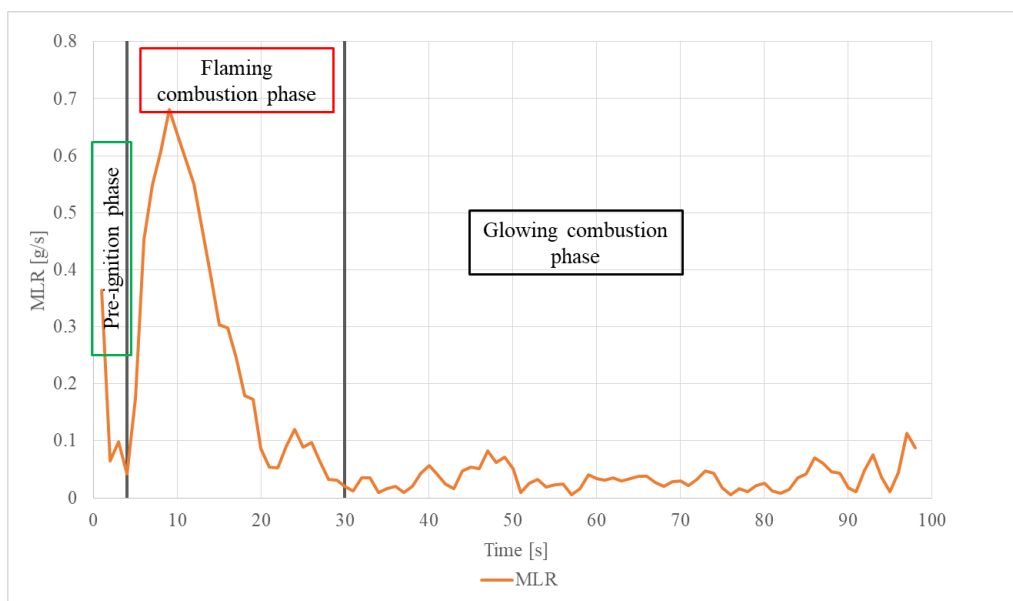

Fig. 5. MLR curve for pine needles

At moment where fuel sample was exposed to heat flux, sample starts to lose mass and producing volatile gases. Since piloted ignition was used, process of ignition starts. The fuel sample will rapidly release energy, until it reaches peak value (PHRR), in 13th second, which is 448.56 kW/m². Mass loss in moment before ignition starts is 10±1 %. Remaining water content of the fuel sample is lost during the pre-ignition phase, and this parameter has an impact on mass lost dynamics and to ignition time.

After reached PHRR, sample mass decrease, and there is no enough available for combustion, so the HRR starts a downward trend, because fuel sample is consumed rapidly in this regime. At the end of flaming combustion phase, 95±1 % of the sample mass has burned. Jervis et al [8] finds that in this phase of combustion, during exposure fuel sample at heat flux of 50 kW/m², mass loss is between 80 and 90 %.

From Figure 5 can be seen that flaming combustion phase is sustained until the moment where remaining sample mass mainly consists carbon and ash.

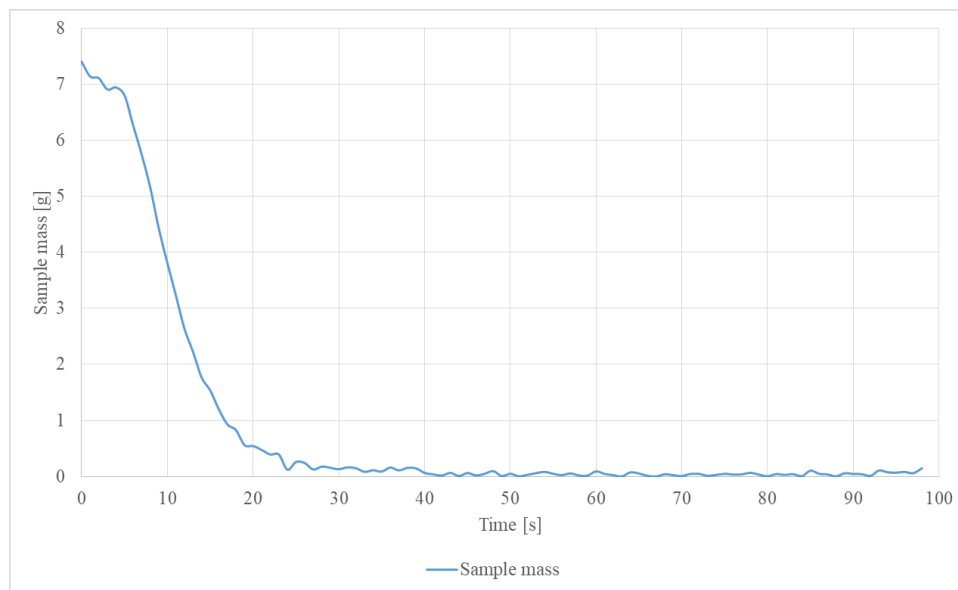

Fig. 6. Trend of sample mass loss per unit time

CONCLUSION

The present results demonstrate flammability characteristics of pine needles under heat flux of 70 kW/m². Ignition time starts at 4th second and flaming combustion phase lasts 26 s, while Jervis et al. [8], for aged needles, reports 13±1 and 32±2 seconds, respectively. Based on extracted data, PHRR is 448.56 kW/m², while Jervis finds that PHRR is 457±15 kW/m².

By comparing the results in this study with literature findings, following conclusion remarks can be written:

- There is similarities between PHRR values;
- Ignition and flaming time differs, 69±1% and 19±1%, respectively.

ACKNOWLEDGEMENTS

The authors would like to express gratitude to the Ministry of Education, Science and Technological Development of the Republic of Serbia for financing support to this researches.

REFERENCES

- [1] N. Khabarov et al., "Forest fires and adaptation options in Europe," *Reg. Environ. Chang.*, vol. 16, no. 1, pp. 21–30, 2016.
- [2] J. R. Marlon et al., "Climate and human influences on global biomass burning over the past two millennia," *Nat. Geosci.*, vol. 1, no. 10, pp. 697–702, Oct. 2008.
- [3] A. C. Dibble, R. H. White, and P. K. Lebow, "Combustion characteristics of north-eastern USA vegetation tested in the cone calorimeter: Invasive versus non-invasive plants," *Int. J. Wildl. Fire*, vol. 16, no. 4, pp. 426–443, 2007.
- [4] F. Moreira, M. Arianoutsou, P. Corona, and J. D. las Heras, *Post-Fire Management and Restoration of Southern European Forests*, vol. 24. Springer, 2012.
- [5] Z. Kauf, "Testing vegetation flammability: examining seasonal and local differences in six mediterranean tree species," 2016.
- [6] Robert E. Keane, *Wildland Fuel Fundamentals and Applications*. Springer, 2015.
- [7] F. X. J. Calle, "Application of fire calorimetry to understand factors affecting flammability of cellulosic material: Pine needles, tree leaves and chipboard," The University of Edinburgh, 2012.
- [8] F. X. Jervis and G. Rein, "Experimental study on the burning behaviour of *Pinus halepensis* needles using small-scale fire calorimetry of live, aged and dead samples," *Fire and Materials*, vol. 40, no. 3, pp. 385–395, 2016.
- [9] J. Madrigal, C. Hernando, and M. Guijarro, "A new bench-scale methodology for evaluating the flammability of live forest fuels," *J. Fire Sci.*, vol. 31, no. 2, pp. 131–142, 2013.
- [10] S. McAllister, I. Grenfell, A. Hadlow, W. M. Jolly, M. Finney, and J. Cohen, "Piloted ignition of live forest fuels," *Fire Saf. J.*, vol. 51, pp. 133–142, 2012.
- [11] H. E. Anderson, "Forest fuel ignitibility," *Fire Technol.*, vol. 6, no. 4, pp. 312–319, Nov. 1970.
- [12] M. RE et al., "Assessing the flammability of domestic and wildland vegetation," in *12th Conference on Fire and Forest Meteorology*, At Jekyll Island, GA, USA, Volume: pages 26-28, 1994, no. November, pp. 26–28., 1994.

ANALYSIS OF SOUND LEVELS OF FOOD COURTS AND COFFEE HOUSES AT UNIVERSITY CAMPUS IN NOVI SAD

Selena Samardžić¹, Robert Lakatoš¹, Aleksandra Mihailović^{1*}, Anja Ranković¹,
Slavko Rakić¹, Savka Adamović¹, Dragan Adamović¹

¹University of Novi Sad, Faculty of Technical Sciences, Novi Sad, Serbia

e-mail: zandra@uns.ac.rs

Abstract: The detrimental effects of a high level of noise on human health have been known for a long period. Noise disturbs work, rest, sleep, communication, and produce speech interference. Non-auditory effects of noise may include lack of concentration, irritation, fatigue, headache, tinnitus, cardiovascular problems, etc. The objective of this paper was to determine the noise level in four food courts and coffee houses at the University campus in Novi Sad and to find possible psychophysical effects of noise on customers. The noise measurements in all four facilities showed that the values exceeded the values given by the noise regulation in the Republic of Serbia. The results of the surveys show that noise causes more psychophysical effects in male than in female respondents and that greatest negative impact of noise was on the age groups between 30 and 35 and over 40 years of age.

Keywords: noise level, hospitality facilities, effects of noise, questionnaire

INTRODUCTION

It is a common opinion that noise is only a problem in industries which use the machines and equipment that produce high-intensity noise or, in the case of the living environment, in busy city roads. However, today the problem of noise is present in places where it is least expected, such as banks, IT companies and other organizations which require quiet and calm surroundings in order to operate successfully. In addition, significant noise levels are also generated in public places such as restaurants and coffee houses, which defy the original purpose of these objects, i.e. rest, relaxation and relaxed conversation. Noise levels in restaurants are a growing concern for customers, employees, and restaurant owners alike. In fact, there is a tendency to start including the loudness of restaurants as factors in their ratings. A recent survey found that noise in restaurants was ranked as customers' top complaint. All the sounds of conversations and kitchen noises are reflected by the surfaces in the restaurant or coffee houses. And as the coffee houses become busy there are more conversations and more noise to reflect and bounce around the space. Intelligibility of speech becomes a problem, particularly if people are also surrounded by other sources of sound like noise from air conditioners. According to [1] the ideal sound level for normal conversation is between 55 dB and 65 dB. In most restaurants and coffee houses noise levels are about 70 dB. In this case, most customers have to raise their voices to hear each other. At 75 dB, the conversation is difficult and at 85 dB, damaging. It only takes several tables of people talking loudly to push the ambient noise levels up to uncomfortable levels.

As the current fashion is for restaurants and coffee houses to have minimalist interior design, eschewing an industrial theme, so the room is filled with hard surfaces. Wooden floors, brick walls, open and exposed heating or ventilation systems, bare tables, uncushioned chairs - and so it goes on. Each one of these surfaces is reflective to sound waves.

In everyday life, people's habits also change. Young people tend to listen to music through headphones more frequently. Even though there are warnings about the damage that the increase of sound level can cause, these warnings are often ignored. Rock concerts, night clubs and music festivals generate noise intensity of up to 100 dB, which most certainly results in adverse consequences. Also, population increase and migrations to urban areas increase environment noise in big cities [2]. That kind of lifestyle produces a negative cumulative effect of noise which damages not only hearing but also overall health. For instance, over the years the increase in the growth rate of hearing loss is evident [3].

Lots of studies have shown that presently noise is one of the leading problems in the environment and the second-largest environmental cause of health problems [4]. The majority of the population in cities constantly complains about traffic and street noise, loud music or about some other source of irritable

sounds. People react differently to noise, but generally, noise has a negative impact on human health. It increases anxiety, damages hearing, and it also causes cardiovascular and other diseases [5] and disturbs body immune response [6].

MATERIAL AND METHODS

Measurements of noise were conducted in four food courts and coffee houses at the University of Novi Sad at a time when they were crowded, usually between 11 AM and 1 PM. The noise level was measured using the TES-1358A Sound Level Meter (SLM), with RS-232 Interface. The calibration procedure of the instrument was performed before the actual measurements using a standard acoustic calibrator recommended by SLM manufacturer (TES Electrical). The desired response of SLM was set at "fast". When the measurements were made, the microphone was located in such a way as not to be in the acoustic shadow of any obstacle in the appreciable field of reflected waves. Noise levels were measured at the position of the customers' head. The direction of SLM was towards the source of the sound. For conducting the noise survey, Serbian guidelines for noise measuring were followed [7]. The A-weighted levels on L_{eq} , L_{max} and L_{min} Sound Pressure Level (SPL) in dB(A) were collected. L_{eq} is the equivalent continuous noise level which at a given location and over a given period of time contains the same A-weighted sound energy as the actual fluctuating noise at the same location over the same period [1].

The noise levels were measured over a period of one hour. The measurements were repeated three times and the average level of noise levels were taken as the measurements' result. At the end of the experiment, the data were downloaded to a personal computer. With the help of utility software, the equivalent SPL at each reading was obtained. The data were statistically analyzed using Microsoft Excel and SPSS package.

RESULTS AND DISCUSSION

One of the major problems in the hospitality sector is the problem of noise during their opening hours. The main sources of noise in restaurants and similar facilities are conversations between humans and music as well as the operation of various ventilation and cooling systems. In view of these facts, the present research was conducted to analyze the impact of noise on customers (service users) in coffee houses.

The noise was measured in four food courts and coffee houses on the campus of the University of Novi Sad, and a survey of service users in these facilities gave the following results: out of a total of 89 respondents, 50 (56%) were women and 39 (44%) male. Table 1 shows the number of respondents by age groups, indicating that the largest number of respondents aged between 21 and 25 (48%), while other groups were represented in a smaller percentage.

Table 1. Respondent age groups

Age	Number of respondents	Percentage
Younger than 20	15	16.9
21-25	53	59.6
25-30	12	13.5
30-35	4	4.5
35-40	1	1.1
Older than 40	4	4.5
Total	89	100.0

The results of noise measurements are given in Table 2. The lowest value of equivalent noise (L_{Aeq}) as measured in facility II (66.2 dB (A)), and the highest in the facility IV (76.3 dB (A)). According to Serbian legislation on noise in the environment, the permissible noise level in restaurants during the day and evening is 60 dB, and during the night 50 dB, while for the same facilities within the University campus the permissible noise level during the day and evening is 40 dB [7]. Comparing the

measured values with those prescribed by law, it can be seen that the noise levels exceed the allowed values in all four facilities. Similar research has been conducted in various cities around the world. For example, the measured noise level in Chinese restaurants in Hong Kong ranged from 67.6 to 79.3 dBA, and in fast-food restaurants the values ranged from 69.1 to 79.1 dB (A). In a study of 27 restaurants in San Francisco, Lebo et al. found that the mean equivalent noise level in restaurants was 71 dB (A) [9].

Table 2. Measured values of L_{eq} , L_{max} and L_{min}

Facility	L_{Aeq} [dB(A)]	L_{Amax} [dB(A)]	L_{Amin} [dB(A)]
I	73.4	83.4	67.0
II	66.2	72.5	59.0
III	67.2	75.6	59.4
IV	76.3	81.2	71.4

Based on surveys on the psychophysical effects of noise on respondents (Table 3), the following conclusions can be drawn:

- The largest number of service users (42%) in these facilities assesses their exposure to noise in everyday activities with a score of 3.0 (question group Q1, Table 4), i.e. they do not have an opinion regarding the stated findings. The results of this survey follow a normal distribution.
- The impact of noise in occasional activities was rated 4.0 (question group Q2, Table 4) by half of the respondents (51%). It was noticed that the respondents, in this group of questions, visit concerts, festivals, and, generally, places with an increased value of noise.
- On questions related to psychological effects (question group Q3, Table 4), the average score of one third of the respondents (35%) is 2.0 which means that the respondents believe that the presence of noise does not cause them anxiety, stress, hypertension, insomnia or headaches.

Table 3. Respondents' exposure to noise in daily and occasional activities and psychological effects of noise

	Grade value	1	2	3	4	5
Noise exposure in daily activities	Number of respondents	3	22	37	25	2
	Percentage	3%	25%	42%	28%	2%
Noise exposure in occasional activities	Number of respondents	0	3	38	45	3
	Percentage	0%	3%	43%	51%	3%
Psychological effects as a consequence of noise	Number of respondents	18	31	24	13	3
	Percentage	20%	35%	27%	15%	3%

Table 4. Respondents' perception of the effects of noise on the guests in restaurants and similar facilities on UNS campus

Q1.1	You live in a part of the city where you are exposed to traffic noise.	1*	2*	3*	4*	5*
Q1.2	You are bothered by the noise you are exposed to in your environment.	1	2	3	4	5
Q1.3	Do you have a TV or radio on in the background during everyday activities?	1	2	3	4	5
Q1.4	Do you like listening to loud TV or radio?	1	2	3	4	5
Q1.5	You use headphones when listening to music.	1	2	3	4	5

Q2.1	You go out to places where loud music is played.	1	2	3	4	5
Q2.2	You attend music festivals/concerts.	1	2	3	4	5
Q2.3	When going to a festival/concert, you choose a place closer to the stage.	1	2	3	4	5
Q2.4	Do you feel any discomfort after the festival/concert such as tinnitus, headache, etc.	1	2	3	4	5
Q2.5	Do you prefer quieter places when choosing where to sit in a cafe?	1	2	3	4	5
Q2.6	Do noisy cafes interfere with your communication with other people?	1	2	3	4	5
Q2.7	You are more bothered by the noise produced by people than by music in cafes.	1	2	3	4	5
Q3.1	Have you noticed that the loud environment makes you anxious?	1	2	3	4	5
Q3.2	Have you notices that a loud environment causes you stress?	1	2	3	4	5
Q3.3	Have you noticed that a loud environment increases your blood pressure?	1	2	3	4	5
Q3.4	Have you noticed that a loud environment causes you insomnia?	1	2	3	4	5
Q3.5	Have you noticed that a loud environment gives you a headache?	1	2	3	4	5

- 1* I completely disagree
- 2* I disagree
- 3* I neither agree nor disagree
- 4* I agree
- 5* I completely agree

Figure 1 shows that the negative psychological effects of noise are most pronounced in the respondents in the age group between 30 and 35 (mean score 3.5) and those over 40 (mean score 3.15).

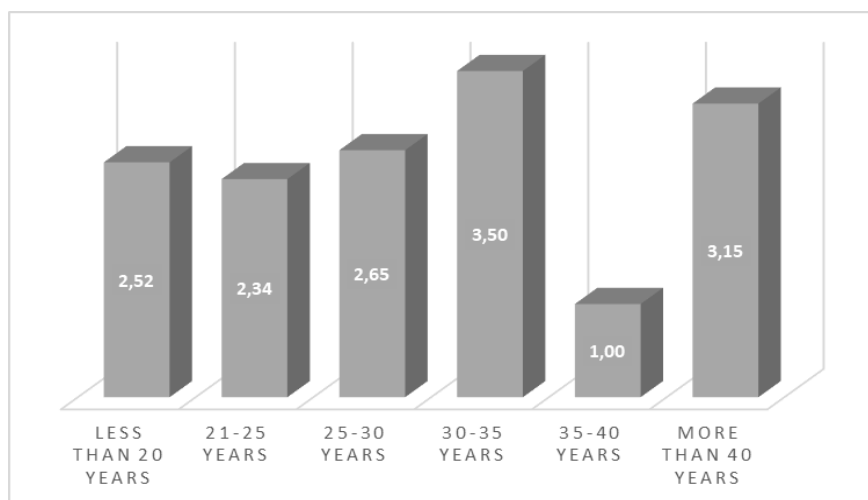

Fig. 1. Respondents' evaluation of the psychological effects of noise with respect to age (mean values)

CONCLUSION

Noise measurements were performed in four food courts and coffee houses on the campus of the University of Novi Sad. The values obtained were in the range of 66.2 - 76.3 dB (A). No measurement exceeded the value of 80 dB (A), which is the limit above which, due to permanent exposure, hearing impairment occurs. The obtained results showed that the noise within all premises exceeds the allowed limits prescribed by the rulebook on noise regulation in the Republic of Serbia [7]. The analysis of the responses of service users in these facilities showed that noise causes more pronounced psychological effects in men than in women and that the greatest negative impact of noise (in terms of psychological effects) was on the age groups between 30 and 35 over 40 years of age. Based on the obtained results, it can be concluded that appropriate changes should be made in the interior of the facilities in order to improve the acoustic performance of the space. This would reduce the noise level on the premises and its harmful effects on both employees and customers.

ACKNOWLEDGEMENT

This research (paper) has been supported by the Ministry of Education, Science and Technological Development through the project no. 451-03-68/2020-14/200156: "Innovative scientific and artistic research from the FTS (activity) domain".

REFERENCES

- [1] NIOSH "NIOSH criteria for a recommended standard: occupational exposure to noise," Cincinnati, OH: U.S. Department of Health, Education, and Welfare, Public Health Service, Center for Disease Control, National Institute for Occupational Safety and Health, DHSS - NIOSH- Publication No. 98-126, 1998.
- [2] Hunashal R.B., Patil Y.B.,(2012). *Assessment of Noise Pollution Indices in the City of Kolhapur, India*, *Procedia - Soc. Behav. Sci.*, **7**, 448 – 457, <https://doi.org/10.1016/j.sbspro.2012.03.310>, 2012.
- [3] Sliwinska-Kowalska M., (2015), *Hearing, Handb. Clin. Neurol.*, **131**, 341–363. <https://doi.org/10.1016/B978-0-444-62627-1.00018-4>, 2015.
- [4] World Health Organization, *NIGHT NOISE GUIDELINES FOR EUROPE*, Edited by Charlotte Hurlley: 2009, ISBN 978 92 890 4173 7, 2009.
- [5] Davies, H. W., Teschke, K., Kennedy, S. M., Hodgson, M.R., Hetzman, C., et al. (2005). Occupational exposure to noise and mortality from acute myocardial infraction. *Epidemiology*, **16** (1), 25-32., 2005.
- [6] Iyyanki V. Murali Krishna, Valli Manickam, *Noise Pollution and Its Control*, Environmental Management, 2017, ISBN 978-0-12-811989-1Balat, M., *Prospects for Worldwide Biodiesel Market Development, Energy Sources, Part B: Economics, Planning, and Policy*, No.4., pp. 48 – 58, 2009.
- [7] Vlada Republike Srbije, "Uredba O Indikatorima Buke, Graničnim Vrednostima, Metodama Za Ocenjivanje Indikatora Buke, Uznemiravanja I Štetnih Efekata Buke U Životnoj Sredini," 2010.
- [8] W. M. To, "Noise in restaurants: Levels and mathematical model," *Noise Heal.*, pp. 368–373, 2014.
- [9] Lebo, C. P., Smith, M. F. W., & Mosher, E. R. (1994). Restaurant noise, hearing loss, and hearing aids. *Western Journal Medicine*, 45–49., 1994.

ASSESSMENT OF METHANE ENERGY RECOVERY POTENTIAL FROM THE MUNICIPAL SOLID WASTE LANDFILL OF ZRENJANIN

Una Marčeta¹, Bogdana Vujić¹, Višnja Mihajlović¹, Jelena Mičić²

¹University of Novi Sad, Technical Faculty “Mihajlo Pupin”, Zrenjanin, Serbia

²Faculty of Technical Sciences, Novi Sad

e-mail: una.tasovac@tfzr.rs

Abstract: Landfilling is the most widely used method for municipal solid waste disposal which is the cause of greenhouse gases (GHG) emissions. LandGEM modeling software was used to calculate the methane emissions levels from Zrenjanin landfill. Energy recovery potential from methane generation on Zrenjanin landfill was found to vary from $1.71 \cdot 10^8$ MJ/yr to $1.07 \cdot 10^8$ MJ/yr, and the amount of generated electricity (kWh) from $4.75 \cdot 10^7$ kWh to $2.97 \cdot 10^7$ kWh. Energy recovery from landfill gas could provide environmental and economic benefits.

Key words: methane, landfill gas, energy recovery

INTRODUCTION

Municipal solid waste management in an appropriate manner is crucial in order to prevent the negative impact of waste on the environment [1],[2]. Waste management policy priorities in the European Union (EU) are waste disposal, energy recovery, recycling, reuse and prevention of waste generation [3].

In developed countries, the concept of sanitary landfill is applied, while low-income countries most often face the problem of environmental degradation due to waste disposal in uncontrolled or partially controlled landfills. Although unsanitary waste management does not involve high costs, on the other hand, it implies huge negative impacts on the environment: unpleasant odors, dust, noise, the possibility of groundwater pollution and air pollution due to landfill gas emissions [4],[5],[6].

One of the main objectives of the Landfill Directive is to reduce the amount of biodegradable waste in landfills through separate collection, composting, biogas production or reuse and recycling. In Serbia, almost all organic waste ends up in mostly unsanitary landfills, although the Landfill Directive adopted in 2010 prescribes clear targets for the amount of biodegradable waste deposited.

After disposal at landfills, municipal solid waste goes through several chemical reactions. Organic fractions of waste are subject to biochemical decomposition under anaerobic conditions, which results in the formation of landfill gas. Landfill gas consists primarily of carbon dioxide (CO₂) and methane (CH₄), including some trace components such as nitrogen, oxygen, ammonia, sulfides, hydrogen, carbon monoxide, and nonmethane organic compounds [7].

Carbon dioxide and methane are considered to be the most significant greenhouse gases present in the atmosphere, whereby CH₄ has 28 times greater global warming potential. In addition, its retention period in the atmosphere is 12 ± 3 years. The most common risks to human health and the environment associated with landfill gas are explosions, asphyxia, toxicity, odors, and gas emissions that contribute to global warming [8].

One of the acceptable ways of dealing with municipal waste is its disposal with landfill gas recovery as an energy source. In this way, controlling emissions and reducing negative impacts on the environment are achieved [9].

MATERIAL AND METHODS

Description of the landfill site

The city of Zrenjanin is located on the territory of central Banat and according to data from 2011, the number of inhabitants is 170,013, and the annual production of waste per capita is 341.4 kg / year. In Zrenjanin, almost 100% of the collected waste is disposed of in landfills without prior treatment, with the exception of PET packaging waste which separation has been organized since 2006. The official

waste disposal site for city Zrenjanin is located on the southwest side of the settlement and it is about 5 km away from the center of Zrenjanin. Zrenjanin landfill started operating in 1984, it occupies an area of about 35 ha and about 50% of the area is covered with waste. Compaction and spreading of waste material is performed on the landfill, as well as partial covering with inert material [10].

At Zrenjanin landfill there is about 700,000 m³, ie. 490,000 tons of municipal waste. There are 40 unconnected biothorns on the landfill, from which the landfill gas is passively evacuated into the atmosphere, without incineration or energy recovery [11], [12].

Estimation of methane emissions

LandGEM 3.02 modeling software was used to calculate the gas emissions levels from Zrenjanin landfill. This model is a function of two model parameters, methane production potential and first-order decay rate which is associated with waste decomposition (yr⁻¹), as shown in Eq. 1 [13],

$$Q_n = kL_0 \sum_{i=0}^n \sum_{j=0.0}^{0.9} \frac{M_i}{10} e^{-kt_{ij}} \quad (1)$$

where Q_n is CH₄ generation rate (m³ yr⁻¹) in year n ; k is first-order waste decay rate (yr⁻¹); L_0 is the CH₄ generation potential (m³ Mg⁻¹ wet waste); M_i is the waste mass placement in year i (Mg); j is and intra-annual time increment used to calculate CH₄ generation; and t is time (yr).

Energy generation potential from methane

In order to assess methane energy recovery potential LandGem model was used to predict mass (Mg) and volume (m³) of the CH₄ emissions. The amount of methane emitted (m³) were used to estimate the amount of energy (MJ) produced considering 70% collection efficiency and the amount of electricity (kWh) generated taking the efficiency of gas engine as 30% and lower heating value (LHV) of methane as 35 MJ/m³. Therefore, electrical potential estimation was calculated with the assumption of 1 m³ methane is equal with 35 MJ [14], [15], [16].

RESULTS AND DISCUSSION

The potential electricity produced from methane and its contribution to electricity consumption was estimated for two oxidation factors. In the first case Influence of methane oxidation variation in soil cover is assessed with 0.2 and in the second case with 0.5 oxidation factors. Given that there are no official data on previous waste amount on researched landfill, waste generation rate kg capita⁻¹yr⁻¹ was used as a constant.

Taking into account LandGEM predicted methane emission in 2019, oxidation factors and collection efficiency, the estimated amount of methane collected in the first case would be 3.261* 10³ Mg or 4.888 * 10⁶ m³ and in the second case 2.04* 10³ Mg or 3.06 * 10⁶ m³.

Energy recovery potential from methane generation on Zrenjanin landfill in the first case it is estimated at 1.71 * 10⁸ MJ/yr and in the second case at 1.07 * 10⁸ MJ/yr.

Further, the electricity equivalent (kWh) was calculated for both cases based on the values of energy, so for the year 2019 value of electricity equivalent (kWh) for the Zrenjanin landfill was found to be 4.75 * 10⁷ kWh (first case) and 2.97 * 10⁷ kWh (second case).

CONCLUSION

One of the biggest problems of biodegradable waste disposal is the emission of landfill gas, considering that greenhouse gases (methane and carbon dioxide) have the largest share in its composition. Waste disposal at unsanitary landfills leads to emission of large amounts of methane into the atmosphere. In developing countries such is a Serbia, the problem of waste disposal is still unresolved, so there are mostly unsanitary and unregulated landfills. Results of this study indicates that by energy recovery from landfill gas we can reduce the greenhouse gas emission on the one hand, and get a local source of energy for the other hand.

REFERENCES

- [1] Ghiani G, Laganà D, Manni E, Triki C. 2012. Capacitated location of collection sites in an urban waste management system. *Waste Management* 32:1291–1296. doi:10.1016/j.wasman.2012.02.009
- [2] Arrieta G, Requena I, Toro J, Zamorano M. 2016. Adaptation of EVIAVE methodology for monitoring and follow-up when evaluating the environmental impact of landfills. *Environmental Impact Assessment Review* 56:168–179
- [3] Minelgaitė A, Liobikienė G. 2019. Waste problem in European Union and its influence on wastemanagement behaviours. *Science of the Total Environment* 667:86–93
- [4] Di Felice P. 2014. Integration of Spatial and Descriptive Information to Solve the Urban Waste Accumulation Problem. *Procedia - Social and Behavioral Sciences* 147:182 – 188. doi: 10.1016/j.sbspro.2014.07.150
- [5] Han D, Tong X, Currell MJ, Cao G, Jin M, Tong C. 2014. Evaluation of the impact of an uncontrolled landfill on surrounding groundwater quality, Zhoukou, China. *J Geochem Explor* 136:24–39
- [6] Alam A, Tabinda AB, Qadir A, Butt TE, Sidra Siddique S. 2017. Ecological risk assessment of an open dumping site at Mehmood Booti Lahore, Pakistan *Environ Sci Pollut Res* 24:17889–17899 DOI 10.1007/s11356-017-9215-y
- [7] UNS FTN. 2008. Studija mogućnosti korišćenja komunalnog otpada u energetske svrhe (Waste To Energy) na teritoriji Autonomne Pokrajine Vojvodine i Republike Srbije. Pokrajinski sekretarijat za energetiku i mineralne sirovine Autonomne Pokrajine Vojvodine, Fakultet tehničkih nauka, Departman za inženjerstvo zaštite životne sredine, Novi Sad.
- [8] IPCC 2013. Stocker, T.F., Qin, D.H., Plattner, G.K., Tignor, M.M.B., Allen, S.K., Boschung, J., Nauels, A., Xia, Y., Bex, V., Midgley, P.M. *Climate Change 2013: the Physical Science Basis. Contribution of Working Group I to the Fifth Assessment Report of the Intergovernmental Panel on Climate Change.* Cambridge University Press, Cambridge, United Kingdom and New York, NY, USA
- [9] Yucekaya A. 2014. Landfill Gas to Energy in Turkey: Current and Future. *Journal of Science and Technology*, 2: 1
- [10] Maja Djogo, Nivoi koncentracija i upravljanje perzistentnim organskim polutantima u heterogenom sistemu deponija komunalnog otpada, doktorska disertacija, Novi Sad, 2017.godine
- [11] Dejan Jovanov, Model optimizacije monitoring deponijskog gasa i procedne vode na zatvorenim deponijama, doktorska disertacija, Novi Sad, 2016.godine
- [12] Vujić Goran, 2009. Glavni projekat sanacije, rekultivacije i zatvaranja deponije u Zrenjaninu, Fakultet tehničkih nauka, Univerzitet u Novom Sadu
- [13] USEPA (2005) Landfill Gas Emissions Model (LandGEM) Version 3.02 User's Guide, EPA-600/R-05/047 U.S. Environmental Protection Agency, Office of Research and Development and Clean Air Technology Center.
- [14] S Suhartini, Y P Lestari and I Nurika - Estimation of methane and electricity potential from canteen food waste, Suhartini et al 2019 IOP Conf. Ser.: Earth Environ. Sci. 230 012075
- [15] Evaluation of energy potential of Municipal Solid Waste from African urban areas N. Scarlat , V.Motola, J.F.Dallemand, F.Monforti-Ferrario, Linus Mofor, *Renewable and Sustainable Energy Reviews* 50(2015)1269–1286
- [16] Assessment of methane emissions and energy recovery potential from the municipal solid waste landfills of Delhi, India Pooja Ghosh, Goldy Shah, Ram Chandra, Shivali Sahota, Himanshu Kumar, Virendra Kumar Vijay, Indu Shekhar Thakur, *Bioresource Technology* 272 (2019) 611–615

IMPACT OF COVID-19 PANDEMIC CRISIS ON ENVIRONMENTAL PROTECTION EXPENDITURES OF LOCAL SELF GOVERNMENTS IN SERBIA

Nedeljko Ćurić¹

¹Standing Conference of Towns and Municipalities, Belgrade, Serbia
e-mail: nedeljko.curic@gmail.com

Abstract: Starting from March 2020 the working and living conditions in Serbia dramatically changed due to the Covid-19 Pandemic crisis. International Labour Organization and European Bank for Reconstruction assessed of the Employment Impact and Policy Responses in Serbia the coronavirus pandemic has hit micro enterprises in Serbia hardest and led to a decline in working hours during the second quarter of 2020 equivalent to the loss of 510,000 full-time jobs. Considering that significant part of LSGs in Serbia incomes comes from salaries' taxes, it is need to analyze the impact of Covid-19 pandemic on environmental protection in Serbia considering that development in that sector is under LSGs direct responsibilities. So, how the Covid-19 pandemic crisis affected to the Local Self Governments' in Serbia expenditures on environmental protection?

Key words: Covid-19 impact, programme budgeting, environmental protection

INTRODUCTION

The COVID-19 pandemic is a crisis like no other. It feels like a war, and in many ways it is. People are dying. Medical professionals are on the front lines. Those in essential services, food distribution, delivery, and public utilities work overtime to support the effort. And then there are the hiddensoldiers: those who fight the epidemic confined in their homes, unable to fully contribute to production [1].

Considering that the topic of this paper is impact on Covid-19 Pandemic crisis on Local SelfGovernments' expenditures from its budgets on environmental protection, and the fact that majority of incomes comes from salaries' taxes (in the cities more than 41% while in the municipalities 25%), the main Serbian State measures on people's income will be presented: The lockdown in Serbia was strict. The authorities enacted several measures to facilitate remainat home and social distancing, including general requirements for workplace closures, curfews, restrictions on gatherings and movement within the country, border closure and mandatory quarantine. The containment measures during the state of emergency gradually deepened, with permanent lockdown for the elderly (65+), who were later allowed to leave their homes only between 4 a.m. and 7 a.m.; 84 hours of complete lockdown during major holiday weekends (Easter, Labor Day and soon); and 12 hour-long curfews between 5 p.m. and 5 a.m. From a labor market perspective, informality and the incidence of rural work may have mitigated the lockdown's stringency for certain categories of workers. By the first week of May, the country had begun to lift the lockdown gradually.

COVID-19 Containment measures adopted

Measures to contain movement: State of emergency declared on the 15th of March 2020 (lifted on the 6th of May 2020, election-related activities postponed until after state of emergency). School and workplace closures: Schools closed since the 15th of March. Online classes were held for the rest of the school year. Kindergartens closed on the 15th of March and re-opened (partially) on the 11th of May. All but essential shops closed until the 21st April when shops that offer services (for example, car mechanics, tailors) are allowed to re-open again. Restrictions on events and gatherings: All public gatherings banned between the 15th of March and the 6th of May. May and June: outdoor gatherings are allowed and indoor gatherings are limited to 500 persons. Since early July: all public gatherings limited to 10 persons.

As of the 3rd of August 2020, the following sets of policy measures had been adopted in Serbia. Support for specific sectors, enterprises and employment retention Support for specific sectors. All medical staff received a 10 per cent wage increase from April 2020. Ban on export of medicines for 30

days from 15 March. One-off assistance for hotels (EUR 500 per single room and EUR 850 per double room) provided that they do not lay off more than 10 per cent of the workforce until December 2020 (cost: RSD 1.25 billion or approximately EUR 10.7 million). Support for enterprises and business continuity: Favorable loans for liquidity were approved for 10,000 MSMEs, farms and cooperatives. Three-month moratorium on the payment of housing and other loans introduced for a three-month period, ending on the 1st of July 2020. As of August, deferral of payment of social security contributions and payroll tax for one month. Employment retention measures: Doctors and nurses who volunteered during the pandemic were provided with full employment.⁸⁸ More than 1 million employees in 232,000 enterprises received the minimum wage (~ 275 USD per month) in May, June and July and 60 per cent of the minimum wage in August. Employees in public sector were guaranteed not to be laid-off and to retain their full salary. All employees in medium and large private enterprises who were laid off during the state of emergency will be paid 50 per cent of their monthly wages. Worker protection measures Unemployment benefits and social protection. One-off payment was given to all pensioners to buy basic hygiene and food products [2]. Starting from 2015 Local Self Governments (LSG) in Serbia are obliged to plan budget expenditures per the following programmes (with number of programme activities) are defined [3]:

- Programme 1: Housing, Urban and Spatial Planning
- Programme 2: Communal Service
- Programme 3: Local Economic Development
- Programme 4: Tourism Development
- Programme 5: Agriculture and Rural Development
- Programme 6: Environmental Protection
- Programme 7: Traffic Organization and Traffic Infrastructure
- Programme 8: Preschool Education
- Programme 9: Primary Education
- Programme 10: Secondary Education
- Programme 11: Social and Child Care
- Programme 12: Health Care
- Programme 13: Culture Development and Information
- Programme 14: Sport and Youth Development
- Programme 15: Local Self Government Public Service
- Programme 16: Local Self Government Political System
- Programme 17: Energy Efficiency and Renewable Energy Sources

MATERIAL AND METHODS

The methodology is based on the collecting of data on LSGs incomes and expenditures achieved and planned, for the following periods: I-VI and I-XII of 2019, I, I-II, I-III, I-IV, I-V, I-VI of 2020 (Data were collected in the Standing Conference of Towns and Municipalities, Belgrade, from May up to August 2020). The data is presented by functional, economic and programme classification. The focus of this analysis is on data on the following programmes related to environmental protection under jurisdiction of LSGs [3]: Communal Service (Programme 2), Programme 6 (Environmental Protection) and Programme 17 (Energy Efficiency and Renewable Energy Sources). Also, economic classification will be considered as well - the count 511 connecting expenditures of the following project cycles phases as per Decree [4]: Pre-implementation (identification, preparation, revision, selection) and Implementation phases. 107 LSGs sent data but only 56 of them sent data on all periods, which therefore presents the basis for this analysis. Data of the City of Belgrade, are not included, considering that Belgrade's incomes in the first six months of 2020 contributes in 30.5% of total budget incomes of all LSGs in Serbia (145) and 29.0% of all expenditures [3]. Received data from 56 LSGs present 56% of sum of all LSGs' budget for 2019 (without Belgrade) and 36.06% with Belgrade, covers 43.61% of territory without Belgrade and 41.78% with Belgrade and includes 52.14% inhabitants without Belgrade and 39.48% with Belgrade. Also, LSGs from all parts of Serbia are presented, proportionally, so the sample can be considered as representative (without Belgrade).

RESULTS AND DISCUSSION

In the following charts present the gathered data in order to set data for the discussion and conclusion.

The impact of Covid-19 on Serbian LSGs incomes and expenditures

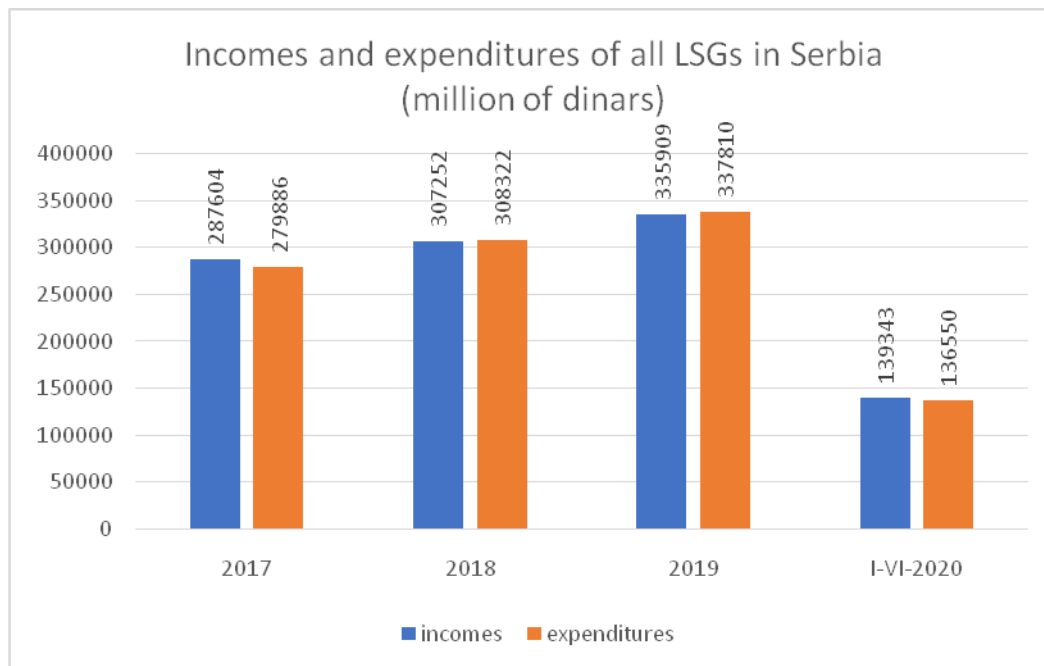

Fig. 1. Incomes and expenditures of all LSGs in Serbia (million of dinars) [5]

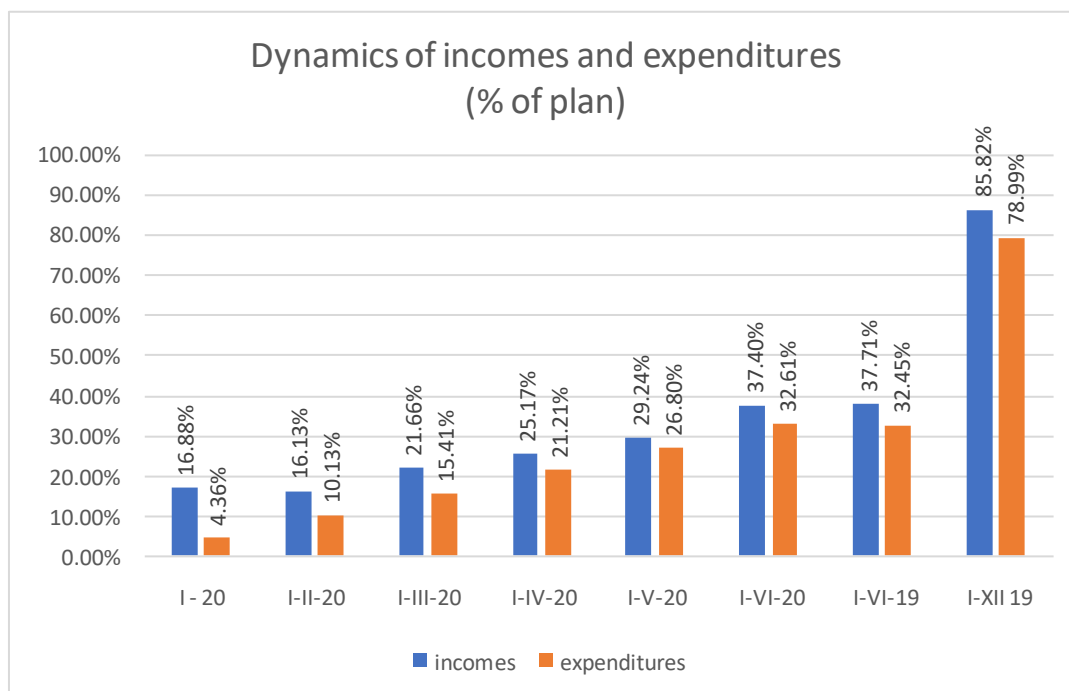

Fig. 2. Dynamics of incomes and expenditures for selected LSGs per periods (% of the plan achievements)

Data from the Charts 1 and 2 shows that although the level of plan achievements in the first six months of 2020 reached the level from 2019, it should be larger considering the expected increasing at minimum level of approx. 6%, leads to the conclusion of stagnation of incomes in the selected LSGs caused by Covid-19 Pandemic.

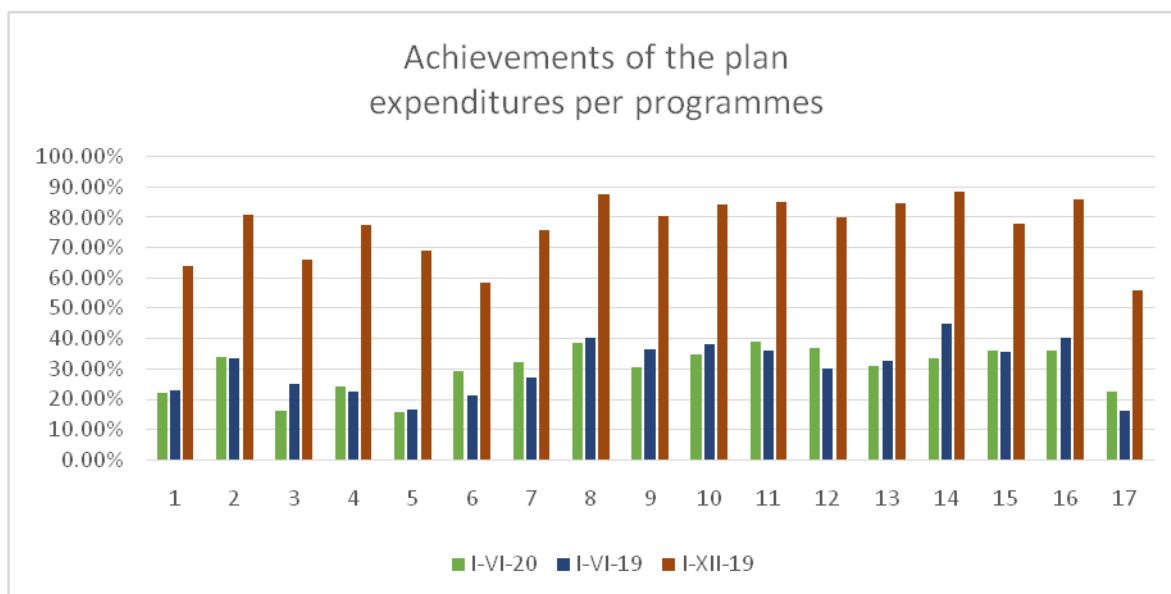

Fig. 3. Achievements of the plan expenditures per all budget programmes (%)

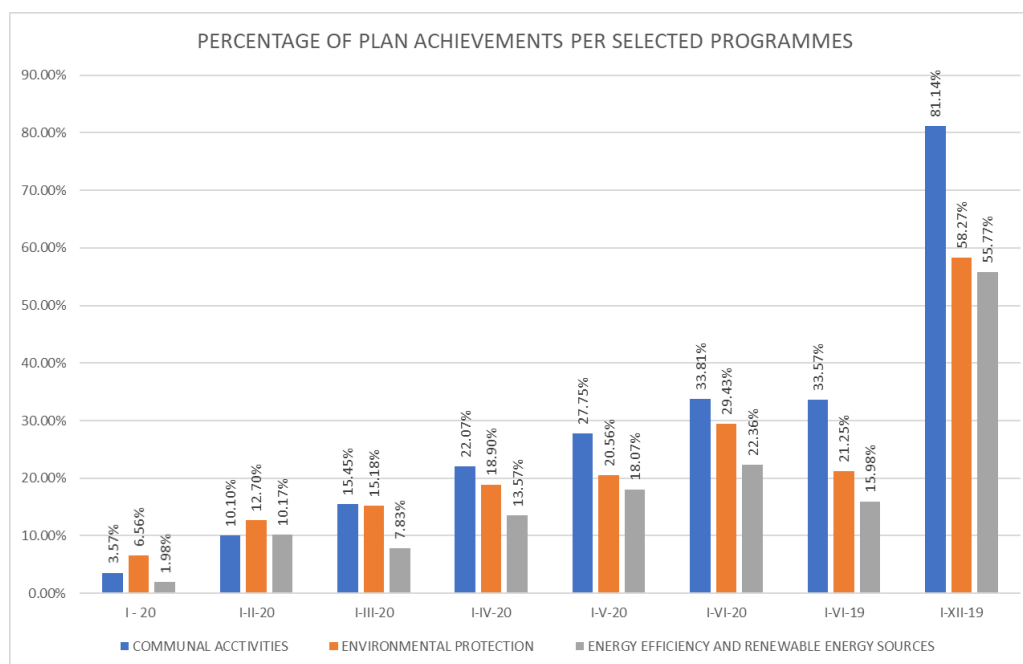

Fig. 1. Achievements of the plan expenditures per selected budget programmes (%)

According to the data from Charts 3 and 4 it is visible that achievement of the plan significantly lagging behind in the following programmes: Local Economic Development (3), Primary Education (9), Secondary Education (10), Sport and Youth Development (14), while in the sector Communal Service (2) is on the same level as for the first six months of 2019. In programmes Environmental Protection (6) and Efficiency and Renewable Energy Sources (17) there are even higher than in the same period of last year ensuring positively expectation to achieve the same level by the end of the year.

However, those indicators should be justified by in depth analysis of the type of investments in the targeted programmes which is show in the following charts.

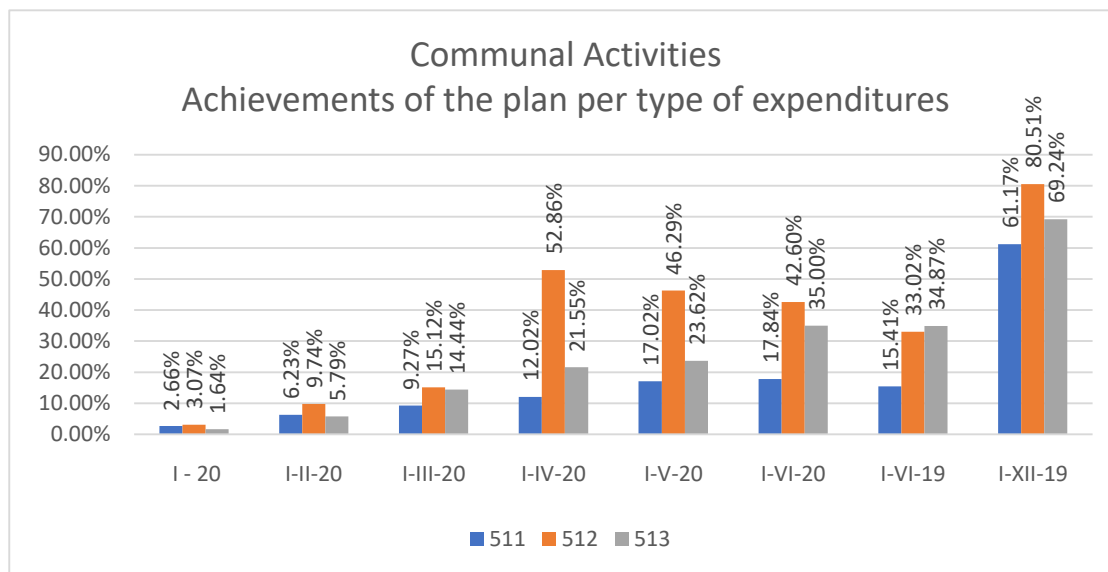

Fig. 5. Achievements of the plan expenditures per programme Communal Activities-2 (%)

Programme Communal Activities covers following competencies of Local Self Governments:

- Public lighting
- maintenance of public green areas
- maintaining cleanliness in public areas
- zoohygiene
- Maintenance of green markets
- cemetery maintenance and funeral services
- Production and distribution of thermal energy
- Management and supply of drinking water

According to the graph 3 it is visible that by measuring the percentage of the plan achievement in the selected LSGs, investment in constructing of premises (account 511) slightly decreased while investment in machinery (account 512) increased and investment in other assets (including leasing) increased, too.

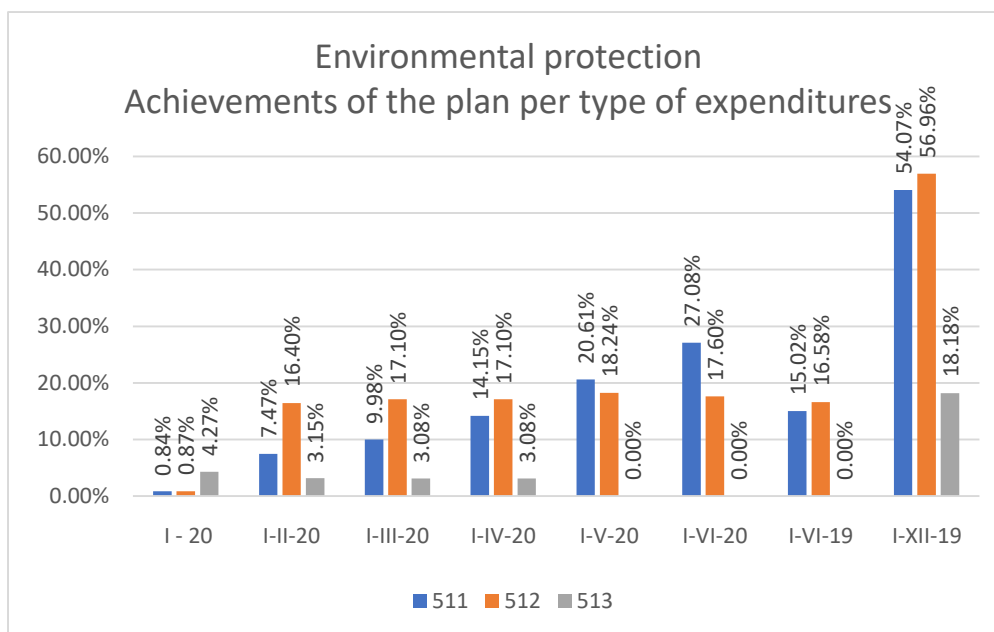

Fig. 6. Achievements of the plan expenditures per programme Environmental Protection-6 (%)

Programme Environmental Protection covers following competencies of Local Self Governments:

- Environmental protection management,
- Monitoring the quality of environmental elements
- Nature protection,
- Waste water management,
- Communal Solid Waste management,
- Management of the other type of communal waste

Considering Environmental Protection, it is shown that by measuring the percentage of the plan achievement in the selected LSGs, investment in constructing of premises (account 511) decreased – looks even naturally with expectations to be achieved at the level as it was in last year. Investments in machinery and equipment (account 512) seem stable and even slightly higher than in the first half year of 2019. Finally, investment in other assets (including leasing) significantly decreased as it was in the first six months last year.

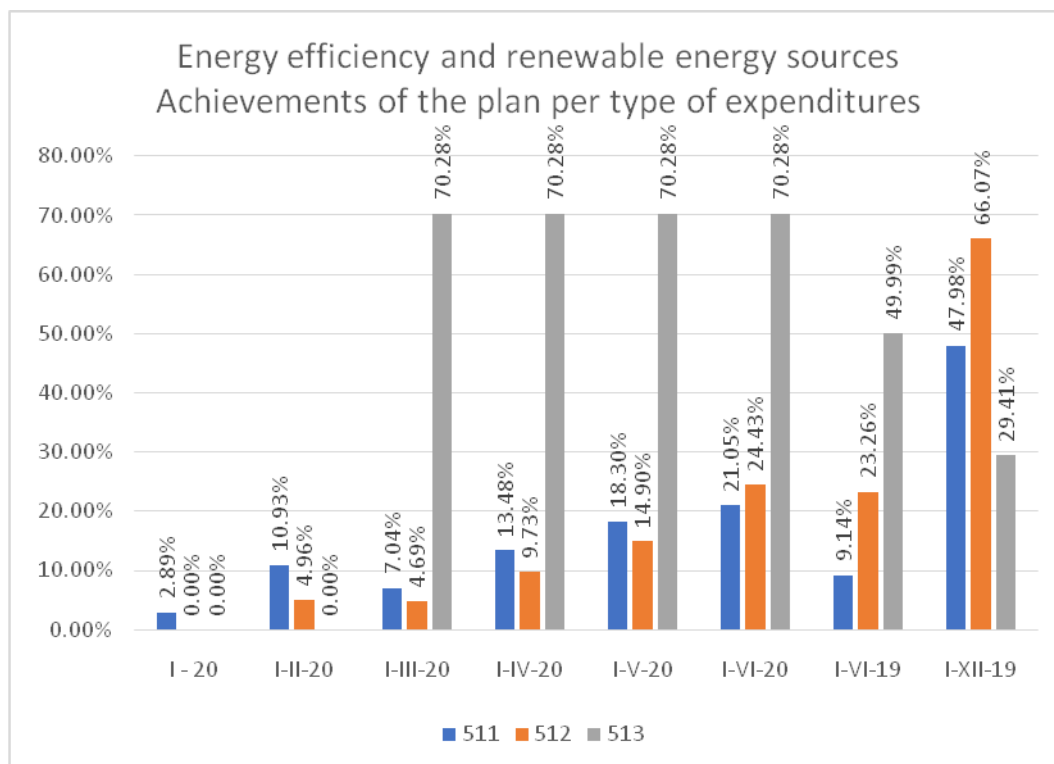

Fig. 7. Achievements of the plan expenditures per programme Energy Efficiency and Renewable Energy Sources-17 (%)

Programme Energy Efficiency and Renewable Energy Sources covers sustainable energy development through encouragement, energy infrastructure improvement and whither usage of renewable energy sources. Related to this programme, it is shown that by measuring the percentage of the plan achievement in the selected LSGs, investment in constructing of premises (account 511) decreases in 2020 achieving significantly higher level in the first six months of 2020 comparing with the same period of 2019. Investments in machinery and equipment (account 512) seem stable and slightly higher than in the first half year of 2019. Finally, investment in other assets (including leasing) significantly decreased in March 2020 and seems stable in the whole period and is significantly higher than in whole 2019. For sure, those data have to be re-evaluated by the end of the year, especially considering that those expenditures were less by the end of 2019 comparing its level in first six months.

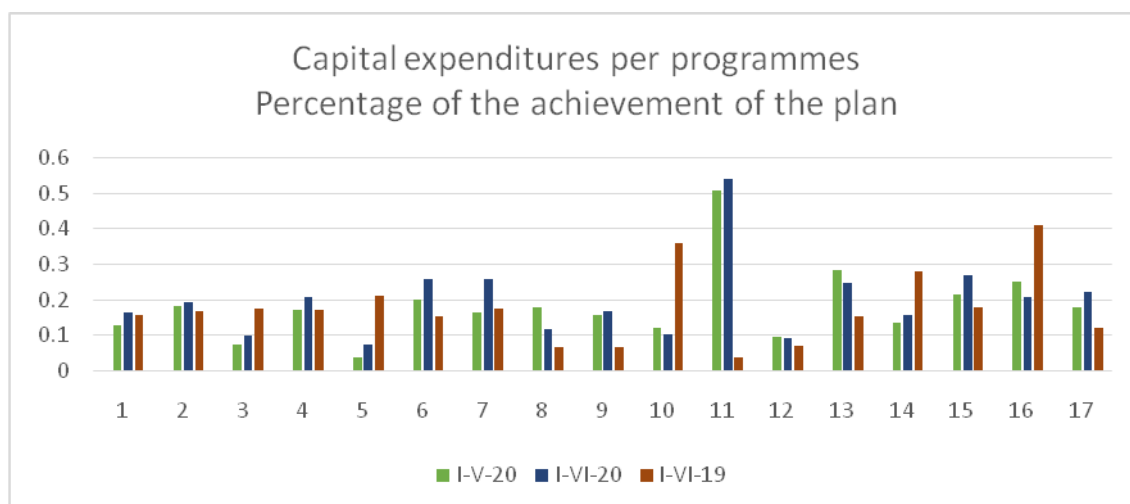

Fig. 8. Capital expenditures per budget programmes (%)

CONCLUSION

Although the income of LSGs in Serbia has decreased by approx 10 percent in the first six months of 2020 comparing with the first six months of 2019, in the selected LSGs the expenditures related to environmental protection staid stabile and even inxreased in the same period. The less income were compensated by less needs and expednitures in the programmes of Elementary, Secondary school, Sport. From the other side The coronavirus pandemic has hit micro enterprises in Serbia hardest and led to a decline in working hours during the second quarter of 2020 equivalent to the loss of 510,000 full-time jobs. However, offering “the most generous and comprehensive economic package among the Western Balkan economies,” the Serbian government successfully contained “the expansion of poverty”, according to a new report by the European Bank for Reconstruction and Development (EBRD) and the International Labour Organization (ILO), published today[1]. Considering that Covid-19 pandemic will last by the end of this year, it is still need at LSGs level to manage its finances with greater care.

REFERENCES

- [1] Internet source: International Monetary Fund, Economic Policies for the COVID-19 War APRIL 1, 2020 https://blogs.imf.org/2020/04/01/economic-policies-for-the-covid-19-war/?utm_medium=email&utm_source=govdelivery
- [2] COVID-19 and the World of Work Rapid Assessment of the Employment Impacts and Policy Responses SERBIA, International Labour Organization, in collaboration with European Bank for Reconstruction and Development, 1st September 2020.
- [3] Ćurić, N., Contribution of serbian local self-governments toward environmental protection effectiveness and efficiency, based on the programme budgeting, VII International Conference Industrial Engineering and Environmental Protection 2017 (IIZS 2017), Zrenjanin, Serbia, pp 94-99, 2017.
- [4] Decree on Capital Projects Management (Serbian Official Gazette, no 51 from 19th July 2019.
- [5] Public finance bulletin 6/22, number 190, Belgrade 2020, Republic of Serbia Ministry of Finance.

NO₂ AQI ANALYSIS AS A MEASURE OF AIR POLLUTION REDUCTION IN THREE CITIES IN SERBIA, CAUSED BY THE QUARANTINE DUE TO THE COVID 19 PANDEMIC

Veselin Bežanović¹, Mladenka Novaković¹, Dušan Milovanović¹, Dragan Adamović¹

¹University of Novi Sad, Faculty of Technical Sciences, Novi Sad, Serbia

e-mail: veselinbezanovic@uns.ac.rs

Abstract: The first case of COVID 19 infection in Serbia was confirmed on March 06, 2020. State of emergency was declared imposing shelter in place measures and curfew in the evening hours. Globally, number of countries has experienced air quality improvements during the pandemic caused by the mandatory quarantine. This study aims to analyze the effect of the quarantine on the air quality, during six weeks' period in the cities of Pančevo, Belgrade and Niš, on the territory of the Serbia, from March 16 to April 26, 2020 (42 days), comparing the daily values of Air Quality Index (AQI) for NO₂, between the period during the quarantine with values obtained in the same period in 2019. NO₂ levels showed the significant reductions in all analyzed cities since they were related to the emissions caused by light-duty vehicles. The results demonstrate the high impact of restricted traffic on the nature of air pollution in Serbia.

Key words: COVID 19, AQI, quarantine, NO₂

INTRODUCTION

In the late December 2019, China sent the alert to the World Health Organization (WHO), about various cases of unusual pneumonia which has started in city of Wuhan. Briefly afterwards, during the first week of January 2020, the identification of a new virus, Severe Acute Respiratory Syndrome Coronavirus-2 (SARS-CoV-2) named COVID 19 was announced [1].

At the demand of Chinese government, on January 23, entire country has been placed in the lockdown and quarantine, as a measure to prevent the spread of infection and lessen the burden on health facilities [2].

With more than 118,000 cases of COVID 19 infection in more than 114 countries, on March 12, 2020, WHO announced COVID-19 outbreak as a pandemic [3].

First cases of COVID 19 infection in Europe were reported on February 21, 2020 [4].

In Serbia, the first case of COVID 19 infection was confirmed on March 6, 2020, in the city of Subotica, and until March 15, 47 confirmed cases of COVID 19 infection had been registered. On March 16, a State of Emergency was declared in order to prevent the spread of COVID 19 infection. This decision directly resulted in the lockdown of borders for foreign nationals, the suspension of work of pre-schools, elementary schools and high schools, higher education institutions, fitness centers and public parks. After only three days, a curfew had been imposed from 8pm-5am for all people less than 65 years of age, while older than 65 were completely barred from leaving their shelter at any part of the day. On March 19, International airport Nikola Tesla was closed, except for humanitarian and cargo flights, and on March 20 the first death case caused by COVID 19 was reported.

On March 21, complete quarantine was ordered: all borders for all passengers were closed, road, rail and river traffic were closed, public urban and interurban transport were stopped, cafes and restaurants were closed, and all events were canceled.

The aforementioned measures caused by the COVID 19 pandemic, resulted in absence of all types of traffic, but in the same time, coal-fired combined heat and power plants (CHPs) were continuously operating and noticeable changes in air quality and levels in air pollution due the COVID-19 pandemic quickly became a new topic of different research studies.

Significant changes in air quality were observed in the period before and during the COVID 19 pandemic. Decrease in NO₂ levels over China during quarantine compared to period before quarantine was identified [5].

Reduction of NO₂ levels in Brazil and Kazakhstan were also reported [6, 7]. The main goal of this work is to discuss the impact of COVID-19 pandemic on the air quality in the capital city of Belgrade

and cities Pančevo and Niš in Republic of Serbia, comparing the values of Air Quality Index (AQI) of nitrogen dioxide (NO₂).

MATERIAL AND METHODS

Studied locations

The Republic of Serbia is a landlocked country located at the intersection of Central and Southeastern Europe in the southern Pannonia lowlands and the central Balkans, with about 6.9 million permanent residents according to the data from 2018 by the Statistical Office of the Republic of Serbia (Statistical Office of the Republic of Serbia, 2020). Focus of this study were three cities, shown in Figure 1 and Table 1, with the available values of AQI data for NO₂ for 2019 and 2020.

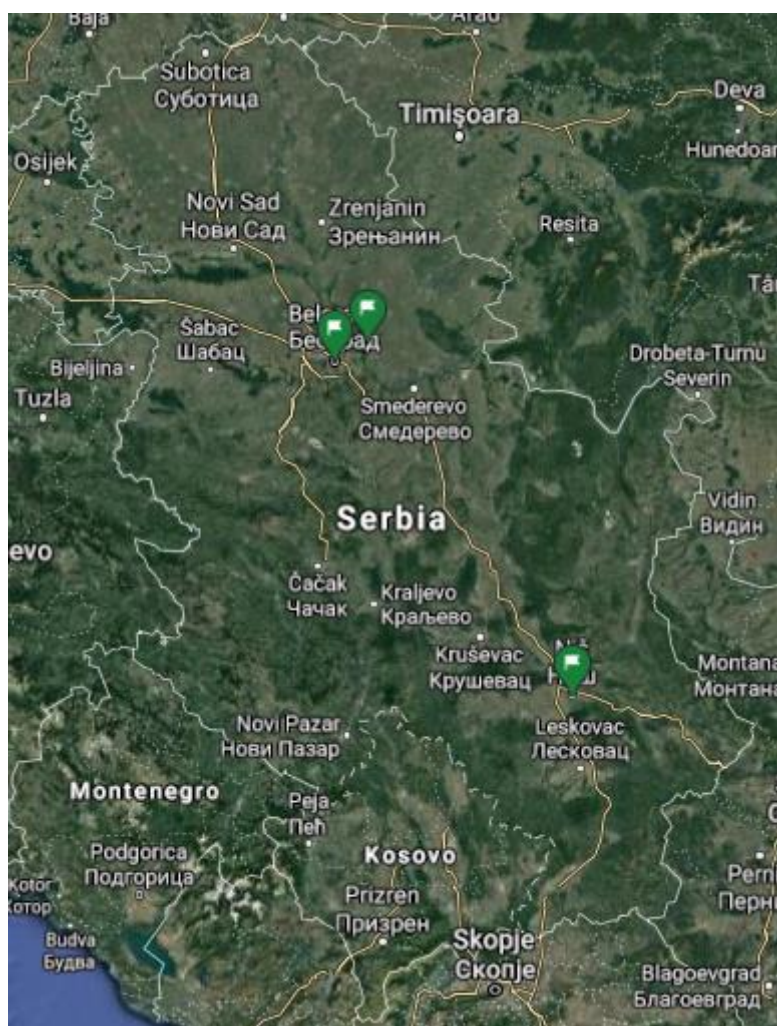

Fig 1. Location on analyzed cities in Serbia

Table 1. Main characteristics of monitoring locations with measured air quality data provided by SEPA Serbian Protection Agency

City	Classification	Zone	Pollutant	Latitude	Longitude	Altitude (m)
Pancevo	industrial	suburban	NO ₂	44° 51' 31" N	20° 38' 56" N	80
Belgrade	background	urban	NO ₂	44° 48' 11" N	20° 24' 0" N	74
Nis	traffic	urban	NO ₂	43° 19' 28" N	21° 54' 11" N	200

Experimental data

One option that can help in assessing the state of air quality before and during the pandemic is to compare the values of Air Quality Index (AQI). AQI is a dimensionless indicator showing synthetically the overall state of air pollution.

The AQI is calculated from the geometric average of considered pollutants by assessing the air quality rating (AQR) of each pollutant [8]. The AQI methodology considers pollutants, such as PM₁₀, PM_{2.5}, CO, NO₂, O₃, SO₂, which cause an acute issues on human health [9]. US Environmental Protection Agency (EPA) developed Air Quality Index (AQI) which focuses on health effects that may occur within a few hours or days after breathing unhealthy air. To make it easier to understand, the AQI is divided into six levels of health concern, shown in Table 2 [10].

Table 2. Levels of Air quality index and health concern

AQI Values	Levels of health concern
0 – 50	Good
51 – 100	Moderate
101 – 150	Unhealthy for Sensitive Groups
151 – 200	Unhealthy
201 – 300	Very Unhealthy
301 – 500	Hazardous

During each day, on thousand locations across the World, monitors record each concentration of the major pollutants. Those values are later converted into a separate AQI value for each pollutant using standard formulas developed by EPA, and the highest of these AQI values is reported as the AQI value for that day [10].

Reported AQI values for Serbia are calculated using Air Quality Data provided by SEPA - Serbian protection Agency. Web site “World’s Air Pollution: Real time air quality index” offers daily real-time AQI conditions for more than thousand cities across the World. In this Study, during the analyzed period for three cities in Serbia, data was obtained using the AQI values database on the above mentioned web site.

Experimental data obtained by the monitoring stations provided by SEPA were initially analyzed to identify spurious data, and values were organized in spreadsheets as daily mean for six weeks period in 2019 and in 2020 during quarantine period.

RESULTS AND DISCUSSION

Experimental results used for calculation of AQI, provided by SEPA, were obtained in the period from March 16 to April 26, for 2019 and 2020 (quarantine period), from monitoring stations of Pancevo, Belgrade and Nis. During the analyzed period, in 2020, a State of emergency caused by COVID 19 pandemic was in force, borders were closed, public and intercity transport was canceled, and a ban on movement was imposed (night time during weekdays, and the entire weekend). In Europe, biodiesel is most used in transportation, agriculture, forestry and construction and due to their bio-degradability characteristic and less emission of harmful gases in a comparison to the classic fuel.

Impact of the COVID 19 quarantine on the values of AQI for NO₂

Serbia implemented strict traffic restrictions during quarantine to control the expansion of COVID 19. During six weeks' period, these actions generated changes in air pollution, shown in Fig. 2.

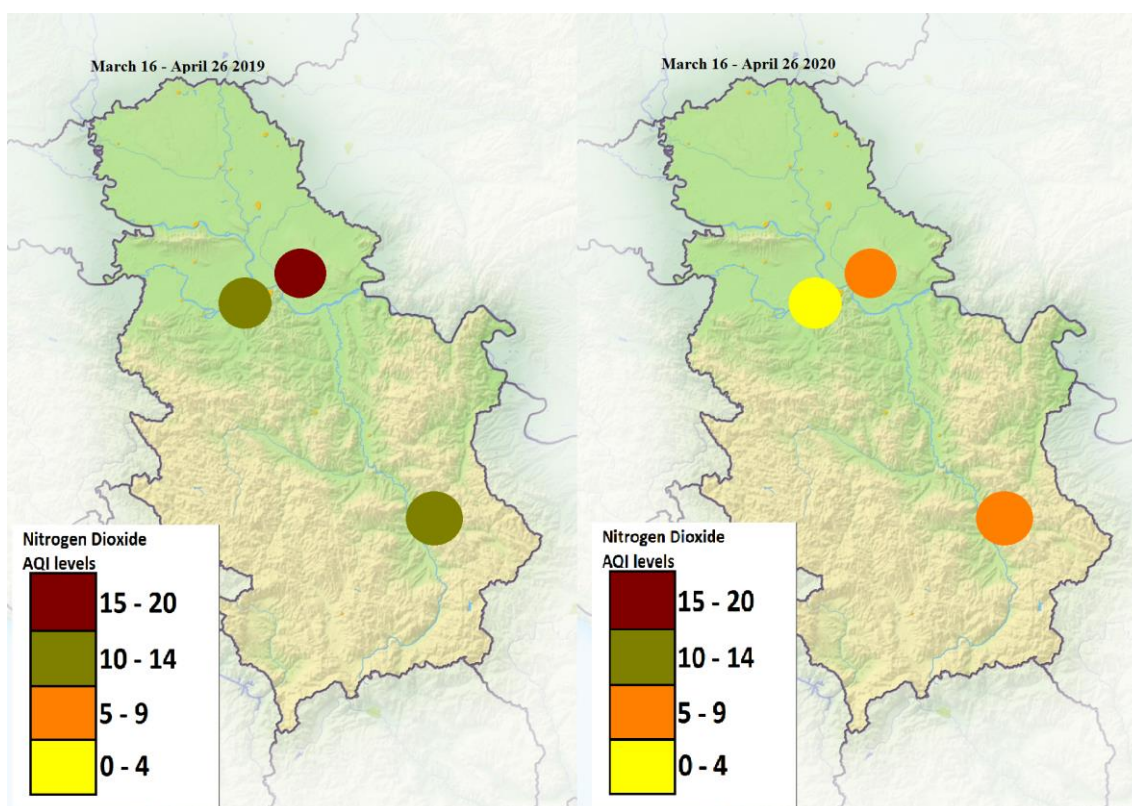

Fig. 2 Average values of AQI for NO₂ in Serbia, for six weeks period in 2019 and 2020

The results of spatial distribution shown in Fig. 2 represent similarities in the spatial profiles in three cities in 2019 and 2020, but variations in range values are not different. Average AQI values for NO₂ do not exceed thresholds for good health concern in none of the observed cities.

The values of AQI for NO₂ (min, max and averaged for all stations) during the quarantine period indicate a reduction of the NO₂ concentration by 58% to 67% in 2020 (during quarantine) compared to the same period in 2019, as shown in Table 3.

Table 3. Average values of AQI for NO₂ in the period between March 16 and April 26 in 2019 and 2020

City	Year								Percent change
	2019				2020				
	Average	Min	Max	SD	Average	Min	Max	SD	
Pancevo	19	4	62	14	8	2	26	5	-58%
Belgrade	12	4	22	6	4	1	19	4	-67%
Nis	12	5	17	3	5	1	11	3	-58%

CONCLUSION

COVID 19 pandemic resulted in absence of all types of traffic which is directly caused by State of Emergency that is declared on March 16 in Serbia. This study compared the same six weeks' period in 2019 and 2020, to show the impact of the quarantine, caused by COVID 19 pandemic, on the air quality in three cities in Serbia by comparing the values of NO₂.

Strict traffic restrictions in combination with restriction of movement did have huge impact on NO₂ levels which showed the most significant reductions in all cities, between 58% – 67%.

The state of emergency and quarantine period caused by COVID 19 pandemic was a unique opportunity for analysis on the scope of impact of urban and suburban transport on air quality in Serbia. The results showed that traffic free conditions have huge impact on reduction of NO₂ pollutant. However, reduction of pollution levels caused by PM_{2.5} and PM₁₀ should be also analyzed, since different emission sources, primarily meteorological conditions, dominate in the pollution profile over Serbia.

REFERENCES

- [1] WHOa (World Health Organization), 2020. http://www.euro.who.int/en/health-topics/health-emergencies/novel-coronavirus-2019-ncov_old, accessed in May 2020.
- [2] Wilder-Smith, A., & Freedman, D. O. (2020). Isolation, quarantine, social distancing and community containment: Pivotal role for old-style public health measures in the novel coronavirus (2019-nCoV) outbreak. *Journal of Travel Medicine*, 27(2), 1–4.
- [3] WHOb (World Health Organization), 2020. <https://www.who.int/dg/speeches/detail/who-director-general-s-opening-remarks-at-the-media-briefing-on-covid-19---11-march-2020>, assessed in May 2020.
- [4] ECDC (European Centre for Disease Prevention and Control) (2019). <https://www.ecdc.europa.eu/en/geographical-distribution-2019-ncov-cases>, assessed in May 2020.
- [5] Earth Observatory NASA (2020). <https://earthobservatory.nasa.gov/images/146362/airborne-nitrogen-dioxide>, assessed in May 2020.
- [6] Dantas, G., Siciliano, B., França, B. B., da Silva, C. M., & Arbilla, G. (2020). The impact of COVID-19 partial lockdown on the air quality of the city of Rio de Janeiro, Brazil. *Science of the Total Environment*. Elsevier B.V
- [7] Kerimray, A., Baimatova, N., Ibragimova, O. P., Bukenov, B., Kenessov, B., Plotitsyn, P., & Karaca, F. (2020). Assessing air quality changes in large cities during COVID-19 lockdowns: The impacts of traffic-free urban conditions in Almaty, Kazakhstan. *Science of the Total Environment*, 730, 139179.
- [8] Chaudhuri, S., & Chowdhury, A. R. (2018). Air quality index assessment prelude to mitigate environmental hazards. *Natural Hazards*, 91(1), 1–17.
- [9] Lanzafame, R., Monforte, P., Patanè, G., & Strano, S. (2015). Trend analysis of Air Quality Index in Catania from 2010 to 2014. *Energy Procedia*, 82, 708–715.
- [10] U.S. EPA (Environmental Protection Agency). (2014). Air Quality Index. A Guide to Air Quality and YourHealth. https://doi.org/10.1007/978-94-007-0753-5_100115

IMPACTS OF ORGANIC WASTE MATERIALS ON SOIL CHARACTERIZATION

Hosam Bayoumi Hamuda¹, Katalin Hrustinszki¹, Ágnes Róczy¹,
Mungunzaya Ganbat¹

Óbuda University, Rejtő Sándor Faculty of Light Industry & Environmental Engineering
Institute of Environmental Engineering & Natural Sciences, Budapest-Hungary

E-mail: bayoumi.hosam@rkk.uni-obuda.hu

WhatsApp/viber/messenger: +36303900813

Abstract: Soil organic matter (SOM) is accumulated; decaying debris mainly of plant origin. The organic waste materials and utilization of by-products and end products generated during wastewater treatment has always caused many problems, as the amount of sludge is constantly increasing. The aim of present research work was to measure the effect of organic waste (compost or sewage sludge) on the soil properties and its remedial effect. The soil improvement effect of compost and sewage sludge was investigated on the basis of total organic carbon (TOC), total nitrogen content (TNC), some enzymatic activities and soil respiration at different application rates: 0, 10%, 15%, 20% and 30%. Typically, after 15% of the treatments, a significant change was observed, the rate of soil respiration (CO₂ emission) and the enzymatic activities were increased as a result of the treatments. Evaluating the results, it can be stated that organic waste has an improving effect on the soil in all cases; therefore it can be of great help to soil agriculture and agricultural productivity. The organic wastes have a number of advantages over fertilizers, such as the absence of parasites, infectious agents and heavy metals that are harmful to humans and animals after treatment with sewage sludge. Thus, the use of sewage sludge as compost not only provides a solution to reduce the amount of sludge deposited, but also provides an excellent opportunity to improve soil fertility.

Keywords: Organic waste materials, CO₂ emission, TOC, TNC, Enzymatic activities

INTRODUCTION

Agricultural application of organic solid waste as nutrient source for plants growth and as soil conditioner is the most cost-effective management because of its advantages over traditional means such as land-filling or incineration. Human activities accelerated the changes in the dynamic of soil characteristics. Since the beginning of the 20th century, application of mineral fertilizers has expanded agricultural production and increased yields to feed a rapidly growing world population. But this method has some negative effect on the soil properties. Excessive use of mineral fertilizer has been proven to be detrimental for soil microbial biomass, soil habitat functioning, plant species diversity, plant and even human health [1]. To eliminate these negative effects and to make agriculture more sustainable, the application of organic amendments obtained via cascading, upgrading and recycling of bio-based products has found raising interest [2]. Its application can influence various physical and chemical soil properties such as nutrient availability, soil aeration, water holding capacity and moisture [3]. Moreover, biological properties can be affected as shown for the soil microbial community structure and changes in its quantity, diversity and activity [4]. Organic amendments have been reported to induce various positive but also negative effects on soil health and plant performance [2].

The biological functions of SOM are primarily 1) to provide a reservoir of metabolic energy that drives biological processes, 2) to act as a supply of macro-and micro-nutrients and 3) to ensure that both energy and nutrients are stored and released in a sustainable manner. Importantly, biological processes in turn influence both soil chemical and structural properties as they greatly affect soil structure and soil redox reactions. It is important to note that any changes made to the natural status of the soil systems will result in different conditions under which SO carbon (SOC) enters and exits the system. In addition to OC, elements, the most important of which are nitrogen (N) and phosphorus (P), are needed for microorganisms to function properly. Much smaller amounts of potassium (K), calcium (Ca), magnesium (Mg) irons are required, but the greater or lesser presence of almost all elements is a prerequisite for well-functioning metabolism.

In particular, the suitability of soil for sustaining plant growth and biological activity is a function of physical (porosity, water holding capacity, structure and tilth, etc.) and chemical properties (nutrient supply capability, pH, salt content, etc.), many of which are a function of SOM content [5]. Similarly, Elliott [9] indicated that SOM was a key indicator of soil health but further suggested that particulate OM could be used as an indirect measure of soil health because of its short turnover time. Reeves [10] noted that SOC is the most often reported attribute from long-term agricultural studies and is chosen as the most important indicator of soil quality and agronomic sustainability because of its impact on other physical, chemical and biological indicators of soil quality. The C / N ratio of microbial cells is approximately 5:1. Thus, a C/N ratio of 25:1 is the most appropriate starting point. This value is more of a theoretical value, in the case of persistent organic components such as lignin, it is more appropriate to maintain a C/N ratio of 30-35:1. During composting, the C/N ratio decreases, the C/N ratio of composts (10-20:1) is closer to a similar index of soil organic matter than that of the starting materials.

The objective of this research work is to prove that the use of the generated sewage sludge and compost can be of great help in soil agriculture and agricultural productivity. The soil improvement effects were studied by the application of waste organics on total soil organic C, total N content, soil enzymatic activities and soil respiration at different applied doses (0, 10, 15, 20 and 30).

MATERIALS AND METHODS

Soil for the greenhouse experiment was collected at the Central Research Institute of Agricultural and Technical Sciences of the University of Debrecen (Nyíregyháza, Hungary) from the topsoil (0–25cm). The soil samples were then air-dried and sieved (<2 mm). It was classified as a Brown forest soil. Table 1, shows some physico-chemical characteristics of the soil used and municipal sewage sludge sample from the municipal wastewater treatment plant in Nyíregyháza, as well as some physico-chemical characteristics of the compost sample used in the study were given in Table 2. The experiment was laid out in complete randomized block design having three replicates.

Table 1. Physico-chemical characteristics of the soil and organic waste used in the study

Parameters	Nyíregyháza soil sample	Nyíregyháza wastewater sludge
pH _(KCl)	5.78	6.71
Dry matter content, %	nd	53
Organic material, %	nd	21.7
Humus content, %	2.54	nd
Total-N, mg/kg-1	nd	7470
NO ₃ -N, mg·kg ⁻¹	23	nd
NH ₄ -N, mg·kg ⁻¹	5.6	nd
Mg, mg·kg ⁻¹	214	2507
Na, mg·kg ⁻¹	64	994
P ₂ O ₅ , mg·kg ⁻¹	318	28720
K ₂ O, mg·kg ⁻¹	412	3171
Zn, mg·kg ⁻¹	1.7	537
Cu, mg·kg ⁻¹	1.4	110.4
Mn, mg·kg ⁻¹	55	421
Fe, mg·kg ⁻¹	945	11308
Cd, mg·kg ⁻¹	1.7	2.3
Pb, mg·kg ⁻¹	1.3	66.9

nd: no data available

Table 2. Compost test results (Source: ATEVSZOLG. [32])

Parameters	Measured values	Government Decree 50/2001
P g·kg ⁻¹ dry matter	19.3	> 3
K g·kg ⁻¹ dry matter	15.7	> 5
Na g·kg ⁻¹ dry matter	3.6	-
Ca g/kg dry matter	39.2	> 100
Mg g/kg dry matter	8	> 5
Fe mg·kg ⁻¹ dry matter	15520	nd
Mn mg/kg dry matter	363	nd
Cu mg·kg ⁻¹ dry matter	86.1	750
Zn mg·kg ⁻¹ dry matter	476	2000
B mg·kg ⁻¹ dry matter	28	nd
Mo mg·kg ⁻¹ dry matter	5.9	10
S mg·kg ⁻¹ dry matter	8702	nd
Al mg·kg ⁻¹ dry matter	12110	nd
As mg·kg ⁻¹ dry matter	< 5	25
Hg mg·kg ⁻¹ dry matter	< 2.00	5
Cd mg·kg ⁻¹ dry matter	0.7	5
Co mg·kg ⁻¹ dry matter	5	50
Cr mg·kg ⁻¹ dry matter	29	350
Cr(VI) mg·kg ⁻¹ dry matter	< 0.1	1
Ni mg/kg dry matter	17.2	100
Pb mg/kg dry matter	58.1	400
Se mg/kg dry matter	< 5	50
pH _(KCl)	6.85	Dry matter content (%) 45.4
Organic matter (OM) (%)	20.3	nd: no data available.

Organic waste and soil treatment: The air-dry soil was thoroughly mixed with the sewage sludge or compost so that the finished mixture contained the following percentages by weight of organic waste: 0% (control soil), 10, 15, 20, and 30%.

Sampling: Sampling was performed in the initial phase (week 1; initial) and finally during harvesting (week 4; final). Each sample had 3 technical replicates.

Soil samples were (1 g) taken in week 1 and 4 for extracellular enzyme activity measurements were collected from the upper 10 cm in the centre of each pot. Soil material for enzyme activity was stored at 4°C.

SOIL CHEMICAL AND BIOCHEMICAL ANALYSIS

Determination of total organic carbon (TOC) in soil: Soil organic carbon (OC) was determined by reduction of potassium dichromate (K₂Cr₂O₇) by OC and subsequent determination of the unreduced dichromate by oxidation-reduction titration with 0.5 M ferrous ammonium sulfate according to Walkley & Black [11] method. The amount of oxidized OC is multiplied by 1.334 to give the final amount of soil organic matter.

Determination of total soil nitrogen content according to Kjeldahl (TNT): Total soil N content was determined with a Kjeldahl instrument as described by Keeney and Nelson [12].

Determination of enzymatic activities

Fluorescein diacetate (3',6'-diacetyl-fluorescein, FDA) hydrolyzing activity of the soil sub-samples were determined by measuring the released fluorescein at 490 nm according to ALEF [8]. The activity was expressed as mg hydrolyzed fluorescein/kg soil dry weight/h. Dehydrogenase activity was determined by the method of García et al. [13] and expressed as mg INTF/kg dry soil. Urease activity (μmol NH₄⁺-N g⁻¹ dry soil h⁻¹) was determined in 0.1 M phosphate buffer at pH 7; 1 M urea and 0.03 M N α-benzoylargininamide (BAA) was used as substrate. The activity was determined by the NH₄⁺ released [14]. Acid phosphatase and β-glucosidase activities were determined (μg p-nitrophenol/g

soil/h) by spectrophotometry at 398 nm [15]. Similarly, Aryl-sulphatase activity was measured colorimetrically at 420 nm (μg p-nitrophenol/g soil/h) according to Tabatabai and Bermned, [16].

Evaluation of soil respiration

To determine the soil basal respiration rates, 50 g of soil samples were placed in hermetically sealed glass bottle, moistened at 45% and incubated in the dark at 28°C for 7 days. The amount of OC released as CO_2 and absorbed in vials containing 10 ml of 0.5 M NaOH placed inside bottle. The CO_2 emitted was measured as the Na_2CO_3 formed by titration with 0.1 M HCl.

Statistical analysis: The experiment was set up in a randomized block design, in triplicate, with three replicates. Correlation based on single classification was used to calculate statistically significant differences between treatments. Significant deviation was calculated at $P < 0.05$.

RESULTS AND DISCUSSION

Furthermore, biological and biochemical parameters, e.g., enzymatic activities, are considered early and sensitive biomarkers of soil quality. Monitoring soil quality by means of bioindicators can be of help for the management and sustainability of soils that received MSS application [17]. Since soil quality cannot be measured directly, different fast responding chemical and biological indicators had to be assessed within this study. Soil OM supports more physical, chemical and biological processes sustaining vital ecosystem functions in addition to C sequestration and as a source of nutrients and energy for living organisms,

Total organic carbon content of soil: The total organic carbon (OC) content (Fig. 1.) started to increase even after the 10% treatment. Compared to the initial 0.67 mg / kg, compost treatment resulted in a soil TOC content of 2.15 mg / kg, while treatment with sewage sludge resulted in a value of 2.42 mg / kg.

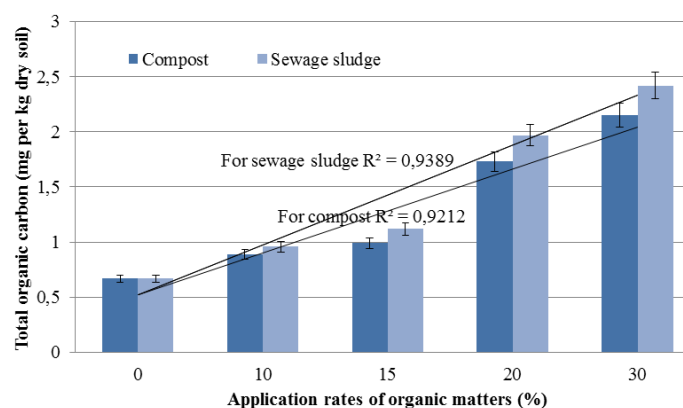

Fig. 1. Changes in the total organic carbon content of brown forest soil after organic waste treatments

Total nitrogen content of soil: The initial total nitrogen content of covariate brown forest soil (Fig. 2.) was 34.6 mg / kg. The 10% treatment did not improve the value; however, the 15% treatment already showed a change, in the case of compost the measured result was 46.7 mg / kg and 49.2 mg / kg. The 30% treatment resulted in 77.5 mg / kg after compost treatment, while the sewage sludge treatment resulted in 83.8 mg / kg

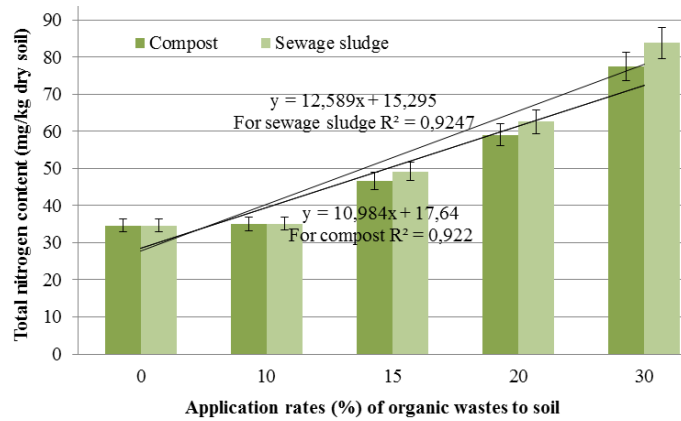

Fig. 2. Changes in total nitrogen content of brown forest soil after organic waste treatment

Effect of organic wastes on soil biochemical activity: The biochemical activity of brown forest soil was investigated based on the following parameters: fluorescein diacetate (FDA) - (Figure 3), dehydrogenase (Figure 4), urease (Figure 5), acid phosphatase (Fig. 6), β -glucosidase (Fig. 7), aryl sulfatase (Fig. 8) activity.

Based on the obtained results, it can be stated that in all cases there was an increase in activity. Even with the 10% treatment, increasing activity can be seen. The biochemical activity of the soil under the treatment with sewage sludge yielded better results than the treatment with compost.

Soil dehydrogenase activity refers to the total oxidative activity of the soil microbiota and is therefore a good indicator of the degree of microbiological activity. The addition of sewage sludge and compost increased the dehydrogenase activity as well as the catalase activity in all treatments.

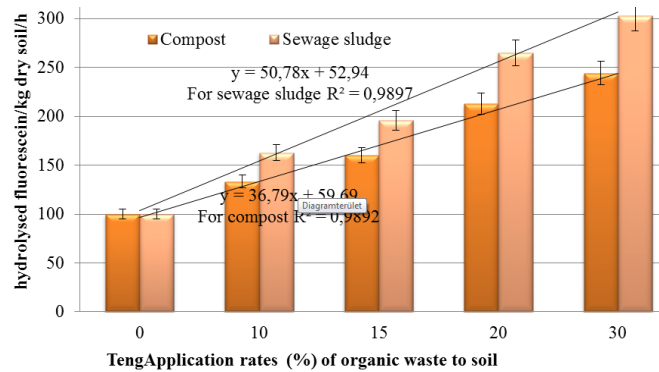

Fig. 3. Changes in FDA activity in brown forest soil after organic waste treatments

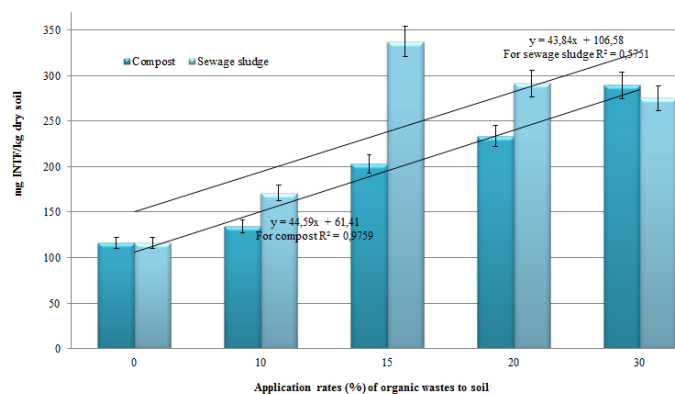

Fig. 4. Changes in dehydrogenase activity in brown forest soil after organic waste treatment

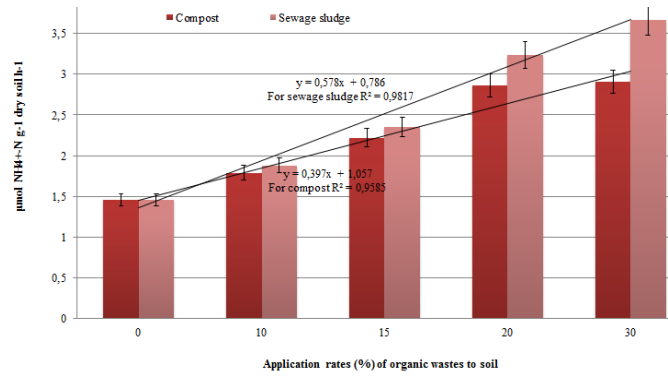

Fig. 5. Changes in urease activity in brown forest soil after organic waste treatments

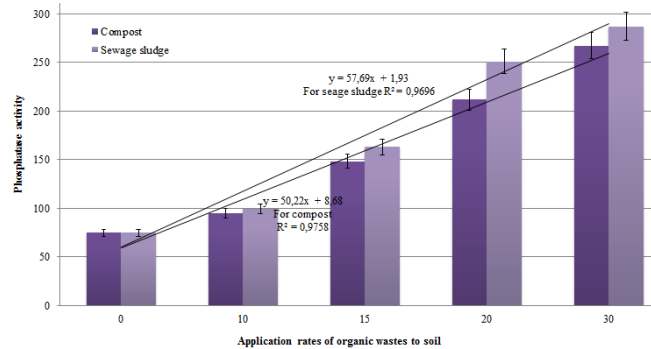

Fig. 6. Changes in acid phosphatase activity in brown forest soil after organic waste treatments

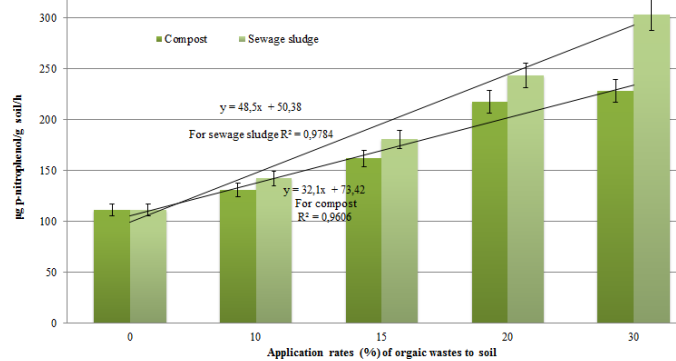

Fig. 7. Changes in β -glucosidase activity in brown forest soil after organic waste treatments

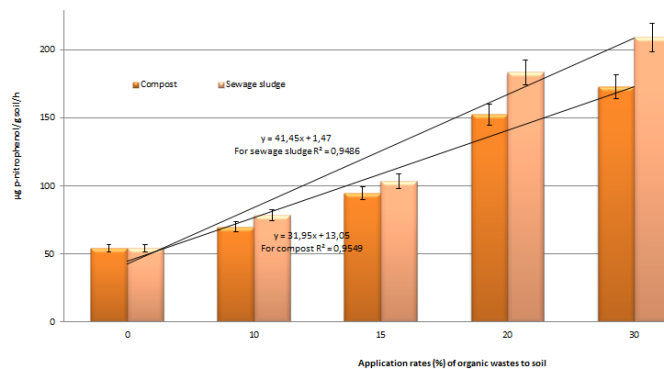

Fig. 8. Changes in aryl-sulfatase activity in brown forest soil after organic waste treatments

Effects of organic waste on soil respiration: The extent of soil respiration can provide valuable information on the increased metabolic activity of soil microorganisms. As a result of the different treatments, CO₂ emissions (Fig. 9) started to increase continuously. Both compost and sewage sludge

significantly increased soil respiration. The correlation factor almost reaches an integer value, so this result is excellent.

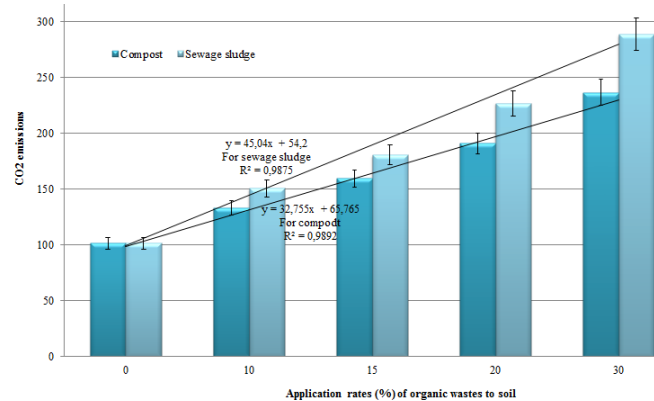

Fig. 9. Changes in respiration (CO₂ emissions) of brown forest soil after organic waste treatments

Since then, the decomposition and composting of sewage sludge has developed in parallel in the last century. Once again, only half a hundred years later, the current rate of loading of living waters with plant nutrients and the uncontrolled removal of sludge into soils with similar rates became unsustainable. Most soil functions are dependent on soil organic matter decomposition and require labile compounds. The scientific basis for the composting of sewage sludge is accordingly in the XX. they were developed from the middle of the 19th century. By the end of the century, this knowledge had deepened sufficiently. However, the accelerated development of technical knowledge (aeration machines, equipment, process control, solar energy utilization, solar drying in colder climates) is expected to bring about a leap in the technical practice of composting sewage sludge in the near future. The foundations for this are the previous knowledge of biotechnology knowledge and process engineering "Process Engineering"

The results of our experiments support those reported in the above works, according to which the density of microbial populations is related to the amount of sewage sludge mixed with the soil. Our results are in line with those reported in the above-mentioned work, according to which increasing the proportion of sewage sludge mixed with soil increases fertility and the density of microbial populations as well as soil enzyme activity. With the disposal of sewage sludge, organic and fertilizer can be partially replaced, as well as treatment that improves the physico-chemical properties of the soil. However, for food safety reasons, continuous health monitoring methods are recommended..

Our studies have shown that: 1. the microbial activity of the soil depends on the C and N content of the soil, the type of soil and the amount of sewage sludge mixed with them; 2. soil respiration and soil enzyme activity also increase with the addition of sewage sludge; 3. as a result of the periodic treatment of the soil with sewage sludge, a balanced state can be achieved in the circulation of nutrients that are also vital for plants.

In our opinion, the most appropriate place for this type of use of sewage sludge is agriculture, where sewage sludge would be applied taking into account the nutrient requirements of the plants and the capacity of the soil. Based on the results of a model experiment, we found that both types of sewage sludge do not inhibit germination, and the positive effect of raw sewage sludge is more pronounced. Germination inhibition is more pronounced with increasing doses. The growth of plants, the change of height and the air-dry weight also decreased due to the increasing doses of sewage sludge doses, the positive effect of sewage sludge in Hódmezővásárhely is more pronounced. We consider it important to continue the research, to study the process with a longer-term observation of other soil conditions.

Our studies have shown that: 1. the microbial activity of the soil depends on the C and N content of the soil, the type of soil and the amount of sewage sludge mixed with them; 2. soil respiration and soil enzyme activity also increase with the addition of sewage sludge; 3. as a result of the periodic treatment of the soil with sewage sludge, a balanced state can be achieved in the circulation of nutrients that are also vital for plants.

Soil OM supports multiple soil ecosystem functions, underpinned by processes such as C sequestration, N mineralization, aggregation, promotion of plant health and compound retention [6]. Applying organic amendments improved and maintained soil health, contributing to more sustainable crop production. Nevertheless, long-term field studies are recommended to verify the findings of this short-term experiment [7].

The basic principle of our technologies developed for composting municipal sewage sludge is agricultural utilization, i.e., product development and product trade. The ad hoc placement permit, based on soil tests, which was common in the previous period, is only assessed as a temporary condition.

The main aspects of technological developments are therefore the presentation as a product:

- technology with low investment needs - influencing the biological process;
- product composition adapted to agricultural and physiological needs;
- ensuring biological and economic competitiveness with fertilizers;
- production of product types adapted to the regional agricultural structure.

CONCLUSION

The objective of this research work is to prove that the use of the generated sewage sludge and compost can be of great help in soil agriculture and agricultural productivity. The soil improvement effects were studied by the application of waste organics on total soil organic C, total N content, soil enzymatic activities and soil respiration at different applied doses (0, 10, 15, 20 and 30).

The purpose of compost and sewage sludge as an organic matter (OM) content is to be used as organic fertilizer in agricultural production after the biological stabilization of their organic matter (OM) content. In conclusion, working with waste OM could be confirmed showing maintained soil quality and improved soil by increasing the TOC and TNC as well as the enzymatic activities at the all applied rates. This needs more investigations with different soil types and different organic waste materials with low and high heavy metals content. The comprehensive approach of the present greenhouse study revealed strong changes of soil biological properties which dependent on organic amendment application. Interestingly, soil performance was improved by all treatments but differences between organic amendment applications were observed. The majority of soil parameters remained stable throughout the study and across different applications, indicating maintained soil quality. Microbiological investigations are needed to check the relation between the enzymatic and microbial activities. Long-term experiments have to scrutinize these findings under field conditions to find optimal organic fertilizer for different agroecosystems.

REFERENCES

- [1] Geisseler, D., Scow, K, Long-term effects of mineral fertilizers on soil microorganisms – a review. *Soil Biol Biochem*, 75:54–63, 2014.
- [2] Schröder P, Beckers B, Daniels S, et al., Intensify production, transform biomass to energy and novel goods and protect soils in Europe-a vision how to mobilize marginal lands. *Sci Total Environ* 616-617: 1101–1123., 2018.
- [3] Haider G, Steffens D, Moser G, Müller C, Kammann C (2016) Biochar reduced nitrate leaching and improved soil moisture content without yield improvements in a four-year field study. *Agric Ecosyst Environ* 237:80–94
- [4] Schmid CAO, Schröder P, Armbruster M, Schloter M (2017) Organic amendments in a long-term field trial—consequences for the bulk soil bacterial community as revealed by network analysis. *Microb Ecol* 76(1):226–239
- [5] Doran J.W., Safley M. (1997): Defining and assessing soil health and sustainable productivity. In: *Biological Indicators of Soil Health* (Eds.: Pankhurst C.E., Doube B.M., Gupta V.V.S.R.) 1–28. CAB International, Wallingford, Oxon, UK.
- [6] Hoffland, E., Kuyper, W. Thomas, C. N. J. Rob, Creamer. E.R..Eco-functionality of organic matter in soils. *Plant and Soil*, (2020) 455:1–22, 2020. <https://doi.org/10.1007/s11104-020-04651-9>.

- [7] Obermeier, M.M., Minarsch, L E-M, Raj,D.C.A., et al., Changes of soil-rhizosphere microbiota after organic amendment application in a *Hordeumvulgare* L. short-term greenhouse experiment. *Plant Soil*, 455:489–506, 2020. <https://doi.org/10.1007/s11104-020-04637-7>
- [8] Alef K., Estimation of soil respiration. In: *Methods in applied microbiology and biochemistry* (Eds.: Alef K., Nannipieri P.) 215–216, 1995. Academic Press. London.
- [9] Elliott E.T., Rationale for developing bioindicators of soil health. In: *Biological Indicators of Soil Health*. (Eds.: Pankhurst C.E., Doube B.M., Gupta V.V.S.R.) pp. 49–78. CAB International, Wallingford, Oxon, UK. 1997.
- [10] Reeves D.W., The role of soil organic matter in maintaining soil quality in continuous cropping systems. *Soil Tillage Res.*, 43: 131–167. 1997
- [11] Walkley, A. & Black, I.A., An examination of the Degtjareff method for determining soil organic matter, and a proposed modification of the chromic acid titration method. *Soil Sci.*, 37, 29-38. 1934
- [12] Keeney, D. R., Nelson, D. W.: Nitrogen-inorganic forms. In: Page, A. L., Miller, R. H., Keeney, D. R. (Eds.) *Methods of soil analysis*. American Society of Agronomy, Madison, 1982, 643–698.
- [13] García, C., Hernandez, T. & Cost, F., Potential use of dehydrogenase activity as an index of microbial activity in degraded soils. *Commun. Soil Sci. Plant Anal.*, 28, 123-134. 1997
- [14] Nannipieri, P., Ceccanti, B., Cervelli, S. & Matarese, E., Extraction of phosphatase, urease, protease, organic carbon and nitrogen from soil. *Soil Sci. Soc. Am. J.*, 44, 1011-1016. 1980.
- [15] Tabatabai, M.A. & Bermned, J.M., Factors affecting soil aryl-sulphate activity. *Soil Sci. Soc. Am. Proc.*, 34, 427-429. 1969
- [16] Tabatabai, M.A. & Bermned, J.M., Use of P-nitrophenol phosphate in assay of soil phosphatase activity. *Soil Biol. Biochem.*, 1, 301-307. 1970
- [17] Bayoumi Hamuda,, H.E.A.F., Ligetvári, F. Impacts of municipal sewage sludge on dynamics of organic matter and biological activities in clay loam brown forest soil. *J. Residual Science & Technology*, 8, 143-149. 2011.

INFLUENCE OF CLIMATE CHANGE AND URBAN DEVELOPMENT ON GNSS MEASUREMENTS

Alina Bălă¹, Luisa Dungan², Clara-Beatrice Vilceanu¹, Sorin Herban¹

¹University Politehnica Timișoara, Faculty of Civil Engineering, Department of Overland
Communication Ways and Cadastral Survey, Timișoara, România,

²University Politehnica Timișoara, Faculty of Mechanical Engineering, Department of
Mechanical Machines, Equipment and Transportation, Timișoara, România

e-mail: alina.bala@upt.ro, luisa.dungan@upt.ro, beatrice.vilceanu@upt.ro,
sorin.herban@upt.ro

Abstract: In the last decade, major advances of observation techniques have been achieved in geodetic engineering by the continuous development of GNSS (Global Navigation Satellite System) technology. The advantages offered by this GNSS (Global Navigation Satellite System) technology, also in Romania, have led to the necessity of implementing modern services for position determining that give users more information in addition to that received directly from the satellites GNSS, thus obtaining higher accuracy in real time positioning. However, due to climate change and emergence of dense urban spaces, the poor performance of GNSS positioning has remained a major challenge both for navigation and precise determination of points. Scientific research within this paper describes the various GNSS observations in different sessions in order to improve the accuracy of determining the position of a point, using the urban area of Timisoara and influences characteristic to environmental dispersion. In Satellite Geodesy refraction plays an important role because it generates variations in the speed of propagation of GNSS signals thus directly influencing its time propagation measurement. The positioning problem in crowded spaces or areas with obstructed satellite signals represents a geodetic problem concerning a wide range of scientific areas for various GNSS applications. This affirmation can be confirmed by choosing different GNSS methods and testing elevation angle cut off in order to generate future necessary data for statistical analysis.

Key words: climate, urban space, GNSS, elevation, positioning, environment

INTRODUCTION

GNSS positioning is affected by obstructions in typical environments like in urban areas, in forests, or in the vicinity of bridges and overpasses. These obstructions attenuate the GNSS signals below the tracking threshold of conventional receivers. Reliable navigation using GNSS alone may not be possible in such environments. Recently, high sensitivity (HS) receivers with a much lower tracking threshold have become available. They can track extremely weak signals and thus provide more observations, increased solution availability, and better geometry than a conventional receiver. However, signal attenuation is usually associated with signal delay e.g. caused by multipath or diffraction. Weak signals will usually yield less accurate measurements. The positioning algorithm needs to account properly for the different quality of the observations; otherwise any potential gain due to the increased observation availability is annihilated by the effect of uncorrected delays [1].

The varying atmosphere exerts two disturbing forces on the gravity signal: first the so-called direct effect or Newtonian attraction, where the object in questions is attracted by the atmospheric mass itself; and second the indirect effect or atmospheric loading where the overlying atmospheric mass has a deforming effect on the Earth's surface, also changing the measured gravity signal. In satellite gravity missions, these short-period signals cause aliasing effects in the gravity field determination and their elimination is indispensable [2].

MATERIAL AND METHODS

GNSS positioning and influences characteristic to environmental dispersion

Climate change and urban development will exacerbate current urban heat island effects. While most studies acknowledge the importance of projected temperature increases for raising urban temperatures, little attention is paid to the impacts of future changes in urbanization patterns. Yet, steering urban

development may be an effective strategy to further limit increases in the intensity and spreading of the urban heat island effect. Climate change will, on average, have a limited impact on these changes. Large impacts can, however, be expected from the combination of urban development and potentially more frequent occurrences of extreme climatic events such as heat waves. Spatial planning strategies that reduce the lateral spread of urban development will thus greatly help to limit a further increase in urban heat island values [3].

However, due to climate change and emergence of dense urban spaces, the poor performance of GNSS positioning has remained a major challenge both for navigation and precise determination of points. Scientific research within this paper describes the various GNSS observations in different sessions in order to improve the accuracy of determining the position of a point, using the urban area of Timisoara and influences characteristic to environmental dispersion.

Timisoara municipality is located in the western part of Romania – latitude = 45.748, longitude = 21.2086, representing a developed urban city, as shown in Fig. 1.

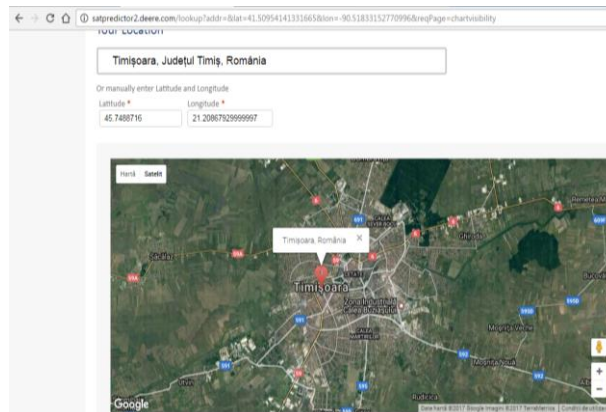

Fig. 1. Timisoara city localization on the satellite map [4]

In order to realize a performant preliminary assessment of GNSS technology used for precise points determination using Real Time Kinematic positioning in crowded environments of Timisoara city, we performed analyses of atmospheric influences, during March-April 2017, using open source platforms (Fig.2).

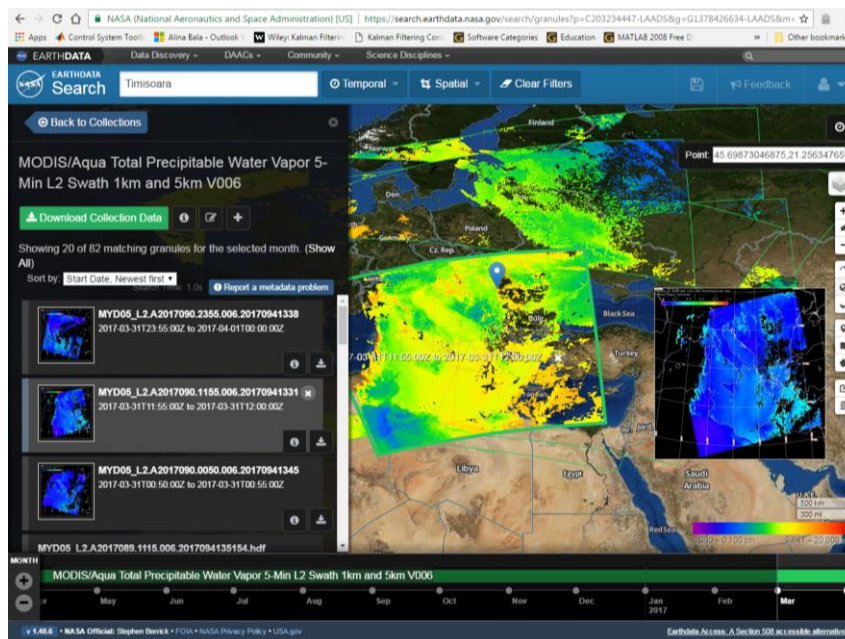

Fig. 2. Atmospheric influences during March-April 2017 [5]

GNSS data collection period was chosen in April according to online planning missions realized using a minimum angle of 100 elevation (Fig.3 and Fig.4). This elevation angle is used to reduce measurements from satellites having small elevation angles.

Satellite Predictor

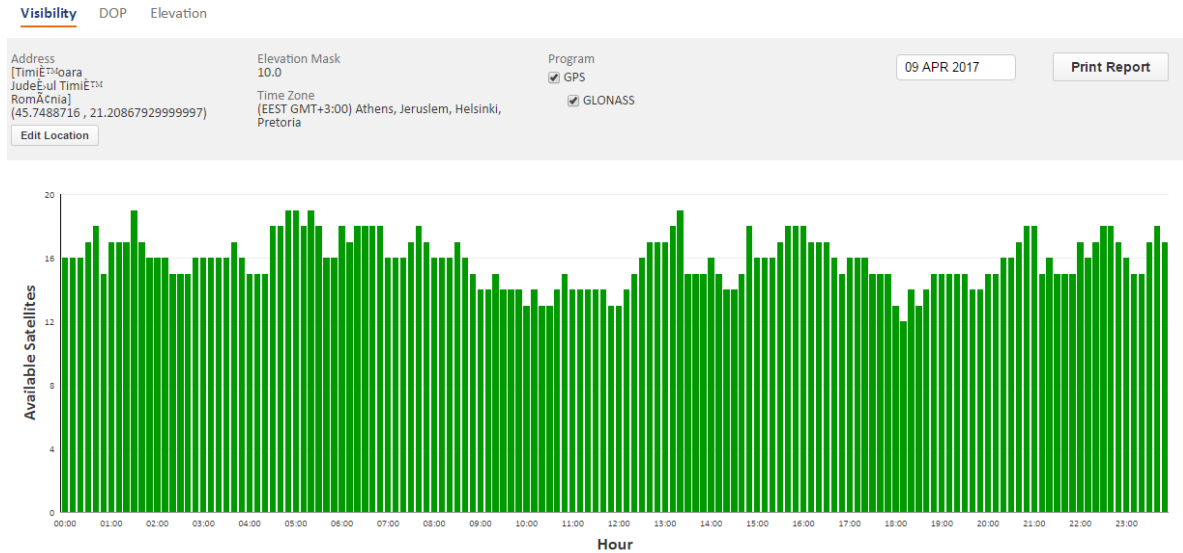

Fig. 3. Number of visible satellites [4]

Satellite Predictor

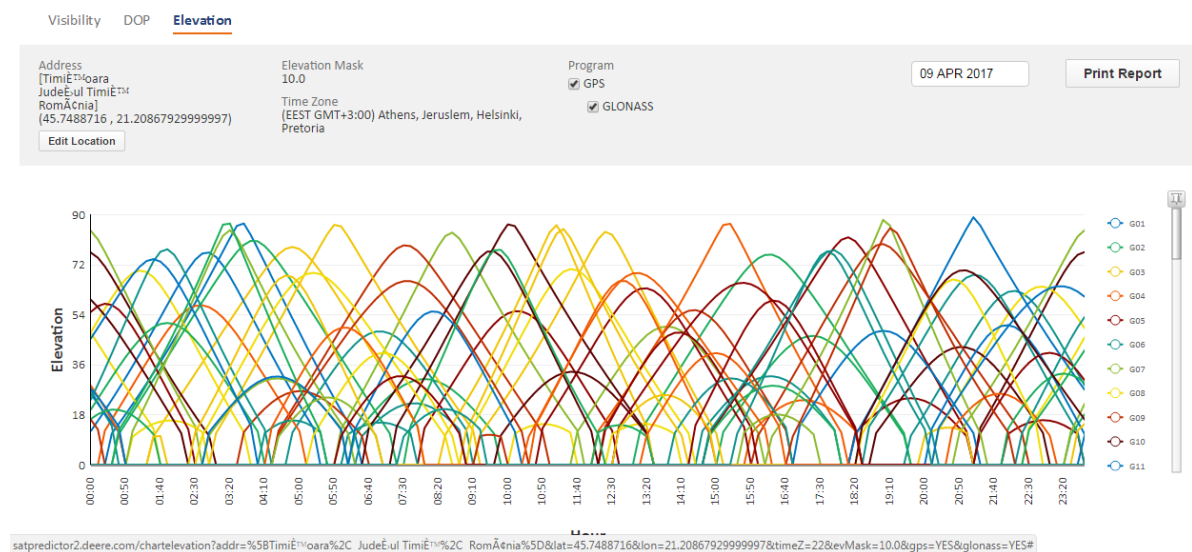

Fig. 4. Number of visible satellites [4]

GNSS observations to determine the point's position in Real Time Kinematic have been collected using measurements realized with Trimble R10 GNSS receiver.

Regarding the observations effected, they should reflect measurement accuracy, therefore estimates for determining the travel time of the radio signal from the satellite to the receiver are used in order to eliminate the influence of ionosphere combinations (Pseudo-Random Noise – PRN) (Fig.5).

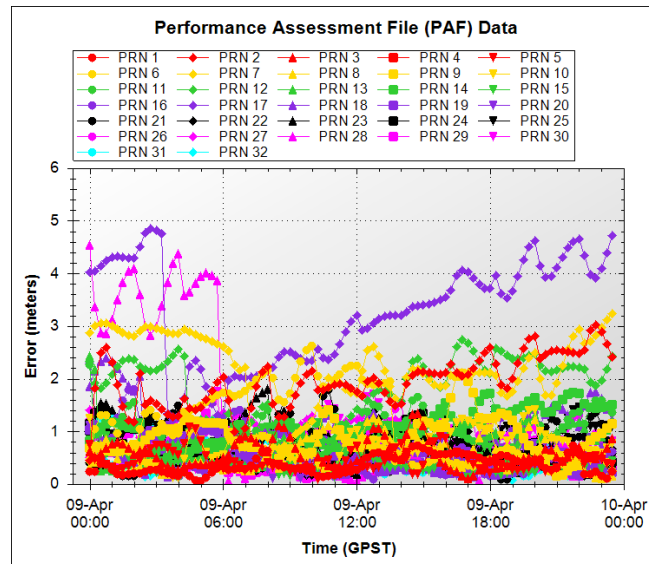

Fig. 5. Pseudo-Random Noise [6]

In addition, in order to avoid disturbances from the satellite signals which are transmitted through large distance throughout the atmosphere and to obtain points determination errors in different time periods, the elevation angle has been set in the GNSS receiver to 100, respectively 200 (Fig.6).

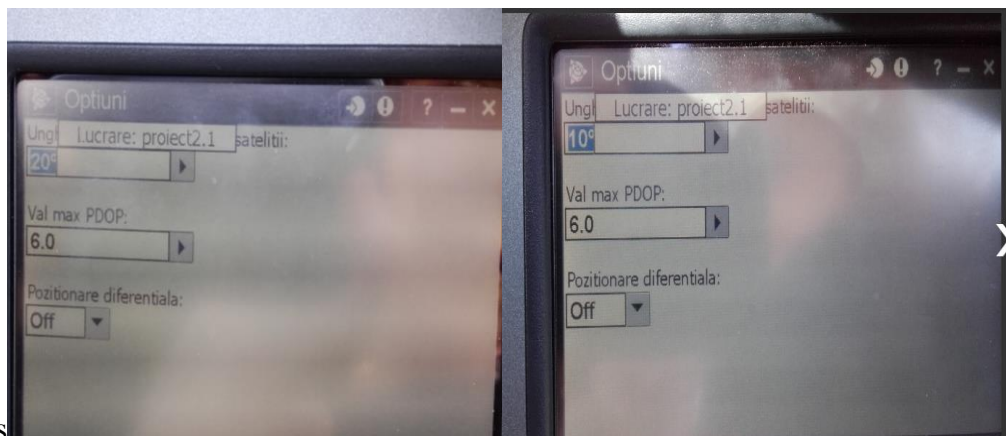

Fig. 6. Setting the elevation angle of the GNSS receiver

During the GNSS observation, the elevation angle of visible satellites, depending on the set value, has been permanently observed (Fig.7).



a) b)

Fig. 7. Elevation angle of visible satellites, depending on the elevation angle set: a) when elevation angle was set 100 and b) when elevation angle was set 200

RESULTS AND DISCUSSION

The results of points' determinations in crowded environments according to the GNSS measurements report reflect in Table 1 internal measurements accuracy of the receiver.

Table 1. GNSS measurement report

Angle below which use satellites	20	Val max PDOP	6						
Point	500	ΔX	2502.438	ΔY	942.289	ΔZ	-2634.033	Cod	pct
QC1		PDOP	2.4	GDOP	3.3	HDOP	1.3	VDOP	2.0
QC2		VCV xx (m ²)	0.000488	VCV xy (m ²)	0.000167	VCV xz (m ²)	0.000353		
				VCV yy (m ²)	0.000146	VCV yz (m ²)	0.000162		
						VCV zz (m ²)	0.000492		
Angle below which use satellites	20	Val max PDOP	6						
Point	502	ΔX	2502.320	ΔY	942.226	ΔZ	-2634.030	Cod	pct
QC1		PDOP	4.4	GDOP	6.7	HDOP	1.5	VDOP	4.2
QC2		VCV xx (m ²)	0.002914	VCV xy (m ²)	0.001536	VCV xz (m ²)	0.002597		
				VCV yy (m ²)	0.001277	VCV yz (m ²)	0.001656		
						VCV zz (m ²)	0.003677		

Based on the realized research we can conclude that the accuracy and reliability of GNSS technique, namely RTK used for determining points in crowded urban areas decreases dramatically when the cut-off angle of elevation increases.

CONCLUSION

Points determination accuracy and reliability in urban agglomerate using GNSS technology dramatically decreases when the elevation cut-off angle increases, particularly for cinematic applications. But for Real Time Kinematic determinations using multiple GNSS systems, vertical accuracy gradually decreases with the increasing elevation angle, but it is preferred to solutions with a single system.

In Satellite Geodesy refraction plays an important role because it generates variations in the speed of propagation of GNSS signals thus directly influencing its time propagation measurement. The positioning problem in crowded spaces or areas with obstructed satellite signals represents a geodetic

problem concerning a wide range of scientific areas for various GNSS applications. This affirmation can be confirmed by choosing different GNSS methods and testing elevation angle cut off in order to generate future necessary data for statistical analysis.

REFERENCES

- [1] Wieser, A., Gaggl, M., Improved Positioning Accuracy with High-Sensitivity GNSS Receivers and SNR Aided Integrity Monitoring of Pseudo-Range Observations, ION GNSS 18th International Technical Meeting of the Satellite Division, 13-16 September 2005.
- [2] Karbon, M., Biihm, J., D. Wijaya D., Schuh, H., Atmospheric Effects on Gravity Space Missions, 159 Springer Atmospheric Sciences. DOI: 10.1007/978-3-642-36932-2_5, 2013.
- [3] Koomen, E., Diogo, V., Assessing potential future urban heat island patterns following climate scenarios, socio-economic developments and spatial planning strategies, Mitigation and Adaptation Strategies for Global Change, 2017, 22:287–306, DOI 10.1007/s11027-015-9646-z.
- [4] <http://satpredictor2.deere.com>.
- [5] <https://search.earthdata.nasa.gov>.
- [6] <http://navigationservices.agi.com/GNSSWeb>

ANALYSIS OF PHOTOVOLTAIC SOLAR PANEL EFFICIENCY

Marija Stankov¹, Nataša Dabić¹, Ivan Palinkaš¹, Dušanka Milanov¹

¹University of Novi Sad, Technical Faculty „Mihajlo Pupin, Zrenjanin, Serbia

e-mail: marijap988@gmail.com

Abstract: Solar energy, as an alternative energy source can be exploited without causing harmful effects on the environment. From the environmental point of view, usage of photovoltaic solar systems (PV systems), which is the main topic of this paper work, is acceptable mostly because it doesn't produce pollution related to exploitation and usage of fossil fuels. The main point of this paper work is to show possibility of using PV solar systems on a practical example.

Key words: photovoltaic energy, practical usage, environment

INTRODUCTION

Increase of human population is the main reason which is disturbing the environment quality, and according to many researchers, this increase is taking terrifying dimensions – if the world population keeps doubling on every 50 years (by some projections on every 33 years), it would mean that in already 100 years the world population would be in around 18 000 000 [1]. Renewable energy sources have significant potential for development promotion of human kind. Energy which is obtained from renewable sources (water, wind, Sun, biomass, etc) could provide an access to clean and safe energy to millions of people. This kind of energy could give an incentive for social and economic development, which could help society to fight with environmental problems, and also has a main role when it comes to dealing with climate change [2]. Solar energy represents energy of Sun radiation which manifests on Earth in the form of heat and light.

MATERIAL AND METHODS

Photovoltaic solar panels are made of solar (photovoltaic) cells, which are in charge of electricity generation by direct conversion of photon energy of the Sun into electric energy. PV module (PV panel) is the smallest replaceable unit in PV string. Electrical output of the module (output voltage and output current) depends of the size and number of cells, their electrical interconnection and external conditions which is panel exposed to. PV panels exist in many shapes and sizes, and they can be made of different types of materials, but most often in usage are panels of “glass plates” that contains 36 PV cells connected in series so they could provide appropriate voltage (12V) for battery charging (accumulator). PV panels may have an individual metal frame, or they can be protected with rubber seal because they are mostly intended to be installed in a bigger montage system that contains several modules (panels) [3].

Monocrystalline solar panel

Monocrystalline solar panels are made of monocrystalline solar cells. Silicon (Si) solar cells are commercially most represented. In monocrystal of Silicon (Si), atoms are forming a complex cubic lattice – each Si atom is bounded with four other atoms over his four valence electrons. In this way, interconnection between two atoms is enabled by two electrons, which is called covalent chemical bond. Due to crystal heating, this covalent bond is breaking and electrons are releasing – transition from valence to conductive zone. Due to the electrons transition there comes to an “empty space” in valence zone, and this “empty space” is so called current carrier – similar to electron but with opposite electrification [4]. Monocrystalline Silicon is black, opaque, very shiny and, firm and weak electric current conductor (by adding additives it becomes a good electric current conductor). This type of solar cells, with the panel surface of 1m², is able to convert 1000 W/m² Sun radiation into 140 W electrical energy. The main advantage of monocrystalline Si solar cell is her high efficiency. The lifespan of this type of cells is 20 years and over [5].

Experimental measurements

PV solar panel that contains 24 monocrystalline Si cells is made due to experimental purposes (Fig. 1). Cells are serial connected in four series over the output (which are the voltage busbars) – six cells are connected, and output electrode of one cell is connected on the input electrode of other cell, and then all series are connected in parallel.

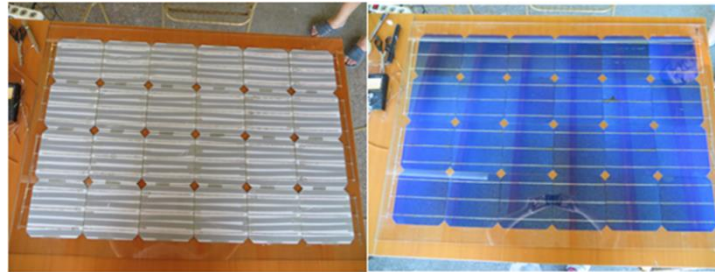

Fig. 1. Solar panel during it's construction

Measurements were performed by devices: *Sollar charge controller* (the output voltage [V] regulating device) and analog ammeter – amperage device [A], which are shown on the following pictures (Fig. 2 and Fig. 3).



Fig. 2. Sollar charge controller



Fig. 3. Analog ammetar

Considering that PV solar panel is able to produce electrical energy only when he is directly exposed to the Sun radiation, in order to use this energy later (example: during night) it is necessary to connect him with an accumulator. Consumers (light bulb and mobile phone charger) are also connected on this system due to measurements and results. Equation 1 is used in order of calculating the useful power gained:

$$P = U \cdot I [W] \quad (1)$$

wherein:

P – useful power [W];

U – optimal voltage [V];

I – amperage [A].

RESULTS AND DISCUSSION

The measurements were performed for 15 days (Jun 15 – Jun 29, 2020), every day between 07 – 19h (frequency: 2h) with different orientations of PV panel. During this time panel was set in three different positions: horizontal $\beta=0$, with an angle of inclination $\beta=24^\circ$, with an angle of inclination $\beta=38^\circ$. Panel orientation in all of the three positions is south, which means that the deviation angle from the south is $\alpha=0$. In the following tables (1-15) are shown data gained during the measurements of output voltage, so as maximal useful power:

- in Fig. 4-8 panel position: angle of inclination 38° ;
- in Fig. 9-13 panel position: angle of inclination 24° ;
- in Fig. 14-18 panel position: horizontal.

The main goal of measurements, due to inconvenient meteorological parameters, is establishing the working principle of PV panel which is made for experimental purposes.

Table 1. Measurement results Jun 15, 2020

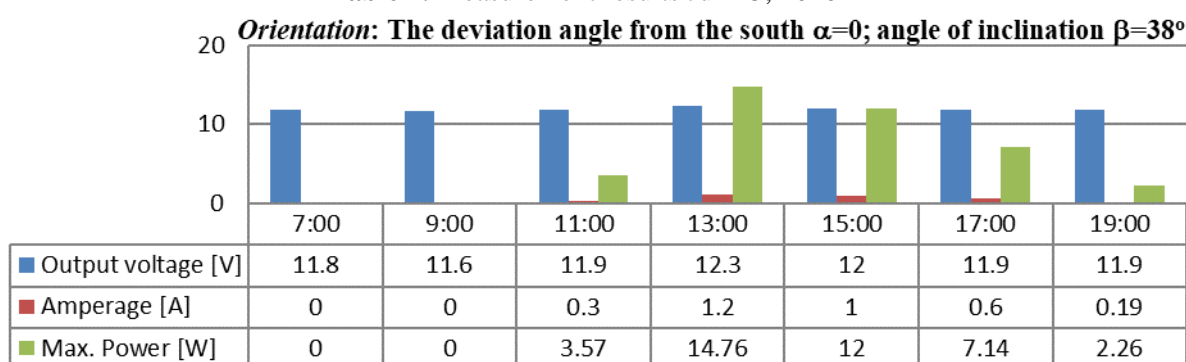

Table 2. Measurement results Jun 16, 2020

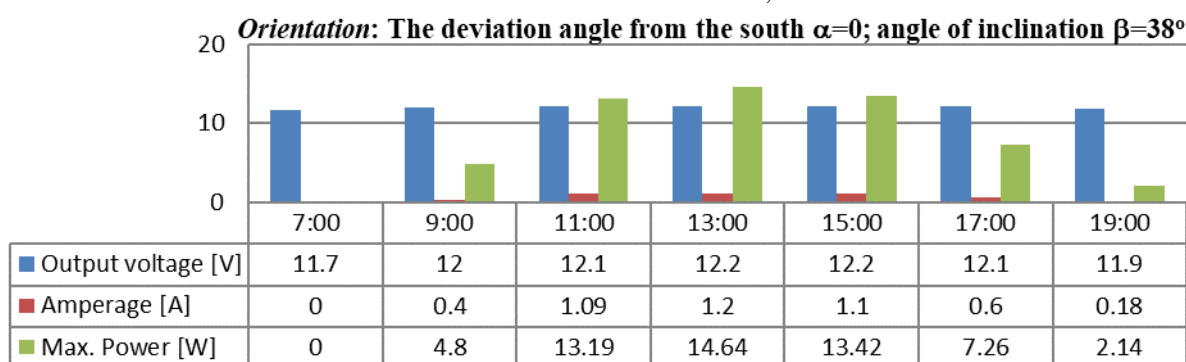

Table 3. Measurement results Jun 17, 2020

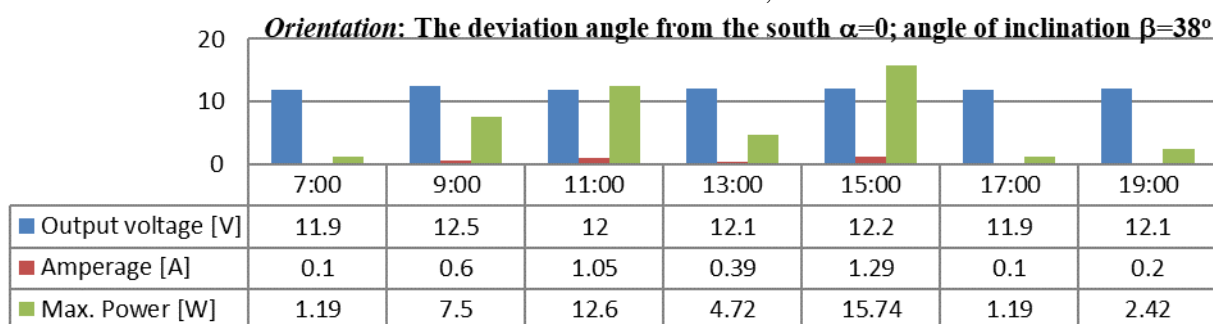

Table 4. Measurement results Jun 18, 2020

Orientation: The deviation angle from the south $\alpha=0$; angle of inclination $\beta=38^\circ$

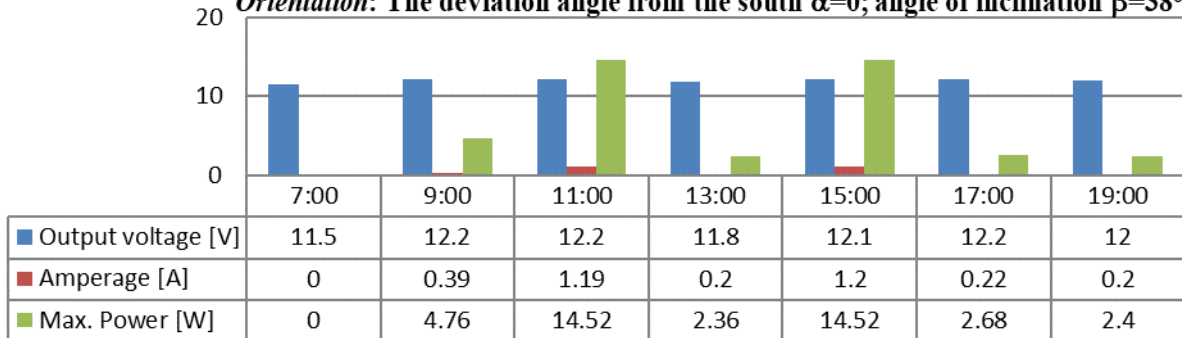

Table 5. Measurement results Jun 19, 2020

Orientation: The deviation angle from the south $\alpha=0$; angle of inclination $\beta=38^\circ$

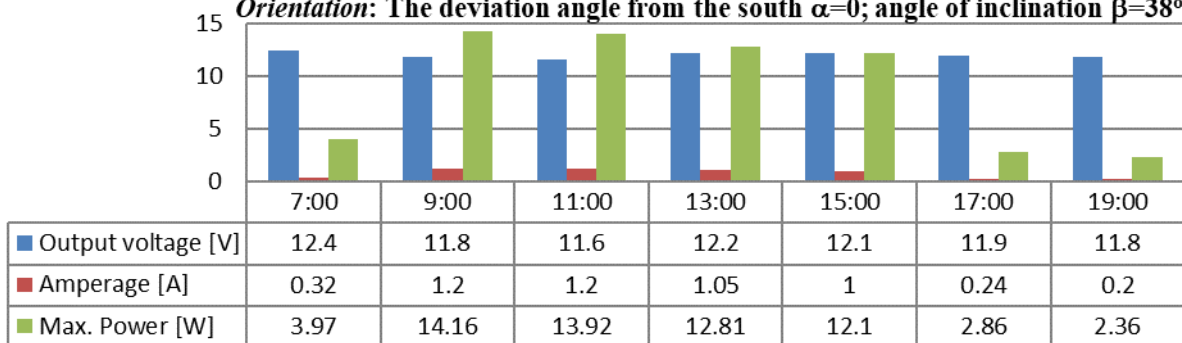

Table 6. Measurement results Jun 20, 2020

Orientation: The deviation angle from the south $\alpha=0$; angle of inclination $\beta=24^\circ$

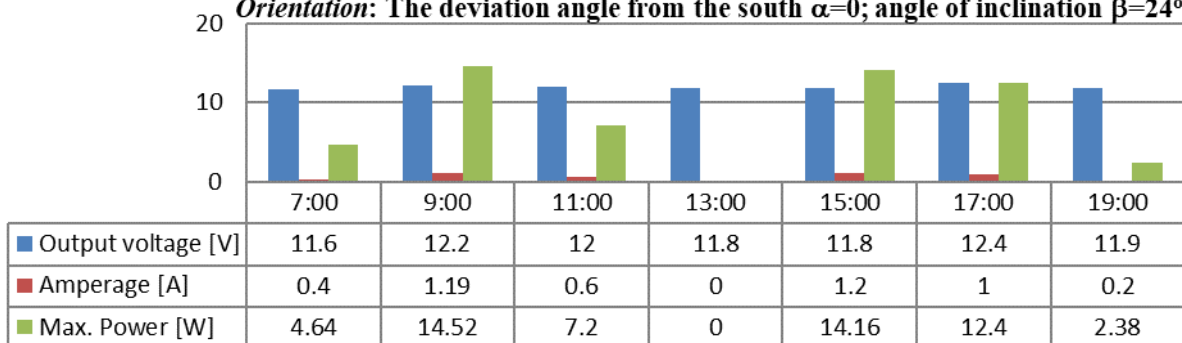

Table 7. Measurement results Jun 21, 2020

Orientation: The deviation angle from the south $\alpha=0$; angle of inclination $\beta=24^\circ$

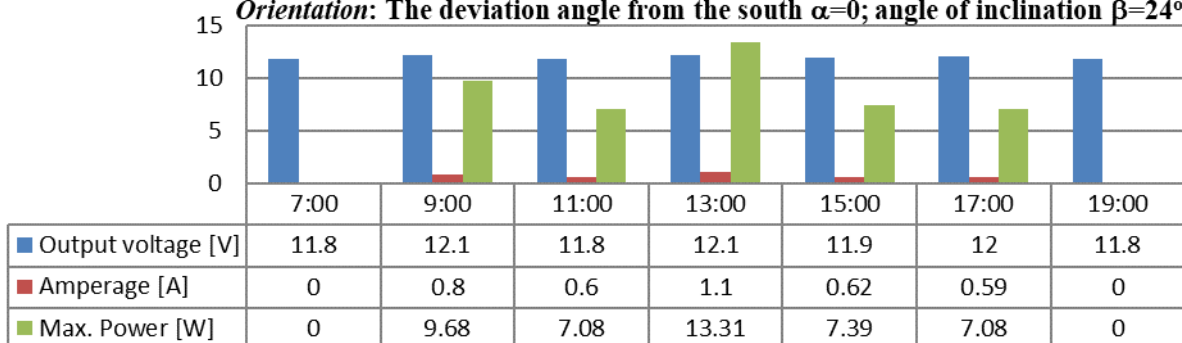

Table 8. Measurement results Jun 22, 2020

Orientation: The deviation angle from the south $\alpha=0$; angle of inclination $\beta=24^\circ$

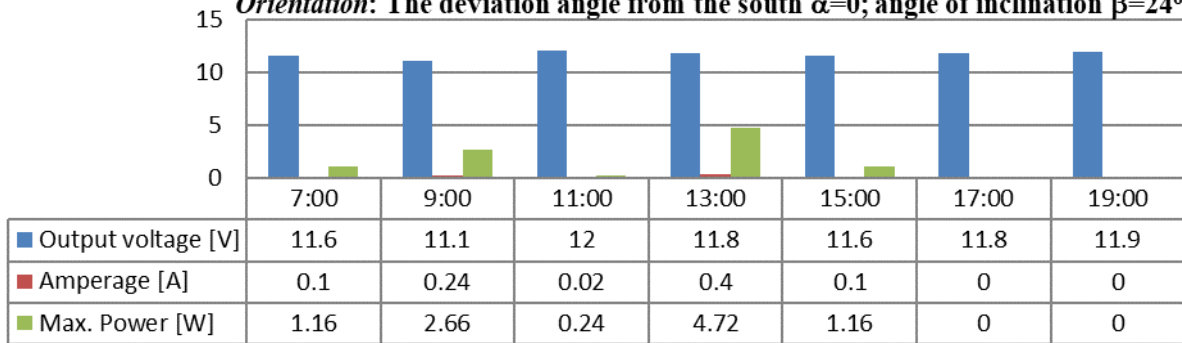

Table 9. Measurement results Jun 23, 2020

Orientation: The deviation angle from the south $\alpha=0$; angle of inclination $\beta=24^\circ$

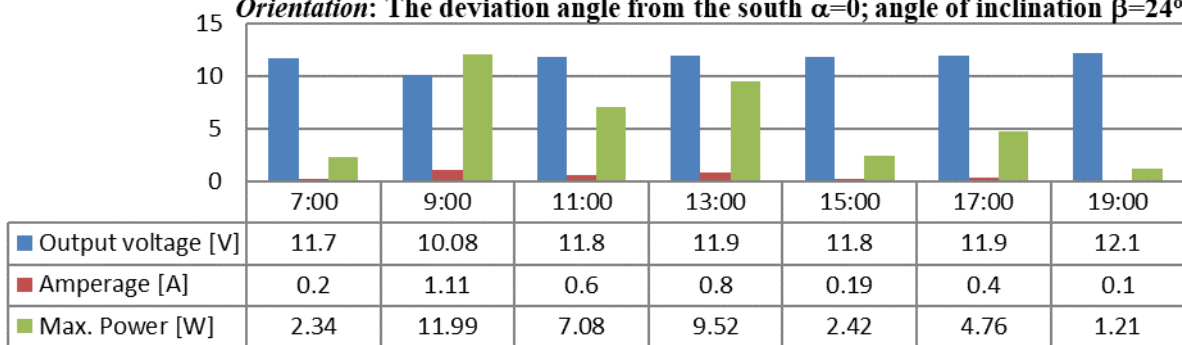

Table 10. Measurement results Jun 24, 2020

Orientation: The deviation angle from the south $\alpha=0$; angle of inclination $\beta=24^\circ$

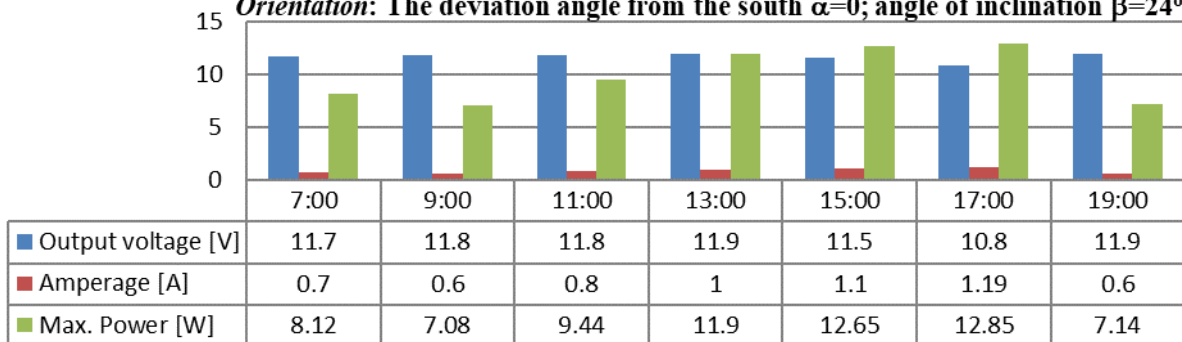

Table 11. Measurement results Jun 25, 2020

Orientation: The deviation angle from the south $\alpha=0$; angle of inclination $\beta=0^\circ$

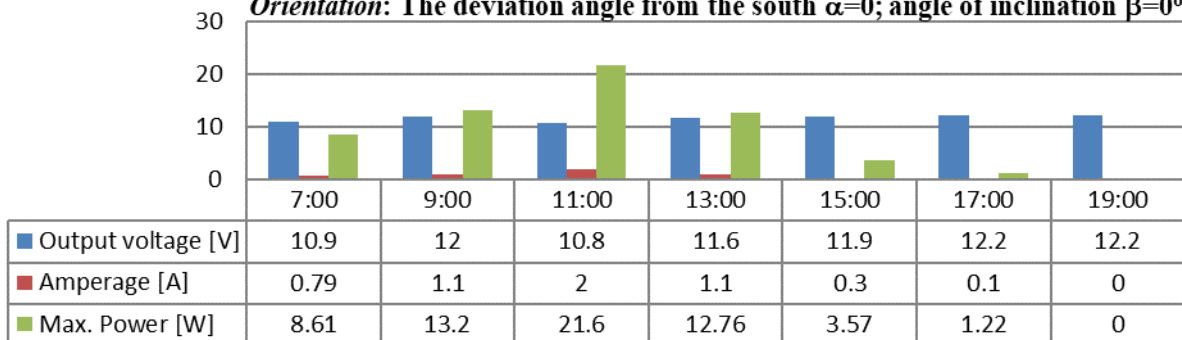

Table 12. Measurement results Jun 26, 2020

Orientation: The deviation angle from the south $\alpha=0^\circ$; angle of inclination $\beta=0^\circ$

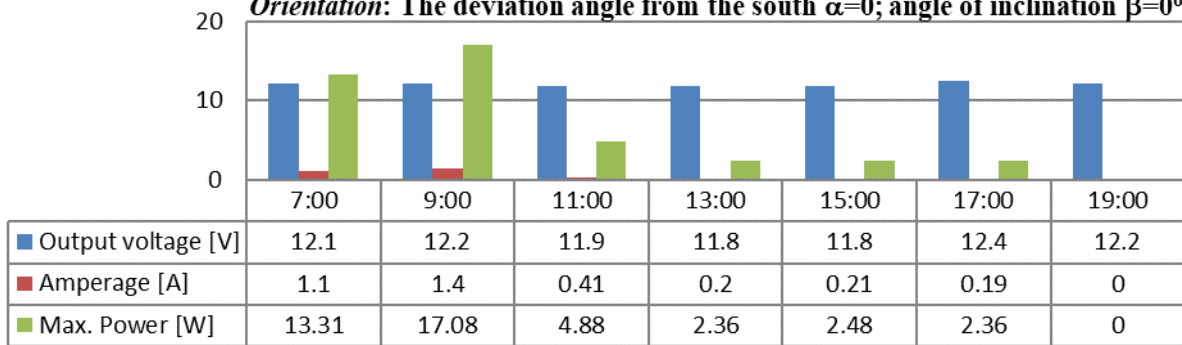

Table 13. Measurement results Jun 27, 2020

Orientation: The deviation angle from the south $\alpha=0^\circ$; angle of inclination $\beta=0^\circ$

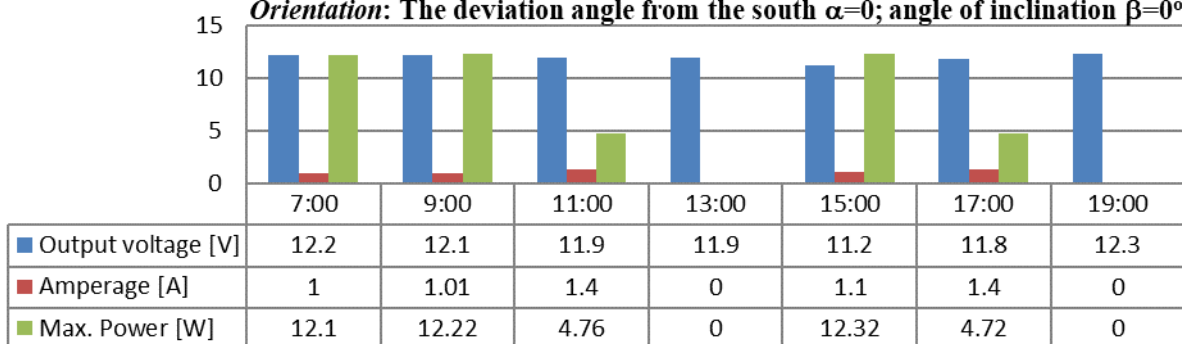

Table 14. Measurement results Jun 28, 2020

Orientation: The deviation angle from the south $\alpha=0^\circ$; angle of inclination $\beta=0^\circ$

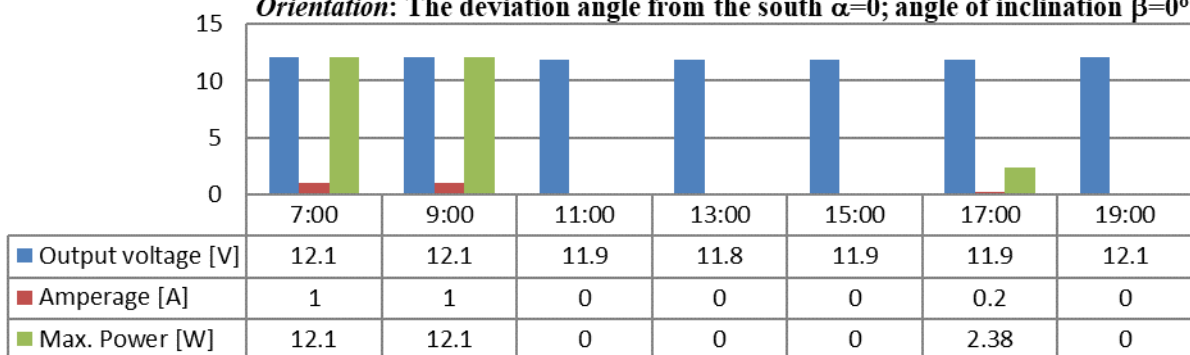
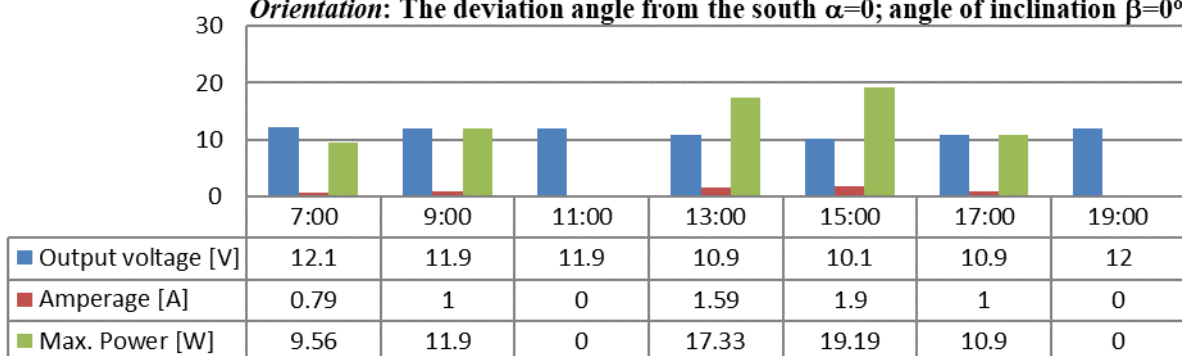

Table 15. Measurement results Jun 29, 2020

Orientation: The deviation angle from the south $\alpha=0^\circ$; angle of inclination $\beta=0^\circ$



Simulation results

PV GIS is a web application which provides solar radiation data access as well as possibility of producing electric energy using PV solar panels on any location all around the world. In this paper work, simulation is shown for location of PV solar panel where the experimental measurements were performed, which is Lazarevo, located on $L = 45,389^\circ$ latitude and $20,538^\circ$ longitude. Simulation of Sun radiation and potentially generated energy was done for each one position of solar panel during the measurement of the output voltage and amperage, which is shown in Fig. 4-9.

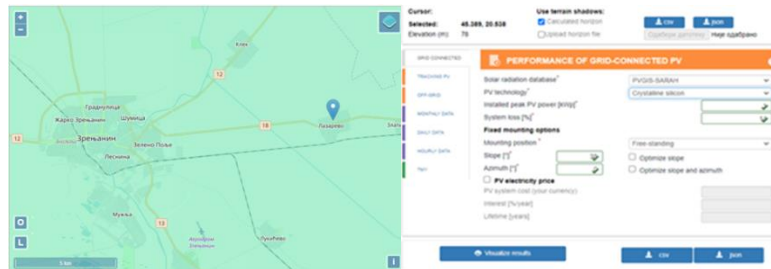

Fig. 4. Setting of the location and angle of the receiver - 38° in PV GIS



Fig. 5. Simulation of monthly radiation in plane with PV panel and simulation of generated energy with fixed angle of PV panel

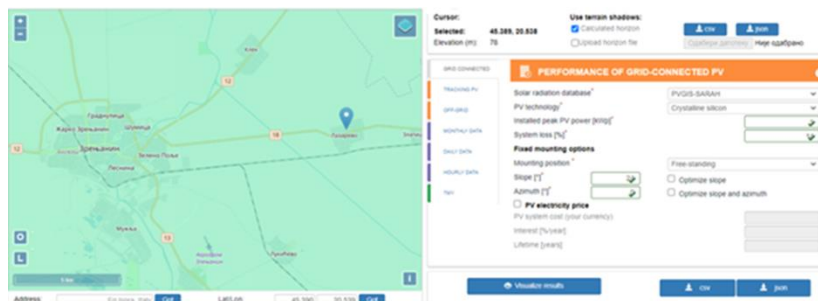

Fig. 6. Setting of the location and angle of the receiver - 24° in PV GIS

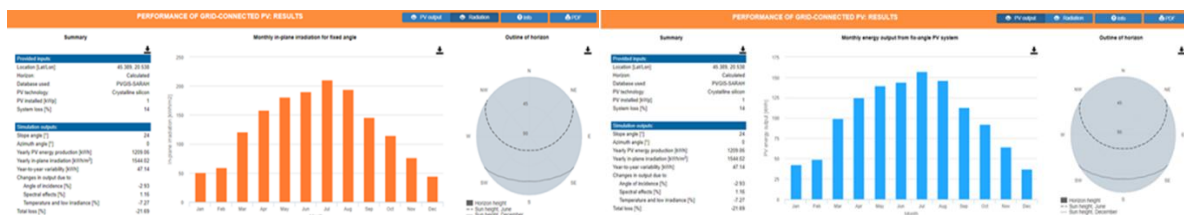

Fig. 7. Simulation of monthly radiation in plane with PV panel and simulation of generated energy with fixed angle of PV panel



Fig. 8. Setting of the location and angle of the receiver - 0° in PV GIS



Fig. 9. Simulation of monthly radiation in plane with PV panel and simulation of generated energy with fixed angle of PV panel

Simulation results are showing the potential electrical energy annual production provided by PV solar panel which amounts 1228,82 kWh (panel position with an angle of inclination 38°), 1209,06 kWh (panel position with an angle of inclination 24°) and 1053,28 kWh (horizontal panel position). In all of the three cases PV panel is south oriented and in a fix position.

CONCLUSION

Considering provided results, it can be concluded that the PV panel is most efficient in a position with an angle of inclination 38° because he is closest to an optimal capture of Sun energy on annual level. Further research will determine if PV panel made for realistic conditions research, including the measurements of meteorological parameters, could produce electrical energy amount provided by simulation for geographical position of his location as well as how much are the deviations.

REFERENCES

- [1] Crnogorac Č., Spahić M., Osnovi geoekologije, Artprint Banja Luka, 2012. pdf.
- [2] Obnovljivi izvori energije, Vodič za parlamentarce, Climate Parliament, www.rs.undp.org
- [3] Živković B., Solarni paneli, Sve što ste želeli da znate, Volta Technology 2019., pdf
- [4] Lambić M., Energetika, Tehnički fakultet Mihajlo Pupin, Zrenjanin, 2006.
- [5] Jaćimović A., Fotonaponski sistemi, FTN Čačak, master rad, 2011/12. Pdf.

PHARMACEUTICAL WASTE DISPOSAL PRACTICE AMONG THE CITIZENS IN THE MUNICIPALITY OF ZRENJANIN

Eleonora Terečik¹, Una Marčeta¹, Jelena Mičić², Višnja Mihajlović¹

¹University of Novi Sad, Technical Faculty “Mihajlo Pupin”, Zrenjanin, Serbia

²University of Novi Sad, Faculty of Technical Sciences, Novi Sad

e-mail: elaterecik5@gmail.com

Abstract: Pharmaceuticals are a potential source of a various compounds with different long-term or short-term effect on human health or environment. Improper disposal of unused medicaments is a growing problem worldwide. It has multiple negative effects on public health, the environment, and the costs. The main goal of scientific paper is to review and thoroughly analyze the current situation of pharmaceutical waste management in the municipality of Zrenjanin. In addition, the knowledge and practice related to expired drugs is analyzed, and potential indicators are identified. Further, the paper presents the most common final pharmaceutical waste disposal method in the municipality of Zrenjanin. The study also indicates that there is a need for stronger control of the implemented and legally defined procedures for drug disposal. Finally, a proactive education of the population on proper disposal of drugs is recommended.

Key words: pharmaceutical waste, drug disposal, expired drugs, pharmacy, waste, environment.

INTRODUCTION

The development of the pharmaceutical industry and the aging population on Earth have led to the widespread production and use of drugs, which caused an increase in the generation of pharmaceutical waste. It is estimated that even 90 percent of pharmaceutical waste is generated in the households. Although this type of waste is potentially toxic, and it requires special procedures for proper disposal. Unusable and expired drugs from households end up in municipal landfills, sewers, rivers, watercourses and sometimes even on flea markets [1]. This issue is serious, as storage of expired drugs in households is a common practice. The amount of drugs that is stored is approximately 0.28 kg per household member [2]. The unused household pharmaceuticals become waste, which, if not properly managed, poses a dangerous risk to the environment and human health.

Concerning the quantities of pharmaceutical waste, from all public health institutions and pharmacies, the total amount is estimated at 7,000 tons/year. In addition to this amount there is an additional 3,000 tons from the private sector, and up to 50 tons/year of additional pharmaceutical waste comes from households [3]. In the Republic of Serbia, current regulations regulate that pharmacies are obligated to collect unused drugs from citizens. In this case, the pharmacy that collects the pharmaceutical waste is responsible for its proper disposal. However, there are various types of pharmaceutical waste, and this is result from the following:

- pharmaceuticals and chemicals are discarded and unused,
- expired drugs,
- medicines that are unusable due to inadequate storage and handling,
- drugs that have to be postponed for other reasons [4].

The inadequate disposal of pharmaceutical waste is growing problem worldwide. It is becoming a health and environment risk. Studies from in the UK showed that only 22% of all unused drugs are returned to pharmacies. In the United States, the situation is similar with the return rate of 23%. However, these percentages are still significantly higher compared to 10 years prior, when only 2% of unused drugs were returned. For example, in New Zealand, studies show that the percentages of returned drugs are between 13 and 24% [5, 6].

The aim of the study is to analyze the practices and existing knowledge related to expired pharmaceuticals, and to identify methods of disposal used among the citizens in the municipality of Zrenjanin. In addition, the place of disposal of this type of waste is also considered. This research showed that almost 55% of the participants discarded expired drugs along with other household waste

with no primary selection. However, the participants have agreed that this practice is harmful for the environment.

MATERIALS AND METHODS

To develop this research, an online questionnaire was used for evaluating pharmaceutical waste disposal. The questionnaire was distributed on the territory of the municipality of Zrenjanin, and it was active for 6 days. In the research participated 136 respondents. The questionnaire included a total of 11 questions. The first three questions referred to the gender, age, and place of residence of the respondents. Other questions are as follows:

Q4: Pharmaceutical waste can be categorized as:

- a) Municipal waste (household waste)
- b) Medical waste
- c) Industrial waste

Q5: Whether pharmaceutical waste is hazardous waste?

- a) Yes
- b) No
- c) I am not sure

Q6: Can improper disposal of pharmaceutical waste negatively affect the environment?

- a) Yes
- b) No
- c) I am not sure

Q7: Does pharmaceutical waste require a different method of disposal?

- a) Yes
- b) No
- c) I am not sure

Q8: Where do you dispose of expired drugs?

- a) Nowhere, I keep it because I do not know where to discard it
- b) I throw it in the trash
- c) I take the drugs out of the package and pour it into the toilet
- e) I take it to the pharmacy

Q9: It is not appropriate to throw pharmaceutical waste from the household in the trash.

- a) Yes
- b) No
- c) I am not sure

Q10: Do you know where in your city you can dispose of pharmaceutical waste?

- a) Yes
- b) No
- c) I am not sure

Q11: If your answer was YES in the previous question, indicate where in your city you can dispose of pharmaceutical waste? (optional)

For the research, random sampling method was used. The questionnaires were distributed via social networks. Participants accessed the questionnaire through the link posted on social networks. The criteria for participants was based on place of residence (the participant must reside on the territory of the municipality of Zrenjanin) and age (participant has to be 18 or older).

RESULTS AND DISCUSSION

On Fig. 1, 2 and 3 the structure of the respondents in terms of gender, age and place of permanent residence is presented. On Fig. 1, when we look at the gender structure of the respondents, from the total of 136 respondents almost two thirds are women. More precisely, 83 are women (61%), and 53 are men (39%).

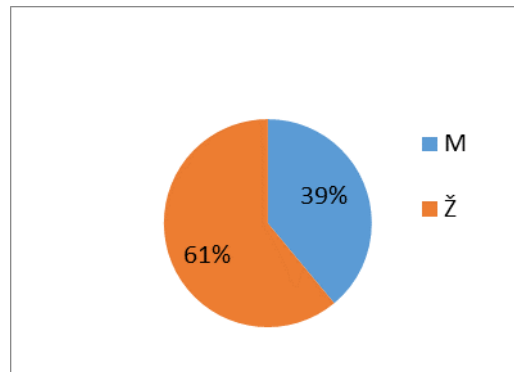

Fig. 1. Gender structure of respondents

Further, on Fig. 2, the age structure of the respondents is presented.

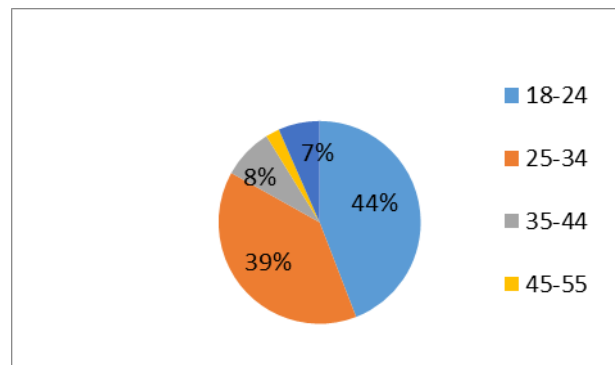

Fig. 2. Age structure of respondents

Regarding the age of the respondents, only people older than 18 years were eligible to participate in the research. The largest group of respondents (60 respondents) were the youngest and aged between 18 and 24. The next group of respondents (53 respondents) is the age in between 25 and 34. Further, 11 respondents are in the 35 to 44 years of age group, while 3 respondents are in the 45 to 55 years of age group. 9 respondents were older than 55 (Fig. 2.). The bias towards the younger population is due to the structure of social network users. Namely, the youth population are more active and present on social networks, therefore this online questionnaire reached a younger base of potential participants. Furthermore, according to the place of residence of respondents, the majority (94 participants) were from an urban environment, while the rest of the participants have residence in smaller surrounding villages in the municipality of Zrenjanin (Fig. 3.).

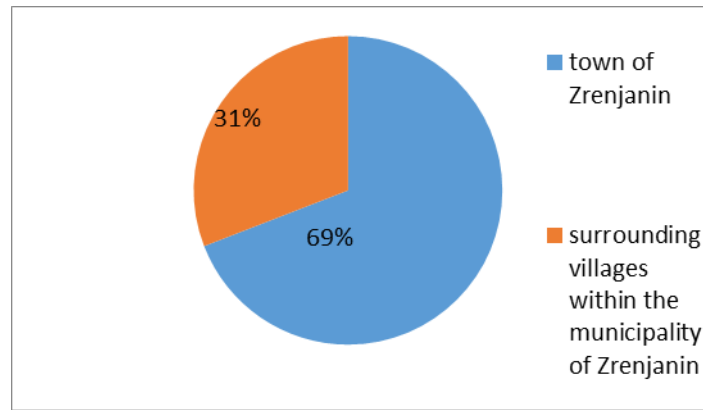

Fig. 3. Place of residence

Fig. 4 shows the answers to the fourth question, regarding the type of pharmaceutical waste. In this case, the majority of the participants (90%) answered that pharmaceutical waste can be classified as medical waste, and this is the correct answer.

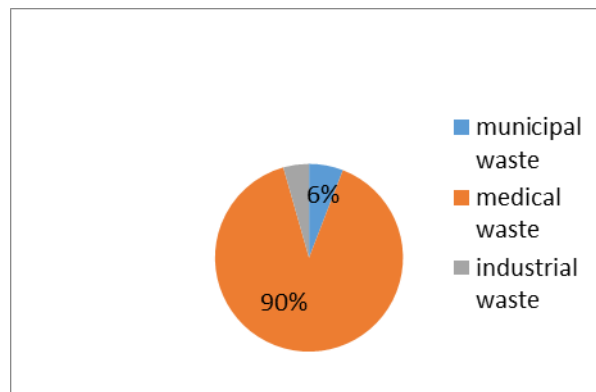

Fig. 4. Structure of the answers to the 4th question

The 5th question referred to whether pharmaceutical waste was hazardous waste. Here, 80% of respondents agreed that it belongs to hazardous waste, 16% of respondents were unsure and 4% of respondents thought it is not hazardous.

Furthermore, regarding the 6th question, more than 90% of respondents knew that improper disposal of pharmaceutical waste can have a negative impact on the environment (Fig. 5.).

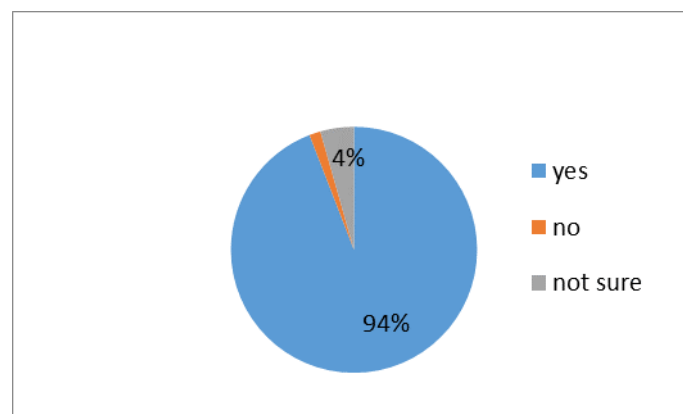

Fig. 5. Structure of the answers to the 6th question

The majority of the respondents (115) answered correctly to the seventh question, where it was asked if pharmaceutical waste requires a different way of disposal. Five respondents answered that it does not require special treatment, while 16 respondents were not sure (Fig. 6.).

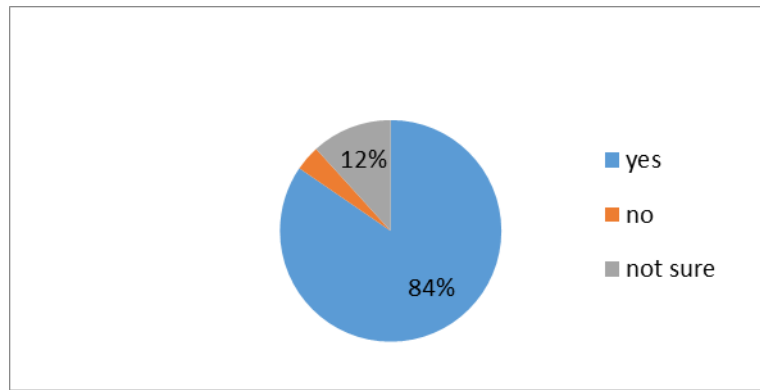

Fig. 6. Structure of the answers to the 7th question

For the eight question, where the disposal of pharmaceutical drugs was evaluated, more than half of the respondents (55%) answered that they throw it in the trash, about 23% return this type of waste to pharmacies, 12% keep it because they do not know where to discard pharmaceutical waste, and the other 10% take it out of the packaging and spill it in the toilet (Fig. 7.).

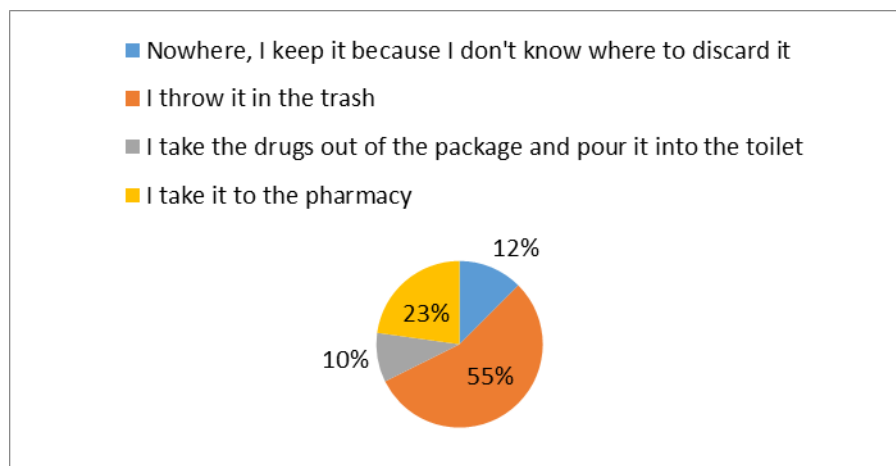

Fig. 7. Structure of the answers to the 8th question

In addition, 57% of the respondents agreed that it is not recommended to throw pharmaceutical waste in the rubbish bin, although most do so, while the rest of the respondents are not sure (Fig. 8.).

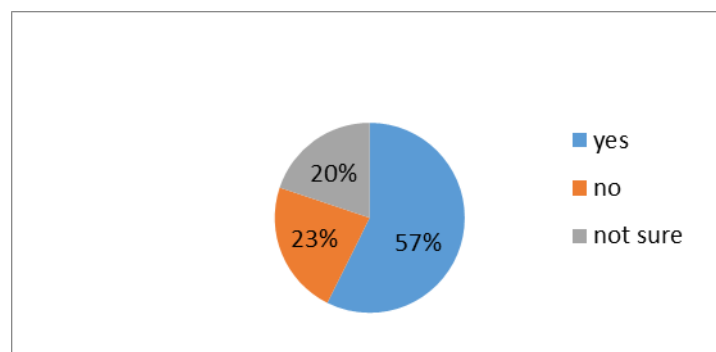

Fig. 8. Structure of the answers to the 9th question

Interestingly, 70% of Canadian households throw drugs in the sewers or garbage or even bury them instead of returning them to pharmacies. A similar situation was in Kuwait, where 87.7% of respondents threw drugs in the trash or spilled them [7]. In contrast, Sweden has a long tradition of returning unused drugs to pharmacies (since 1971). In Sweden, in 2001, 41% of respondents returned unused medicines to pharmacies and only 7% threw them in the trash. In a recent study, the percentage

of drugs dumped in the trash decreased to 3%, while the percentage of drugs returned to pharmacies increased to 43% [8].

To the 10th question: Do you know where in your city you can dispose of pharmaceutical waste? The most of the 136 respondents answered negatively, 15 (11%) of them answered positively, while the rest were unsure. Only 15 of the 136 respondents knew where to dispose pharmaceutical waste (Fig. 9).

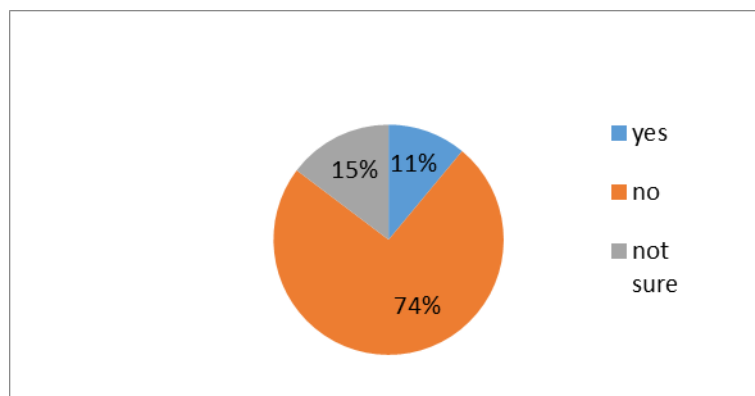

Fig. 9. Structure of the answers to the 10th question

The 11th and last question were optional for respondents who gave a positive answer to the previous question regarding if they knew where to dispose pharmaceutical waste. A total of 15 respondents answered, and among the answers were the company Remondis Medison from Zrenjanin and local pharmacies.

CONCLUSION

Disposal of household waste is one of the possible ways how pharmaceutical waste can enter the environment. Proper management of the pharmaceutical waste from households can reduce its negative impact on the environment. Current results indicate that improper drug disposal is still widespread and unused drugs are in general disposed improperly. Household pharmaceutical waste is simply disposed of as solid waste or discharged into the sewer system. In the municipality of Zrenjanin, according to the survey, the majority of the population are not adequately informed about the possibility of disposing of pharmaceutical waste. The most of the respondents in the municipality of Zrenjanin, mainly dispose unused medicaments in inadequate way. However, the respondents noted that they know that such a way of disposal is not recommended and it has a negative impact on the environment.

REFERENCES

- [1] O. Novitović, D. Randić, A. Novitović, Environmental Protection (srp. Zaštita životne sredine) Užice 2009
- [2] Guirguis K. Medications collected for disposal by outreach pharmacists in Australia. Pharm World Sci. 2010
- [3] Ugrinov D, Stojanov A, Legislative framework and competencies in the field of medical waste management (srp.Zakonodavni okviri nadležnosti u oblasti upravljanja medicinskim otpadom), 2013.
- [4] Law on Waste Management. Official Gazette of RS 36/2009 and 88/2010. (srp. Zakon o upravljanju otpadom. Službeni glasnik RS 36/2009 i 88/2010.)
- [5] Braund R, Peake MB, Shieffelbien L. Disposal practices for unused medications in New Zealand. Environment International 2009
- [6] Smith AC. Managing Pharmaceutical Waste-what pharmacists should know. Journal of the Pharmacy Society of Wisconsin. 2002

- [7] Abahussain EA, Ball DE, Matowe WC. Practice and opinion towards disposal of unused medication in Kuwait. *Med PrincPract.* 2006
- [8] Persson M, Sabelström E, Gunnarsson B. Handling of unused prescription drugs-knowledge, behaviour and attitude among Swedish people. *Environ Int.* 2009.

Session 6.

Environmental Management

AN APPLICATION OF DELPHI METHOD IN SELECTION OF HOSPITAL MANAGER

Ali Reza Afshari¹, Milan Nikolić²

¹Department of Industrial Engineering, Shirvan Branch, Islamic Azad University, Shirvan, Iran

²University of Novi Sad, Technical faculty "Mihajlo Pupin", Zrenjanin, Republic of Serbia
e-mail: afshari@mshdiau.ac.ir, mikaczr@sbb.rs

Abstract: Many scholars are exploring the use of multi-criteria decision analysis (MCDA) in health care decision-making. Managers in the hospital should have enough managerial skill to be coordinated with the complex environment. Manager selection as a considerable issue is complicated especially in hospital. The objectives of this study were to evaluate middle management skills in a healthcare. This study presents a methodology for the Hospital Manager selection problem, using Delphi method. The criteria, which are relevant to the hospital Manager selection, have been elicited through Delphi method. The model was tested on a case study in Mashhad, Iran and it was proven feasible in real world applications. This approach also enables decision-makers to better understand the complex relationships of the relevant attributes in hospital manager selection problems.

Key words: Hospital Managers Competencies; Hospital manager selection; Human resource management; Decision-making; Delphi method.

INTRODUCTION

Because Hospitals are complex organizations that require strong and effective management. The success of such organizations depends on the performance of managers. Managers play an important role in resource allocation, improving the quality of services and ultimately promoting the organizational performance [1]. The issue becomes more notable at the case of health care organizations dealing with human lives. The role of hospital managers is different from the role of managers of other organizations and industries. They both require similar skills and knowledge in management and organization development [2]. Therefore, the appropriate evaluation of managers plays a crucial role in the proper use of the costs and health promotion [3, 4]. Managers at all management levels should possess a comprehensive set of skills and competencies that enable them to deal effectively with the forces which represent opportunities and threats to an organization [1]. The challenge is that middle managers manage organizations and are therefore expected to possess specific management skills, particularly in this current competitive market. Research findings indicate that managerial skills, knowledge, and abilities are required for future success as a health care administrator in health care systems [5]. While the existence of an effective and efficient evaluation system is crucial for identifying talents and potential capabilities of managers, but unfortunately, no formal and systematic evaluation system has been applied to evaluate the candidates of hospital managers using rapid, informal and nonobjective assessment tools, would lead assessors to perform subjective evaluation [6].

Some MCDM techniques have been used in this process in the related literature. MCDM approach utilizes a score or utility factor, which is determined by decision makers for each criterion for each candidate. One of the initial steps in any multi criteria selection problem is identifying the selection criteria. Insight into the relevant literatures reveals that majority of the reviewed studies do not provide a systematic method for criteria selection. Current study aims to remedy this situation by offering a systematic method for eliciting criteria from panel of experts through some modifications in classic Delphi.

However, one of the most important steps in the evaluation process is definition of accurate and feasible criteria. In this regard, the skills required for hospital managers in healthcare organizations to effectively and competently perform their management roles need to be investigated. Querying experts during interviews in a group decision making at the same time is extremely difficult. The Delphi method [7], with anonymous questionnaires to avoid the effect of individual opinions, which helps experts to fully express their professional opinions, is an effective means of querying experts

to identify factors as criteria. Therefore, the Delphi method is used in this paper to determine the criteria. With literature review and expert interview, the study integrates the skills and competencies related to hospital manager selection and elicits the criteria of the experts' consistent opinions by Delphi method; The Delphi method is a proven technique commonly used in health research for curriculum and competency development [8].

MATERIAL AND METHODS

Hospital Managers Competencies

The importance of managerial competencies in monitoring and improving the performance of organizational leaders and managers is well accepted. Different processes have been used to identify and develop competency frameworks or models for healthcare managers around the world to meet different contextual needs [9]. There is agreement among practitioners and academics that managerial competencies are useful for monitoring and improving the performance of organizational leaders and managers, with useful application in healthcare [1]. Various studies have been done around the world in order to identify the competencies required for hospital managers [10]. For example, Pillay in his article defined a list of hospital management competencies in six categories. These related to People related skills, Health delivery, Self-management, Task related skills, Strategic management and Need for future health care management program [3]. MacKinnon et al. [11] classified these competencies in 9 categorized include Leadership, Communication, Lifelong Learning, Consumer/Community Responsiveness and Public Relations, Political and Health Environment Awareness, Conceptual Skills, Results Management, Resource Management and Compliance to Standards.

The Delphi method

The Delphi technique is an approach used to gain consensus among a panel of experts [12]. This is normally achieved through a series of rounds where information is fed back to panel members using questionnaires. It has been used extensively within social science research and is being increasingly employed by health researchers. This popularity has meant that the technique has been adapted in various ways. This signals the need for a critical review of the Delphi as a robust and systematic approach to data collection. While there is a great volume of literature surrounding the 'Delphi', there is a dearth of papers critically analyzing the technique [13]. The Delphi technique could achieve consensus of subject matter experts without bringing them together face-to-face to establish future criteria for hospital manager selection [13]. The Delphi method has become increasingly popular in recent years in health research. Particularly in studies attempting to reach consensus on curricula for health professional trainees or for continuing education, with many studies aiming to determine a list of core competencies to be implemented by training programs and institutions [14-18].

The Delphi method employed in the present study was modified from the typical process. Rather than having participants generate the initial competency list, the first round of Delphi participants were presented with an initial list of core competencies generated by the study authors from a literature review of relevant publications and existing core competency lists. Then participants were asked to make additions and provide feedback using this list as a starting point similar to the processes employed in Fletcher-Johnston, et al. [19]; Penciner, et al. [17]. The specific objectives of adopting Delphi method in this research were as follows:

1. Identifying future criteria required for hospital manager selection.
2. Determining a consensus of future criteria derived from the responses of the experts.

A total of 15 professionals served as the panel of experts for this study. The researcher contacted the potential panel members with a description of the study process with a panel member contact letter and an information sheet that stated that given the conditions provided, the completion and returning of the form to the researcher indicated consent to participate in the study. Potential panel members were provided with researcher contact information to answer any questions and asked to return the consent to participate form. A descriptive design using a three-round modified Delphi survey was used to meet the study objectives. The first survey questionnaire explained the issue in general terms with

examples and asked the panel members to provide input about the initial set of criteria. Responses from the first survey questionnaire were grouped together through a factor analysis and returned to the panel members in the second round. Using the information gathered in Round 1, the panel member's value rated the input provided in importance, using a numerical scale. The researcher summarized the numerical data input provided for the second survey questionnaire using the mean or average rating as a measure of central tendency. Panel members used a five-point Likert-type scale to indicate their value ratings for importance (Table 1). In each subsequent round, respondents were asked review their original responses and either retain them or change them based on the rationale and mean scores of all the participants from the previous rounds.

Table 1. Five-Point Likert-Type Scale Rating Importance

Rating	Definition (Linguistic Variable)
1	Very Important
2	Important
3	Neither Important Nor Unimportant
4	Unimportant
5	Very Unimportant

RESULTS AND DISCUSSION

The healthcare organization of the study is a public hospital located in Iran, Mashhad. Imam Reza Hospital is the largest center among referral centers in Mashhad. The first step in the process is to develop a team of related people who have knowledge and experience in healthcare management. This research was a qualitative study using thematic analyses that identifies and analyzes the themes related to aim of the study. Delphi panel of experts included 15 hospital managers and informant academic members. All participants must have had a degree in hospital management and at least 5 years hospital management experience. Another purpose of this stage was to identify criteria required for hospital manager selection. Once identified, the study would use the results in an attempt to determine a consensus of future criteria utilizing the responses of the hospital management experts. Using the derivative of this study, the criteria identified, the decision makers could use the results to develop a model to guide critical decisions of the future selection problem. The Delphi panel consisted of 15 members who were classified as Director of Mashhad University of Medical Sciences; three expert in hospital management; three members of Mashhad University of Medical Sciences, School of Environmental Health; Three faculty members of the Mashhad University of Medical Sciences; Three experts from Imam Reza hospital; and two other expert from another Mashhad hospitals.

Delphi Round One

For the first round survey, the panel members asked to complete an open-ended survey questionnaire by listing criteria they believed was required for a successful hospital manager in the future. They were also provided with the operational definitions for the study and asked to review the example of criteria. The panel members were also instructed to feel free to use the examples provided and anything else they thought appropriate. Although the panel members were provided with the above instructions, two of the panel members were still a small bit confused and needed a little more clarification about what was being asked. Even though, there were only two panel members with questions, the researcher believed that all of the questions received should be shared with all panel members along with the answers. The sharing of panel member questions and the responses was thought to only enhance the general understanding of the study for all involved. In the first round survey questionnaire, the number of criteria provided by the panel members varied per panel member. The responses included a large number of duplications, but oftentimes had a slightly different rationale for inclusion on the listing. All panel member surveys were accepted as submitted. The panel of experts provided 67 separate response items. Using a factor analysis, the responses were eventually combined resulting in 24 individual criteria for the remaining two rounds. The criteria were reduced to

24 in order to eliminate duplication and to provide for efficiencies in evaluating, analyzing, and reporting the data identified for each survey round.

Delphi Round Two

In Round 2, the responses received from the panel members in Round 1 and after a factor analysis were aggregated and returned to each panel member with the listing of criteria and a summary rationale statement generated from the survey results. The panel members were provided with Importance and were asked to please complete each spreadsheet by independently value rating each response using the five-point Likert-type scale. 22 out of the 24 or 91.7% of criteria that would be considered consensus. Out of the 22 criteria considered consensus, 17 or 77.3%, C3, C4, C5, C17, C6, C7, C8, C9, C10, C11, C12, C14, C15, C18, C19, C20, and C21 received the highest rating of 100.0% with a 1 = Critical or 2 = Very Important value rating. The 22 criteria considered consensus along with the percentage ratings for each one were displayed in Table 3. Table 3, also detailed the value ratings provided by the panel members' responses. The largest range of value ratings was C2 with a mean value rating of 2.7. C2 had a range value rating of 2 = Important to 5 = Very Unimportant. The highest mean value rating in this category was as also C2. The lowest mean value rating was 1.0. That distinction was held by C4.

Table 2. Criteria Considered Consensus –Round Two (N=15)

Criteria	Responses	Percent	Mean	SD
Meeting Criteria				
C ₃ : Conflict Resolution	15	100.0	1.1	0.35
C ₄ : Decision-Making	15	100.0	1.0	0.00
C ₅ : Delegation	15	100.0	1.7	0.49
C ₆ : Communication	15	100.0	1.1	0.35
C ₇ : Discipline	15	100.0	1.7	0.49
C ₈ : Staffing Strategies	15	100.0	1.7	0.49
C ₉ : Equanimity	15	100.0	1.7	0.49
C ₁₀ : Ethical principals	15	100.0	1.3	0.46
C ₁₂ : Humor	15	100.0	1.6	0.51
C ₁₄ : Involvement	15	100.0	1.8	0.41
C ₁₅ : Optimism	15	100.0	1.6	0.51
C ₁₇ : Perspective	15	100.0	2.0	0.53
C ₁₈ : Practice Standards	15	100.0	1.6	0.51
C ₁₉ : Prioritization	15	100.0	1.3	0.49
C ₂₀ : Problem solving	15	100.0	1.1	0.35
C ₂₁ : Productivity measures	15	100.0	1.9	0.26
C ₁₂ : Humor	15	100.0	1.6	0.51
C ₁₃ : Information systems	13	86.7	2.0	0.53
C ₂₂ : Research-based practices	13	86.7	2.0	0.53
C ₂₃ : Stress management	13	86.7	1.9	0.64
C ₂₄ : Teaching-learning theories	11	73.3	2.1	0.64
C ₁₆ : Organization of unit work	10	66.7	2.1	0.74
Not Meeting Criteria				
C ₂ : Budget Forecasting	7	46.7	2.7	0.82
C ₁ : Administrative Management	6	40.0	2.6	0.51

Delphi Round Three

Round Three represented the last round for surveying the panel members. The statistics and any consensus generated in this round would be considered final input. In Round 3, all responses received from the panel members in Round 2 were aggregated and were returned to each panel member, with the listing of criteria and a summary rationale statement generated from the latest survey results. The

panel members asked to please complete each spreadsheet by independently value rating each response using the five-point Likert-type scale. The utility function importance returned 23 out of the 24 or 95.8% of criteria that would be considered consensus. Out of the 23 criteria considered consensus, 15 or 65.2%, C3, C4, C5, C6, C7, C8, C9, C10, C12, C14, C15, C18, C19, C20, and C21 received the highest rating of 100.0% with a 1 = Critical or 2 = Very Important value rating. The 23 criteria considered consensus along with the percentage ratings for each one were displayed in Table 4. Table 4, also detailed the value ratings as provided by the panel members. The largest range of value ratings was C2 with a mean of 2.2. C2 had range value rating of 1 = Very Important to 5 = Very Unimportant. The highest mean value rating was C1 with 2.47. The lowest mean value rating of 1.1 was bestowed upon C4. The MUMS panel of experts returned 14 out of the 24 or 58.3% of attributes that would be considered consensus. Out of the 14 attributes considered consensus, 7 or 50.0%, administrative theories, conflict resolution, decision-making, effective communication, effective discipline, ethical principles, and problem solving received the highest rating of 100.0% with a yes value rating. The 14 personal attributes and competency clusters considered consensus along with the percentage ratings for each one were displayed in Table 3.

Table 3. Criteria Consensus – Round Three (N=15)

Criteria	Responses	Percent	Mean	SD	Required for Hire		
					n	Percent	
Meeting Criteria							
C ₃ : Conflict Resolution	15	100.0	1.2	0.41	15	100.0	Yes
C ₄ : Decision-Making	15	100.0	1.1	0.26	15	100.0	Yes
C ₅ : Delegation	15	100.0	1.7	0.49			
C ₆ : Communication	15	100.0	1.3	0.46	15	100.0	Yes
C ₇ : Discipline	15	100.0	1.6	0.63	15	100.0	Yes
C ₈ : Staffing Strategies	15	100.0	1.5	0.52	14	93.3	Yes
C ₉ : Equanimity	15	100.0	1.7	0.72	14	93.3	Yes
C ₁₀ : Ethical principals	15	100.0	1.1	0.35	15	100.0	Yes
C ₁₂ : Humor	15	100.0	1.9	0.64			
C ₁₄ : Involvement	15	100.0	1.7	0.49	12	80.0	Yes
C ₁₅ : Optimism	15	100.0	1.7	0.62	14	93.3	Yes
C ₁₇ : Perspective	13	86.7	1.7	0.46	14	93.3	Yes
C ₁₈ : Practice Standards	15	100.0	1.3	0.49	14	93.3	Yes
C ₁₉ : Prioritization	15	100.0	1.7	0.46			
C ₂₀ : Problem solving	15	100.0	1.2	0.41	15	100.0	Yes
C ₂₁ : Productivity measures	15	100.0	2.2	0.41	13	100.0	Yes
C ₁₁ : Financial Resource Procurement	14	93.3	2.3	0.46			
C ₁₂ : Humor	15	100.0	1.9	0.64			
C ₁₃ : Information systems	13	86.7	1.8	0.68	14	93.3	Yes
C ₂₂ : Research-based practices	13	86.7	2.2	0.56			
C ₂₃ : Stress management	13	86.7	1.9	0.59			
C ₂ : Budget Forecasting	12	80.0	2.2	0.94			
C ₂₄ : Teaching-learning theories	11	73.3	2.3	0.70			
C ₁₆ : Organization of unit work	10	66.7	1.9	0.35			
Not Meeting Criteria							
C ₁ : Administrative Management	8	53.3	2.5	0.74			

The 14 criteria identified and considered consensus in the category of MUMS required for utility function would be considered the minimum entry-level requirements for the hospital manager selection. Moreover, if the candidate possessed more than the 14 minimum entry-level requirements for the job position, this would suggest an even better candidate for selection.

CONCLUSION

The major contribution of this paper lies in the development of a comprehensive methodology, which incorporates diversified issues for the selection of a hospital manager. This study and its results suggested that the modified Delphi Technique could achieve consensus of subject matter experts

without bringing them together face-to-face to establish future personal attributes for the MUMS hospital manager selection. This study suggests that the Delphi technique can be used more widely within MUMS to assist them in their quest to maximize their resources and improve the service delivery system. This study clearly demonstrated that hospital manager selection process could be improved in several ways by implementing the fuzzy linguistic evaluation, group decision making, and Delphi method. The proposed methodology was applied to a large Iranian hospital as a case study, and the results are found to be satisfactory. The development of a fuzzy expert system as a decision support system to solve the problem of selecting hospital managers in medical sectors will be a research opportunity in the future.

REFERENCES

- [1] M. E. Stefl and C. Bontempo, "Common competencies for all healthcare managers: The healthcare leadership alliance model," *Journal of healthcare management*, vol. 53, no. 6, p. 360, 2008.
- [2] R. M. Shewchuk, S. J. O'connor, D. J. Fine, and J. L. Tyler, "Building an understanding of the competencies needed for health administration practice," *Journal of Healthcare Management*, vol. 50, no. 1, p. 32, 2005.
- [3] R. Pillay, "Managerial competencies of hospital managers in South Africa: a survey of managers in the public and private sectors," *Human Resources for Health*, vol. 6, no. 1, p. 4, 2008.
- [4] R. Pillay, "The skills gap in hospital management: a comparative analysis of hospital managers in the public and private sectors in South Africa," *Health Services Management Research*, vol. 23, no. 1, pp. 30-36, 2010.
- [5] J. Griffith, G. Warden, K. Neighbors, and B. Shim, "A new approach to assessing skill needs of senior managers," *The Journal of health administration education*, vol. 20, no. 1, pp. 75-98, 2001.
- [6] E. Dadgar, A. Janati, J. S. Tabrizi, M. Asghari-Jafarabadi, and O. Barati, "Iranian Expert Opinion about Necessary Criteria for Hospitals Management Performance Assessments," *Health promotion perspectives*, vol. 2, no. 2, p. 223, 2012.
- [7] C. Okoli and S. D. Pawlowski, "The Delphi method as a research tool: An example, design considerations and applications," *Information and Management*, vol. 42, no. 1, pp. 15-29, 2004.
- [8] N. Kumar, A. Swift, and E. Rahman, "Development of "Core Syllabus" for Facial Anatomy Teaching to Aesthetic Physicians: A Delphi Consensus," *Plastic and Reconstructive Surgery Global Open*, vol. 6, no. 3, 2018.
- [9] Z. Liang, P. Howard, S. Leggat, and T. Bartram, *Development and validation of health service management competencies*. 2018.
- [10] M. Stefl, "Report of the competency task force: Healthcare leadership alliance," *Chicago: HLA*, 2003.
- [11] N. J. MacKinnon, C. Chow, P. L. Kennedy, D. D. Persaud, C. J. Metge, and I. Sketris, "Management competencies for Canadian health executives: views from the field," in *Healthcare Management Forum*, 2004, vol. 17, no. 4, pp. 15-20: SAGE Publications Sage CA: Los Angeles, CA.
- [12] G. Brekelmans, R. F. Poell, and K. van Wijk, "Factors influencing continuing professional development: A Delphi study among nursing experts," *European Journal of Training and Development*, vol. 37, no. 3, pp. 313-325, 2013.
- [13] S. Keeney, F. Hasson, and H. P. McKenna, "A critical review of the Delphi technique as a research methodology for nursing," *International journal of nursing studies*, vol. 38, no. 2, pp. 195-200, 2001.
- [14] K. Godfrey, S. A. Haddock, A. Fisher, and L. Lund, "Essential components of curricula for preparing therapists to work effectively with lesbian, gay, and bisexual clients: A Delphi study," *Journal of Marital and Family Therapy*, vol. 32, no. 4, pp. 491-504, 2006.

- [15]M. Jirwe, K. Gerrish, S. Keeney, and A. Emami, "Identifying the core components of cultural competence: findings from a Delphi study," *Journal of Clinical Nursing*, vol. 18, no. 18, pp. 2622-2634, 2009.
- [16]L. Lock, "Selecting examinable nursing core competencies: a Delphi project," *International Nursing Review*, vol. 58, no. 3, pp. 347-353, 2011.
- [17]R. Penciner, T. Langhan, R. Lee, J. McEwen, R. A. Woods, and G. Bandiera, "Using a Delphi process to establish consensus on emergency medicine clerkship competencies," *Medical teacher*, vol. 33, no. 6, pp. e333-e339, 2011.
- [18]A. Twycross, "Achieving consensus about pain content for child branch curricula," *Journal of advanced nursing*, vol. 34, no. 1, pp. 51-60, 2001.
- [19]M. Fletcher-Johnston, S. Marshall, and L. Straatman, "Healthcare transitions for adolescents with chronic life-threatening conditions using a Delphi method to identify research priorities for clinicians and academics in Canada," *Child: care, health and development*, vol. 37, no. 6, pp. 875-882, 2011.

ENVIRONMENT PRESERVATION AND ACHIEVING COMPETITIVENESS WITHIN THE FRAMEWORKS OF SUSTAINABLE DEVELOPMENT

Mihalj Bakator¹, Dejan Đorđević¹, Ljiljana Đorđević²,
Srđan Bogetić³, Dragan Čočkalović¹

¹ University of Novi Sad, Technical Faculty "Mihajlo Pupin", Zrenjanin, Serbia

² Serbian Environmental Protection Agency, Republic of Serbia

³ Belgrade Business and Arts Academy of Applied Studies, Belgrade, Serbia

e-mail: mihaljbakator@gmail.com

Abstract: Economic activities are connected to social development as well as to the environment. When economic activities are intensified it affects social development, and more importantly, it can cause significant environmental damage. When it comes to achieving competitiveness, countries have different results regarding environmental protection and social developments. This is due to different policies and priorities implemented in long-term strategies. In this paper, achieving competitiveness within the frameworks of sustainable development is analyzed. The main goal of the paper is to concisely present the data and information on this topic. In addition, guidelines for improving environmental protection and sustainable development of the domestic economy are proposed. This way a solid basis for future studies is provided.

Key words: sustainable development, environment protection, domestic economy

INTRODUCTION

The environment is not independent from economic growth. With each economic activity and changes of economy metrics affect the community, the social environment and the natural environment as well [1]. The World Economic Forum noted and emphasized the necessity for integration of issues regarding social and economic development and the environment. In addition, it was also noted that these issues have to be addressed through a single agenda or strategy [2]. Further, the technological advancements of information-communication technologies (ICTs) within the framework of Industry 4.0 create an environment with many opportunities and challenges for enterprises. In such a dynamic business environment where the results of the fourth Industrial Revolution are present, enterprises have to apply advanced technologies in order to achieve and maintain competitiveness on the globalized international market. In 2008, the weaknesses of contemporary capitalism were revealed. This weakness and the results of the crisis dramatically affected the global economy. In the past decade, fierce dedication was outputted in order to stabilize the global economy. Today, business activities have to comply with the goals of sustainable development. More precisely, long-term economic growth has to be based on sustainability of social and economic factors, as well as on urgent environmental protection strategies [3]. On their Annual Meeting in 2020, the World Economic Forum launched a new Development Platform 2030. This platform focuses on building a strong and motivated private partnership and civil society with the goal to advance the ecosystem and to take advantages of future opportunities [4]. Countries who share similar levels of competitive ability, don't necessarily have similar results regarding environmental protection and social development. This is mainly due to the implementation and application of different priorities and policies regarding this issues.

In this current study, environment improvement and competitiveness amidst the new economic paradigm and within the frameworks of sustainable development is analysed. The main goal of the paper is to define guidelines for improving the environment and the concept of environmental protection within the mechanisms of sustainable development regarding competitiveness on a micro (enterprises) and macro-level (country). The paper includes three main sections (excluding the *Introduction* and *Conclusion* sections). The first section addresses the modern business environment in which enterprises have to adapt to a new economic paradigm. In the second section indicators regarding environment improvement of Serbia and the Western Balkans are discussed. The third

section discusses guidelines for improving the environment taken into consideration the necessity for competitiveness and the concept of sustainable development.

THE NEW ECONOMIC PARADIGM AND GLOBAL BUSINESS ENVIRONMENT

In the modern world the main risks are related to the environment. This is a rather broad concept, but in this paper's context the most commonly observed environment risk are extreme weather events, climate change, natural disasters and damage to the environment caused by humans (radioactive spills, toxic spills, oil spills etc.) [5]. Climate change has brought uncertainty. The World Economic Forum concluded that climate change besides the environmental aspect has an economic aspect as well, and represents an investment risk for investors [6]. However, if the economy and its impact are ignored, especially its impact on long-term development, then there is an increased possibility that the harmful effects of humans and enterprises on the environment won't be eliminated [7]. In the last decade developed countries faced an economic slowdown due to reduction in productivity growth. Now, in order to increase overall societal wellbeing a new growth paradigm is needed. This paradigm has to focus and aim towards linking social and economic factors in regards of environmental advancement. Natural resources, labour force, and equipment affect overall productivity and also results in the creation of income and value, as well as pollution. According to a broad view of sustainable development, the end result of conducting business should be the creation of products, services, new investments and instead of pollution, higher quality of life [8]. Further, the main elements of the sustainable development of enterprises include methods and tools, strategic objectives, factors, principles, and management based on sustainable materials [9].

In 1973 the World Economic Forum (WEF) published a manifesto which focused on management's commitment towards their employees. Today, as the world is at a critical crossroad, the WEF founder Klaus Schwab noted that there is necessity for new manifesto. The Davos 2020 manifesto's aim is to rethink the purpose of companies and governments, as this why the WEF was founded fifty years ago [10]. The Davos 2020 manifesto includes a set of ethical principles for managing enterprises in the age of the fourth industrial revolution - Industry 4.0. The whole document is based on approaches and principles including that enterprises should pay fair tax rates, apply zero tolerance for corruption, human rights support through global supply chains, and striving toward building a competitive economy [10]. In addition, it is important to activate enterprises to conduct business in a manner which will protect the environment. It is necessary to establish long-term business behaviour aimed towards sustainability in order to achieve economic and social developmental goals [11].

According to past experiences, warnings and appeals alone are not enough to reduce negative impacts on the environment. On the other hand, it is argued that the biggest strength of a market economy is that it affects the behaviour of individuals and enterprises [12]. Therefore, it is important to take advantage of this. More precisely, through the influence of the market economy it is necessary to transform transition economies into sustainable, developed economies, where there is a significant reduction of carbon dioxide emissions. For example, with consumers, prices are a dominant factor (prices can be optimized for eco-friendly products) while with enterprises the dominant factor are taxes (pollution tax can be introduced in a systematic way). This requires acting both on a national economy level and on a global economy level. Further, when it comes to sustainable development as a concept, information, qualitative and quantitative data play a crucial role in defining indicators [13].

Additionally, it is necessary to build and develop a new type of communication and leadership between employees and employers. The result of such improved communication should be the development and cooperation of new projects and investments in the domain of sustainable technologies. Further, the labour market has to focus on specific employees and not so much on jobs.

When it comes to production, as a mean of designing, consuming and completing product cycles, advanced technologies are necessary for higher production efficiency, for creating new value in the industry, and for creating value for society and the environment. Classical investments should be broaden with investments in employee education. These types of investments and new investments overall, open doors to opportunities from the aspect of R&D and increased production capacity [14]. From here, developing and manufacturing products which meet the needs of customers is the primary goal of conducting business. The enterprise conducts business with the main goal to achieve profits.

However, this goal has to be based on long-term satisfaction of customer needs and the wider community as well. Inclusive growth implies on creating jobs and reducing poverty.

ENVIRONMENT IMPROVEMENT IN 2019 - INDICATORS FROM SERBIA AND THE WESTERN BALKANS

When it comes environmental improvement, institutions are the one of the most significant factors of opportunities. In the report of the World Economic Forum and Global Competitiveness, institutions were analysed as the first pillar of competitiveness. Further, the possibilities of environmental improvement is directly related and influenced by government actions at its strategic orientation towards the future. As an integral part of the institutions' competitiveness pillar there are several determining factors including long-term vision, energy efficiency legislation, renewable energy legislation, and issues related legislation which addresses environmental hazards.

The first determining factor, long-term vision (mainly the government's vision), in Serbia ranked 80th in the world (out of 1414 countries covered by the report). Further, Serbia is ranked 75th when it comes to the government's ability to respond to changes in the environment. Serbia has a relatively good rank when it comes to energy legislation (34th). Lower ranks are reported in the domain of legislations related to renewable energy sources (6^{5th}), and in the domain of possible environmental threats issues (79th). Furthermore, in Table 1. a comparative overview of institutional impact on the environment and potential environmental hazards is presented for the Western Balkans Region for the 2019 year (latest data).

Table 1. Comparative overview of institutional impacts and potential environmental hazards in the Western Balkans Region (2019) [15]

Country	Global competitiveness rank	Long-term vision rank	Energy efficiency regulations rank	Renewable energy sources regulation rank	Environmental hazards rank
Bosnia and Herzegovina	92	138	-	-	132
Montenegro	73	79	-	-	79
Croatia	63	137	36	51	17
North Macedonia	82	119	-	-	126
Slovenia	35	97	-	-	11
Serbia	72	80	34	65	79

Based on the data from Table 1. all the countries have relatively low ranks when it comes to long-term vision from a governmental aspect and in relation to the aggregate of the global competitiveness index. Serbia and Croatia have a slightly higher rank when it comes to energy efficiency legislation. On the other hand, Slovenia and Croatia are significantly higher ranked when it comes to potential environmental hazards. This is mainly due to their obligation to follow EU legislations on this manner. The EU directives are more strict and focused when it comes to environmental protection. In contrast, Serbia, Bosnia and Herzegovina, Montenegro, and North Macedonia have lower ranks in the domain of environmental hazards. The share of renewable energy resource consumption can be an indicator, or better say a guiding criterion in relation to the situation in the domain of environment improvement. In Table 2. the percentages regarding the share of renewable energy sources in consumption for 2019 (newest data) are presented.

Table 1. Share of renewable energy sources in consumption for 2019 [15]

Country	Share of renewable energy sources in consumption
Bosnia and Herzegovina	40,8%
Montenegro	43%
Croatia	33,1%
North Macedonia	11,3%
Slovenia	20,9%
Serbia	21%

Enterprises developing and implementing new and advanced technologies in the environment preservation domain are in a direct relation with environmental protection and environment improvement. Enterprises who specialize in clean technology such as solar energy, wind energy, bio-fuels, bio-materials, water filtration, green buildings, intelligent networks, personal transportation etc.) are more often than not, on the top from the aspect of innovation and competitiveness. In the domain of clean technology, Serbia is ranked 83rd in the world (according to the WEF), while for example, Israel is the leader in clean-tech. Further, clean-tech enterprises often form and join into clusters to increase or maximize economic development and environmental impact. According to World Economic Forum report for 2019, Serbia is ranked 104th in world in regards to the development of clusters on a national level. Based on the data regarding growth rate of innovative enterprises and the development rate of clusters, which are the basis for the development of clean-tech focused enterprises, the domestic economy is relatively low-ranked - 72nd in the world, especially when compared to the majority of EU countries.

In addition, for improving the environment, stronger investments are an imperative. In the case of Serbia, the five-year average foreign direct investment (FDI) inflow to Serbia was 6.1% of the GDP. The average amount of FDI is not sufficient for developing or investing into clean-tech companies. Currently, this percentage share of FDI in GDP is the lowest in the region, and there the chances are slim for making any significant improvements. One of the main reasons for this is the very low level of private investments (FDI excluded). The development of clean technologies requires stronger investments and long-term investing strategies [16]. From here, regional centres should be formed and long-term incentive programs and subsidies for clean-tech development should be introduced.

GUIDELINES AND SUGGESTIONS FOR IMPROVEMENT

Guidelines for promoting environmental protection and in a broader view, for improving sustainable development in the domestic economy are:

- Improving environmental legislations
- Stronger investments in environmental protection
- Assisting communities on a local level in setting up clean-tech clusters
- Improving environmental education

Improving environmental legislation includes the necessity for stimulating and motivating action. This includes tax incentives for enterprises who regularly invest into protecting and improving the lives in their communities, and for enterprises who conducts stimulating action towards new investments in environmental protection and promotion (access to funds, non-commercial loans, etc.). Further, when it comes to investments, both domestic and foreign enterprises should be stimulated and motivated for their efforts and investments related to the application and development of clean technologies. Some of the most important instruments/mechanisms for developing clean-tech include the access to capital, quality labour force, clear vision, R&D support, and policies that support such clean-tech oriented business activities [17].

The government should develop and conduct strategies for assisting the formation of clusters in the field of clean technologies. This approach is important for enhancing innovation and for overall economic development. The clean technology sector has an crucial economic role as it acts as a job multiplier. Production in the clean technology sector requires more jobs compared to other technologies. Expanding the volume of investments through incentive programs and subsidies in the

domain of developing regional clean-tech centres is one of the key areas of action. Investments are necessary for innovation which is a key success factor for the entire high-tech sector including the clean-tech sector.

Clusters can be represented as a form of networking for small and medium-sized enterprises (SMEs). Now, in order to achieve long-term and effective strategies in the domain of clean-tech development (but also in other tech domains) it is necessary (and a challenge) to overcome national barriers which are created by cluster-forming countries. When these barriers are come down, regional clusters can be formed. Regional clusters can be viewed as a concentration of interdependent enterprises in one geographical area. These clusters are restricted to a geographical area and include a large number of enterprises which conduct business in a small number of related industrial sectors.

Furthermore, clusters can greatly vary in their competitive position and the intensity of their innovative activity. Therefore, there are clear differences between clusters whose activities are conducted in a traditional way (applying existing technology) and whose activities are based on science. Innovative clusters are based on science and the advancement of knowledge. They enhance the creation of new markets and represent technological generators in the domain where they conduct their activities. Clean technology clusters can viewed as innovative clusters.

Further, every country is considered to be valuable as the students it educates [18]. The clean-tech sector requires skilled professionals of various profiles (mathematicians, chemists, physicists, biologist, economists, engineers etc.) who can create new technologies that are forward-looking. Based on this, it is evident that the successful development of clean technologies can be achieved only with education programs which combine economics, engineering and environmental protection. This further implies that adequate cooperation between research institutes and universities on a local and national level is needed. Besides the investments into formal education, there is a need for continuous exchange of information between all interested parties in a non-formal setting such as round tables, forums, scientific meetings etc.

CONCLUSION

Based on the analysed data and literature in this domain, it is evident that in the future, achieving sustainable productive economic growth that will improve the lives of individuals. Governments and national economies should focus on creating conditions which are adequate for a wider application of modern technologies. Similarly, it is necessary to develop conditions where employees can contribute to the advancement and improvement of production and productivity. These advancements have to comply to the frameworks of the fourth industrial revolution - Industry 4.0. National economies and enterprises, especially global enterprises, have to establish a suitable model for sustainable economic growth. The main drivers of environmental protection and improvement action are the improvement of environmental legislation, stronger investments into environmental protection, assisting local communities in establishing clusters in the domain of clean-tech, and improvement of education in the field of environmental protection. In the modern business environment where the market is globalized, and new competitive relation dynamics are at play, it is an imperative to develop a new and modern approach to enterprise management (both in contextual and organizational aspects). Due to the changes happening in the business environment, enterprises have to modify and improve their approach toward quality management, technology management, and overall management. Peter Drucker [15] noted that results in a knowledge society were not given by an individual as an individual is a centre of cost rather that the centre which produces value and results. The enterprise, the organization which integrates and manages individuals is what creates results and value.

It can be concluded that domestic enterprises lack competitive ability due to low productivity, non-existent or poorly implemented modern management tools and techniques, low quality, and low levels of new technology implementation. Domestic enterprises have to implement modern approaches and tools of management if they want to achieve and maintain competitiveness on the globalized market. Such an approach includes a wide application of knowledge-based methods and techniques which are aimed at quality and productivity. In addition, it is necessary to improve the technological and technical basis of domestic enterprises which involves the acquisition and application of newer generation manufacturing equipment. Fur future research it is recommended to address the influential factors that form the competitive ability of domestic enterprises.

ACKNOWLEDGEMENT

This work is a part of the current project TR-35017 funded by Ministry of Education, Science and Technological Development of the Republic of Serbia.

REFERENCES

- [1] Tiba S., Omri A., Literature survey on the relationships between energy, environment and economic growth, *Renewable and Sustainable Energy Reviews* Vol 69 2017, pp. 1129–1146. doi:10.1016/j.rser.2016.09.113.
- [2] The Global Competitiveness Report 2019, World Economic Forum, october 2019., str. ix, www.weforum.org
- [3] 2030: from technology optimism to technology realism, World Economic Forum, 20 january 2020, www.weforum.org
- [4] Gaspar J. dos S., Marques A. C., Fuinhas J. A., The traditional energy-growth nexus: A comparison between sustainable development and economic growth approaches, *Ecological Indicators* Vol 75 2017, pp. 286–296. doi:10.1016/j.ecolind.2016.12.048
- [5] Top risks are environmental, World Economic Forum, 15.01.2020., www.weforum.org
- [6] WEF spurs impact through stakeholder responsibility, World Economic Forum 27 january .2020. www.weforum.org
- [7] WEF spurs impact through stakeholder responsibility, World Economic Forum 27 january .2020. www.weforum.org
- [8] Bombiak E., Marciniuk-Kluska A., Green Human Resource Management as a Tool for the Sustainable Development of Enterprises: Polish Young Company Experience, *Sustainability* Vol 10 No 6 2018, pp. 1739. doi:10.3390/su10061739
- [9] Van Zanten J. A., van Tulder R., Multinational enterprises and the Sustainable Development Goals: An institutional approach to corporate engagement, *Journal of International Business Policy* 2018. doi:10.1057/s42214-018-0008-x
- [10] Kozlova E. P., Potashnik Y. S., Artemyeva M. V., Romanovskaya E. V., Andryashina N. S., Formation of an Effective Mechanism for Sustainable Development of Industrial Enterprises, *Growth Poles of the Global Economy: Emergence, Changes and Future Perspectives* 2019, pp. 545–556. doi:10.1007/978-3-030-15160-7_55.
- [11] The Davos Manifesto, WEF, 02 december 2019., www.weforum.org
- [12] Sauv  S., Bernard S., Sloan P., Environmental sciences, sustainable development and circular economy: Alternative concepts for trans-disciplinary research, *Environmental Development* Vol 17, 2016, pp. 48–56. doi:10.1016/j.envdev.2015.09.002
- [13] Markets can accelerate the transition to low-carbon economy, World Economic Forum, 29. january 2020., www.weforum.org.
- [14] H k T., Janoušková S., Moldan B., Sustainable Development Goals: A need for relevant indicators, *Ecological Indicators* Vol 60 2016, pp. 565–573. doi:10.1016/j.ecolind.2015.08.003
- [15] Chen M.-H., Kaufmann G., Employee Creativity and R&D: A Critical Review. *Creativity and Innovation Management* Vol 17 No 1 2008, pp. 71–76. doi:10.1111/j.1467-8691.2008.00471.x
- [16] The Global Competitiveness Report 2019, World Economic Forum, october 2019., str. 102, 174, 398, 434, 498., 514., www.weforum.org
- [17] Nikolić G., Petrović P., Poluskriveni ekonomski fenomeni, Arhipelag, Beograd, 2019. str. 31.
- [18] Pernick R., Wilder C., Revolucija čistih tehnologija, Kompjuter biblioteka, Beograd, 2008., str. 242.
- [19] Pernick R., Wilder C., Revolucija čistih tehnologija, Kompjuter biblioteka, Beograd, 2008., str. 283.

THE CRUCIAL ROLE OF INNOVATION IN ACHIEVING COMPETITIVENESS OF DOMESTIC ENTERPRISES

Dragan Čočkalović¹, Mihalj Bakator¹, Dejan Đorđević¹, Cariša Bešić², Sanja Stanisavljević¹

¹University of Novi Sad, Technical Faculty "Mihajlo Pupin", Đure Đakovića bb, Zrenjanin
23000, Republic of Serbia

²University of Kragujevac, Faculty of technical science in Čačak, Svetog Save 65,
Čačak 32000, Republic of Serbia
e-mail: dragan.cockalo@tfzr.rs

Abstract: Amidst the rapid globalization of markets, enterprises face challenges when it comes to achieving and maintaining competitive ability. The situation is even more complex and challenging for domestic enterprises which due to lack of productivity, quality, modern technologies and innovativeness. In this paper the competitiveness of domestic enterprises and the domestic economy are analysed. The main goal of the paper was to develop a theoretical model for improving the development and innovativeness of products and services. The model integrates key elements and influential factors which affect the innovativeness and development of products and services within an enterprise. Overall, the paper provides an adequate basis for future research in the domain of competitiveness and innovation.

Key words: innovation, competitiveness, domestic enterprises, globalization

INTRODUCTION

The globalization of markets has brought challenges for enterprises as they face changes in the relation dynamic between competitors. More precisely, globalization has increased and made international competition more pronounced. The fast advancement in information-communication technologies (ICTs) and other technologies as well resulted in the appearance of new industrial sectors. These technologies are the driving force of market globalization, as they increase productivity and quality. Further, with the widespread of advanced ICTs affects how enterprises conduct business on the international market [1]. Furthermore, the process of globalization as an economic, political, cultural, and technological integration of society affects international relations and national economies [2]. Positive or negative economic situations in one country easily can affect the economic situation of other countries [3]. Due to globalization enterprises have to improve productivity, quality and even innovativeness in order to achieve competitive ability [4]. In addition to dynamic, globalized markets, enterprises face challenges when it comes to conducting business within the framework of the fourth industrial revolution - Industry 4.0. Namely, in order to remain competitive, enterprises have to modern technologies which characterize Industry 4.0. [5]. Some of these modern technologies are RFID (Radio Frequency Identification), Big data analytics, cloud computing, wireless sensors, cyber security etc. [5]. The application of such technologies is almost an imperative for improving productivity, quality and innovativeness.

Now, when it comes to the competitiveness of domestic enterprises (micro-level), and national competitiveness (macro-level), globalization and modern technologies brought challenges which require effective measures which would improve the amount of value the enterprise gives to the customer for a certain price. The national competitiveness of Serbia is often handicapped due to old manufacturing equipment, high product and services prices, inadequate use of standards and new technologies, low productivity and lack of innovation [6]. The problem of low competitiveness of domestic enterprises is evident with national competitiveness. This further translates into lack of competitive ability on an international level. As noted before the main areas which need improvement are quality, productivity, modern management tools and techniques, and innovation.

Now, in this paper the crucial role of innovation in achieving and maintaining competitiveness on the globalized market is analysed. The main goal of the paper is to develop a theoretical model for improving the development of innovations. The model integrates external and internal influencing factors. In addition, the globalization of markets, the influence of Industry 4.0 and the domestic

economy competitiveness indicators are analysed. This way the whole paper has a solid base which focuses on supporting the main goal, which is the theoretical model. The paper consists of three main sections (excluding the *Introduction* and *Conclusion* sections). The first section discusses globalization, Industry 4.0 technologies and the challenges that it brings and competitive ability of enterprises as an imperative for survival on changing markets. In addition, the competitiveness of domestic enterprises and the domestic economy is analysed. Next, the model for improving the development of innovations is presented. The third section discusses guidelines regarding the improvement of innovation development and overall competitiveness.

GLOBALIZATION, INDUSTRY 4.0 AND COMPETITIVENESS

The globalization of markets has led to the development of horizontal competition where small and medium-sized enterprises (SMEs) are becoming the competition to big global corporations. This puts stress on SMEs as well as on corporations [7]. This further indicates that enterprises have to constantly improve several business metrics including quality, productivity, and innovativeness. The final aim of enterprises on globalized markets is to satisfy customers' needs and expectations [4]. Besides the necessity for adequate price strategy on the market and standardized product quality, enterprises have to conduct adequate innovations which will provide value for the customer [8]. It is evident that innovation is a crucial component for increasing value for the customer. Such increase in value can contribute to the retention of customers and also plays a role in developing customer loyalty.

Domestic enterprises amidst the globalization of markets are facing tremendous difficulties when it comes to achieving and maintaining competitive ability. The lack of competitiveness of domestic enterprises is mainly due to obsolete manufacturing equipment, low productivity, low quality and high maintenance costs [9]. This further indicates that domestic enterprises don't possess adequate innovative capacity which would increase the value of products and services that are distributed to the customers.

In addition to the challenges of globalized markets, enterprises also have to adapt their business activities and long-term strategies to the changes which brought by the fourth industrial revolution - Industry 4.0. SMEs can implement and apply modern information-communication technologies which would positively affect business performance [10]. However, without prior development of an effective strategy, there is a chance that implementing a modern ICT wouldn't result in with a proportionate increase in overall business performance. However, it is important to note that implementing ICT before a clear long-term strategy is formed, can cause employee resistance to the new technology, or lack of productivity and quality increase due to inadequate application of the new ICT [11]. From here, it can argued that domestic SMEs not only that need to improve productivity and quality, they also have to rationally implement, optimize and apply modern technologies, which will improve business activities in the long-term, and provide value to the customer. In addition, innovation has to be introduced in an effective way, in order "stand-out" from the competition. Therefore, it is evident that domestic SMEs in order to achieve competitive ability on the international market, they have to improve in several business aspects at once. However, is this achievable?

According to the Global Competitiveness Report 2019, Serbia is ranked 72nd out of 141 evaluated countries. The overall rank is based on other indicators including Institutions (75th); Infrastructure (51st); ICT adoption (77th); Macro-economic stability (64th); Health (76th); Skills (55th); Product market (73rd); Labour market (54th); Financial system (82nd); Market size (74th); Business dynamism (54th); and Innovation capability (59th) [12]. The lowest ranks are in the domain of the financial system, ICT adoption, institutions and health. These macro-indicators combined with the lack of modern manufacturing technologies, low productivity, and low quality on a micro-level (SMEs) it is clear why national competitiveness isn't ranked higher.

In Serbia, one of the major sources of investments into innovation are bank loans. Such loans are used for innovating existing products and services; innovating and implementing new procedures and methods with the goal to increase productivity, quality and to create value for the customer [13]. This kind of approach is promising as significant areas of required change when it comes to conducting business within the framework of Industry 4.0 include developing and applying management models, increased need for improving skills and knowledge, improving ethical and moral principles of

conducting business, an improving innovation of products and productivity [14]. Now, some of the important problems of the domestic economy in relation to competitiveness are presented in Table 1.

Table 1. Most pronounced problems of the domestic economy regarding competitiveness in 2019

#	Indicator	World rank
1.	Sophistication of customers	124
2.	Ability to rely on professional management	114
3.	Relationship towards entrepreneurship	107
4.	Protection of private property	106
6.	Legal system efficiency	94
8.	Independent Judiciary	101
9.	Market dominance level	110
10.	Protection of Intellectual Property	104
11.	Cooperation between employers and employees	107

Source: [12]

From the data in Table 1., it is evident that the Serbian business environment lacks adequate strength in several crucial domains (Indicators). Sophistication of customers and the ability to rely on professional management as lowest ranked indicators indicate the situation on the market and as well as why the relationship towards entrepreneurship is inadequate. Furthermore, Serbia lags behind when it comes to innovativeness and modern technology application, and the majority of domestic enterprises conduct business with outdated manufacturing equipment [1].

In summary, based on the above noted studies and presented data, it is evident that domestic enterprises and further the whole domestic economy lacks competitive ability due to low productivity, low quality, practically non-existent innovations and overall low application of modern ICTs. SMEs are unable to achieve and maintain a competitive position on the international market as key indicators are not balanced on a national scale.

MODEL FOR IMPROVING THE DEVELOPMENT OF INOVATIONS

Based on the conducted literature and data analysis a model for improving the development and innovativeness of products within an enterprise, is developed. The model integrates several elements, which function together with the goal of improving the development and innovativeness of products.

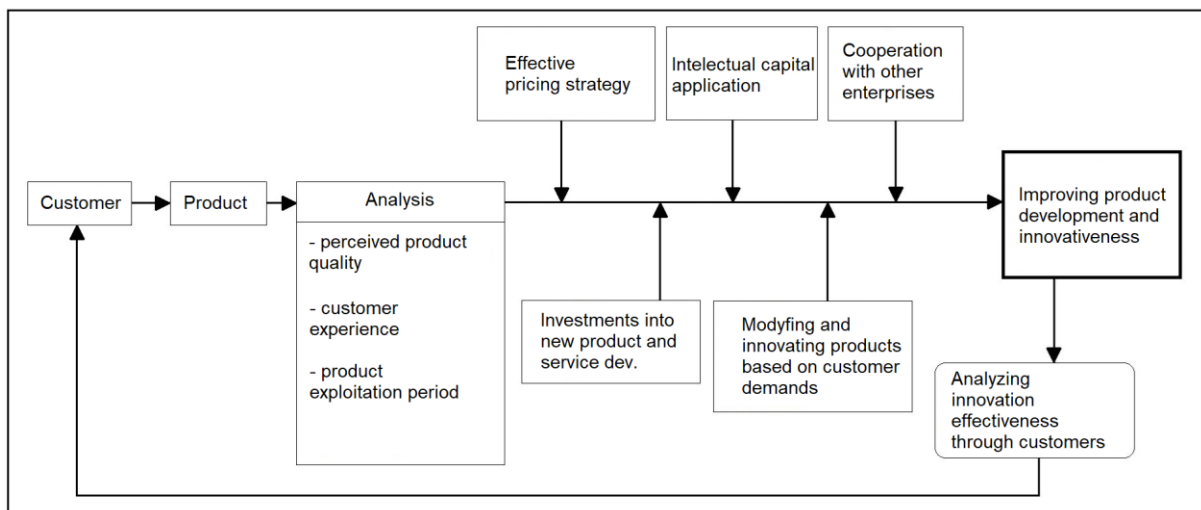

Fig 1. Model for improving the development and innovativeness of products

The development and innovativeness of products are crucial factors when it comes to business performance and achieving competitive ability on the market. The model presented on Figure 1. includes activities which are aimed at improving the development and innovativeness of products. The

improvement process is conducted through customer evaluation. Perceived product quality, customer experience and the product exploitation period are analysed in order to create a reference point for implementing improvements. The main activities of improving the development and innovativeness of products include:

- effective pricing strategy,
- the application of intellectual capital,
- cooperation with other enterprises,
- investments into the development of new products and services,
- modifying and innovating products based on customer demands.

As noted earlier, the importance of product innovativeness and development lies in its “power” to shift competitive advantage on the market. This further indicates, that on globalized markets, in order to achieve and maintain competitiveness on the market, enterprises have to evaluate innovativeness as part of their long-term competitiveness strategy.

GUIDELINES AND SUGGESTIONS FOR IMPROVEMENT

Domestic enterprises are known to lack competitive advantage on the international market. Large set of factors, including quality, innovativeness, productivity, manufacturing technology and others, represent the main issues of conducting business within a domestic enterprise. Based on the reviewed literature, and the developed model, the following guidelines for improving product development and innovativeness are proposed:

- enterprises have to invest into new products and services which bring value to the customer;
- customer experience has to be taken into consideration when new products and services are being developed;
- in the process of developing and innovating products and services it is necessary to apply intellectual capital as well as to cooperate with other enterprises;
- enterprises have to develop effective pricing strategies through which an adequate market share could be achieved.

Delivering value to the customer is an imperative for developing customer loyalty. Products and services have to contain value which arises during the exploitation period of the product or service. In the modern business world, customers expect to be satisfied with a product or service, and they will appreciate if their needs and expectations are met in the form of customer retention, and later on, customer loyalty. Further, when an enterprise invests into developing or innovating a product a service, it is necessary to obtain customer data on their experience with previous products, future expectations, needs, wishes and other metrics. Obtaining, processing and analysing this data is an important part in the innovation process and development process. Namely, without proper feedback from customers, development and innovation may not bring adequate results, as they would directly address customer expectations. From here, it is evident that enterprises have to rely on intellectual capital. Developing and innovating products and services, which are aligned with customer expectations and needs, requires the application of expertise and skills of employees. Finally, in order to make their products and services competitive, besides innovativeness and good quality, an adequate pricing model and long-term strategy has to be put in place. The strategy has to be flexible in order to adapt to dynamic changes on the market.

CONCLUSION

Innovation, productivity, quality, and value represent the main factors which heavily affect business performance of domestic enterprises. In addition, domestic enterprises should focus on creating conditions which are adequate for a wider application of modern technologies. As noted previously, effective strategies which include pricing, innovation and quality are an imperative for achieving and

maintaining a competitive edge on the market. It can be concluded that the globalization of markets has put a tremendous amount of pressure on domestic enterprises, and customer satisfaction should be achieved through developing and innovating products and services which are based on customer feedback. Adequate application of customer feedback requires modern ICTs, through the data is obtained, processed and analysed.

The main limitation of this paper is the lack of a survey study conducted in domestic enterprises. In addition, a meta-analysis approach would also provide a more in-depth analysis. Now, this paper managed to concisely present the literature behind competitive ability and improving innovativeness and development of new products. Additionally, a theoretical model was developed. For future research it is recommended to address the innovativeness of domestic enterprises and its correlation with business performance and overall competitiveness on the market. Further, data from similar studies should be noted and compared where possible. This approach would further provide insight into the significance and complexity of competitive ability and other mechanisms which affect it.

ACKNOWLEDGEMENT

This work is a part of the current project TR-35017 funded by Ministry of Education, Science and Technological Development of the Republic of Serbia.

REFERENCE

- [1] Čočkalović, D., Đorđević, D., Bogetić, S., Bakator, M., Bešić, C., Competitiveness of Domestic Enterprises in Changing Markets and Industry 4.0, Proceedings of the 4th International Conference on the Industry 4.0, 5-7th June 2019, Springer Nature, Switzerland, pp. 113-127. doi: 10.1007/978-3-030-18180-2_9.
- [2] Bešić, C., Đorđević, D., Menadžment znanja, Fakultet tehničkih nauka: Čačak, 2017, str. 25.
- [3] Ritzer, G., Dean, P., Globalization - The Essentials, John Wiley & Sons: Hoboken, New Jersey 2019, str. 100.
- [4] McMillan, M., Rodrik, D., Verduzco-Gallo, I., Globalization, Structural Change and Productivity Growth, with an Update on Africa, World Development, Vol 63 2014, pp. 11-32. doi:10.3386/w17143
- [5] Xu, L.D., Xu, E. L., Li, L., Industry 4.0: state of the art and future trends, International Journal of Production Research, Vol 56 No 8 2018, pp. 2941–2962. doi:10.1080/00207543.2018.1444806
- [6] Arsić M., Dugoročne posledice ekonomskog sloma privrede Srbije tokom 90-ih godina 20-og veka, Ekonomske ideje i praksa, Vol 22 2016, str. 25-41.
- [7] Latif, Z., Mengke, Y., Danish Latif, S., Ximei, L., Pathan, Z. H., Jianqiu, Z., The dynamics of ICT, foreign direct investment, globalization and economic growth: Panel estimation robust to heterogeneity and cross-sectional dependence, Telematics and Informatics, Vol 35 No 2 2018, pp. 318–328. doi:10.1016/j.tele.2017.12.006
- [8] A prediction for globalization in 2018, WEF 2018., www.weforum.org.
- [9] Kovačević, M., Uzroci deindustrijalizacije i ograničenja za reindustrijalizaciju. U knjizi Deindustrijalizacija u Srbiji - Mogućnosti revitalizacije industrijskog sektora, Beograd: Institut ekonomskih nauka 2014, str. 11-44.
- [10] Mittal, S., Khan, M. A., Romero, D., Wuest, T., A critical review of smart manufacturing & Industry 4.0 maturity models: Implications for small and medium-sized enterprises (SMEs), Journal of Manufacturing Systems, Vol 49 2018, pp. 194–214. doi:10.1016/j.jmsy.2018.10.005
- [11] Moeuf, A., Pellerin, R., Lamouri, S., Tamayo-Giraldo, S., Barbaray, R., The industrial management of SMEs in the era of Industry 4.0, International Journal of Production Research, Vol 56 No 3 2017, pp. 1118–1136. doi:10.1080/00207543.2017.1372647
- [12] World Economic Forum (WEF). The Global Competitiveness Report 2019. Available at: http://www3.weforum.org/docs/WEF_TheGlobalCompetitivenessReport2019.pdf (Accessed on 13th April 2020)

- [13] Zakic, N., Popovic, J., Miskic, M., The Linkages Between Investments in Innovation and Business Performance in Serbia, *Management: Journal Of Sustainable Business And Management Solutions In Emerging Economies* 2019. doi:10.7595/management.fon.2019.0017
- [14] Reif, R.L., *Industrial revolution* (2018). <https://www.weforum.org/agenda/2018/01/thefourth-industrial-revolution-a-survival-guide/>. Accessed Jan 2018

EMPLOYEES' PERCEPTION OF ENERGY CONSUMPTION AND ENVIRONMENTAL PROTECTION

Ivana Dolga¹, Ladin Gostimirović², Aleksandra Mihailović^{1*}, Nebojša M. Ralević¹

¹University of Novi Sad, Faculty of Technical Sciences, Novi Sad, Serbia

²Visoka poslovnotehnička škola, Doboј, Bosnia and Herzegovina, Republic of Srpska

e-mail: zandra@uns.ac.rs

Abstract: Energy consumption represents a significant part of the total costs for companies, with the dominant usage of electrical energy. The study is based on the attitudes of the employees of companies towards energy consumption and it involves raising awareness regarding the usage of alternative energy sources in order to reduce environmental pollution. The analysis has been performed considering the EU standards, since the Republic of Srpska is an official candidate to enter the European Union. The survey examined employee attitudes and perceptions of other sources of energy, as well as energy from renewable sources of energy as a supplement and replacement for electrical energy. The conducted study involved 150 respondents (employees) from different companies and their opinions in the field of energy, especially about the use of alternative energy sources. This paper demonstrates the relationship between a company (employees) with a higher energy cost and a level of awareness of different sources of energy.

Key words: employee, energy consumption, environmental attitudes

INTRODUCTION

The paper is derived on the statistical concluding based on some attitudes of the respondents who participated in previous surveys conducted in Republic of Serbia and Republic of Srpska. The survey "Renewable Energy Sources" was conducted on a sample of 150 respondents. The survey consisted of questions about personal data and opinion on efficient consumption and renewable energy sources (1. Competitiveness and consumer energy, 2. Energy sources). Each of the questions asked consisted of a response with a scale of 5 offered responses: A - insignificant, B - less significant, C - medium, D - very significant, E - extremely important.

We will consider the criterion question:

Electricity consumption has a significant share in the total cost of the company.

The answer to this criterion question provides insight into respondent attitude on the matter of electricity consumption within his company. Depending on the answer to the given criterion question, the entire sample is split into 5 groups:

A - Insignificant (0 respondents), B - less significant (4 subjects), C - intermediate (36 subjects), D - very significant (69 respondents) and E - extremely significant (41 subjects).

Based on the distribution of the answers to the criterion question, we excluded the group A from the future consideration, since there were no respondents.

The answer to this criterion question shows us how the respondent looks at the consumption of electricity within the work he deals with. Since this is the criterion question, it means that the entire sample is divided into 4 groups depending on their answers.

METHODOLOGY

Our goal is to determine whether there are differences and on which questions differences exist between the 4 groups mentioned. That is, among the respondents who consider that electricity consumption has a significant share in the total costs of the company. We will test hypotheses:

H1– Groups defined by criteria question (CQ) have different opinion (answer) on the question "I consider doing business in accordance with environmental principles and replacing energy sources that are problematic from an environmental point of view. (ECOLOGY)"-(Q1)

H2 - Groups defined by criteria question have different opinion (answer) on the question “The economy significantly affects the increase in the amount of greenhouse gases in the atmosphere. (CO2)”-(Q2)

H3 - Groups defined by criteria question have different opinion (answer) on the question “The use of alternative energy sources reduces environmental pollution. (ALTERNATIVE SOURCES)”-(Q3)

H4 - Groups defined by criteria question have different opinion (answer) on the question “I think that knowledge in the field of energy is important. (KNOWLEDGE)”-(Q4)

In this study, MANOVA and ANOVA analysis was performed. The analysis was done with R-project. First, the MANOVA analysis was done where we tested whether there was a difference on all groups. If there is the difference as a result of MANOVA, later ANOVA analysis was conducted to test between which groups differences exists.

RESULTS

Test MANOVA is testing if there is a difference between criteria question and other group of questions:

Groups defined by criteria question (CQ) have different opinion (answer) on the group of question Q1, Q2, Q3 and Q4.

Table 1. Test MANOVA results are shown in the table bellow

	Df	numDf	den Df	F value	Pr (>F)
CQ	3	12	435	2.9324	0.000622 ***
Residuals	146				

Significant codes: 0 ‘***’ 0.001 ‘**’ 0.01 ‘*’ 0.05 ‘.’ 0.1 ‘ ’ 1

Test MANOVA shows that is statistically significant difference, between some groups. ANOVA results will show if there is significant difference for each question. With further analysis the difference will be more precise detected.

First test was done on the first question in relation to the criterion question:

1. Groups defined by criteria question (CQ) have different opinion (answer) on the question “I consider doing business in accordance with environmental principles and replacing energy sources that are problematic from an environmental point of view. (ECOLOGY)”
2. Electricity consumption has a significant share in the total cost of the company. (criterion question, CQ)

Table 2. ANOVA analysis for criteria question comparing to Q1

	Df	Sum Sq	Mean Sq	F value	Pr (>F)
CQ	3	12	435	5.083	0.00224 **
Residuals	146				

Significant codes: 0 ‘***’ 0.001 ‘**’ 0.01 ‘*’ 0.05 ‘.’ 0.1 ‘ ’ 1

The test shows that is statistically significant difference, between some groups, so hypothesis H1 is proven.

Analysis of each group of answers on criteria question comparing to Q1

Groups defined by criteria question	Diff	lwr	upr	p adj
less significant- extremely significant	-1.79878049	-3.0156165	-0.5819445	0.0010334
intermediate significant – extremely significant	-0.29878049	-0.8293593	0.2317983	0.4622172
very significant - extremely significant	-0.20820078	-0.6662663	0.2498647	0.6396444
intermediate significant - less significant	1.50000000	0.2756757	2.7243243	0.0095115
very significant - less significant	1.59057971	0.3958915	2.7852680	0.0039115
very significant - intermediate significant	0.09057971	-0.3870228	0.5681822	0.9605701

There was a significant difference between the groups (less significant- extremely significant) with $p = 0.0010334$, (intermediate significant - less significant) with $p = 0.0095115$ and (very significant - less significant) with $p = 0.0039115$. The result is not representative because the group less significant is very small.

Answers distribution for criteria question comparing to Q1

	A	A%	B	B%	C	C%	D	D%	E	E%
extremely significant	1	2.44	2	4.88	3	7.32	23	56.10	12	29.27
less significant	2	50.00	0	0.00	1	25.00	1	25.00	0	0.00
intermediate significant	0	0.00	3	8.33	10	27.78	16	44.44	7	19.44
very significant	1	1.82	3	5.45	17	30.91	33	60.00	1	1.82

Second test was done on the first question in relation to the criterion question:

1. Groups defined by criteria question (CQ) have different opinion (answer) on the question “The economy significantly affects the increase in the amount of greenhouse gases in the atmosphere. (CO₂)”
2. Electricity consumption has a significant share in the total cost of the company. (criterion question, CQ)

Table 3. ANOVA analysis for criteria question comparing to Q2

	Df	Sum Sq	Mean Sq	F value	Pr (>F)
CQ	3	9.77	3.257	4.838	0.00307 **
Residuals	146	98.29	0.673		

Signif. codes: 0 ‘***’ 0.001 ‘**’ 0.01 ‘*’ 0.05 ‘.’ 0.1 ‘ ’ 1

The test shows that is statistically significant difference, between some groups, so hypothesis H2 is proven.

Analysis of each group of answers on criteria question comparing to Q2

Groups defined by criteria question	Diff	lwr	Upr	p adj
less significant- extremely significant	-0.2378049	-1.3547798	0.87917003	0.9455229
intermediate significant – extremely significant	-0.7100271	-1.1970633	-0.22299087	0.0012517
very significant - extremely significant	-0.3718628	-0.7923367	0.04861097	0.1031029
intermediate significant - less	-0.4722222	-1.5960709	0.65162645	0.6949836

significant				
very significant - less significant	-0.1340580	-1.2307027	0.96258681	0.9888607
very significant - intermediate significant	0.3381643	-0.1002432	0.77657172	0.1910037

There was a significant difference between the groups (intermediate significant – extremely significant) with $p = 0.0012517$.

Answers distribution for criteria question comparing to Q2

	A	A%	B	B%	C	C%	D	D%	E	E%
extremely significant	0	0.00	0	0.00	4	9.76	13	31.71	24	58.54
less significant	0	0.00	0	0.00	1	25.00	1	25.00	2	50.00
intermediate significant	0	0.00	3	8.33	10	27.78	15	41.67	8	22.22
very significant	0	0.00	3	4.35	12	17.39	28	40.58	26	37.68

Third test was done on the first question in relation to the criterion question:

- Groups defined by criteria question (CQ) have different opinion (answer) on the question “The use of alternative energy sources reduces environmental pollution. (ALTERNATIVE SOURCES)”
- Electricity consumption has a significant share in the total cost of the company. (criterion question, CQ)

Table 4. ANOVA analysis for criteria question comparing to Q3

	Df	Sum Sq	Mean Sq	F value	Pr (>F)
CQ	3	7.93	2.6427	2.781	0.0432 *
Residuals	146	138.75	0.9503		

Signif. codes: 0 ‘***’ 0.001 ‘**’ 0.01 ‘*’ 0.05 ‘.’ 0.1 ‘ ’ 1

The test shows that is statistically significant difference, between some groups, so hypothesis H3 is proven.

Analysis of each group of answers on criteria question comparing to Q3

Groups defined by criteria question	Diff	Lwr	Upr	p adj
less significant- extremely significant	-0.56707317	-1.8941646	0.76001828	0.6836563
intermediate significant – extremely significant	-0.62262873	-1.2012824	-0.04397507	0.0295948
very significant - extremely significant	-0.23011665	-0.7923367	0.26945339	0.6296487
intermediate significant - less significant	-0.05555556	-1.3908138	1.27970269	0.9995456
very significant - less significant	0.33695652	-0.9659804	1.63989349	0.9074782
very significant - intermediate significant	0.39251208	-0.1283652	0.91338931	0.2086749

There was a significant difference between the groups (intermediate significant – extremely significant) with $p = 0.0295948$.

Answers distribution for criteria question comparing to Q3

	A	A%	B	B%	C	C%	D	D%	E	E%
extremely significant	0	0.00	1	2.44	8	19.51	9	21.95	23	56.10
less significant	0	0.00	0	0.00	2	50.00	1	25.00	1	25.00
intermediate significant	2	4.44	1	2.22	13	28.89	10	22.22	19	42.22
very significant	1	1.45	2	2.90	17	24.64	19	27.54	30	43.48

Fourth test was done on the first question in relation to the criterion question:

1. Groups defined by criteria question (CQ) have different opinion (answer) on the question "The use of alternative energy sources reduces environmental pollution. (ALTERNATIVE SOURCES)"
2. Electricity consumption has a significant share in the total cost of the company. (criterion question, CQ)

Table 5.ANOVA analysis for criteria question comparing to Q4

	Df	Sum Sq	Mean Sq	F value	Pr (>F)
CQ	3	10.98	3.660	3.019	0.0318 *
Residuals	146	176.99	1.212		

Signif.codes: 0 '***' 0.001 '**' 0.01 '*' 0.05 '.' 0.1 ' ' 1

The test shows that is statistically significant difference, between some groups, so hypothesis H4 is proven.

Analysis of each group of answers on criteria question comparing to Q4

Groups defined by criteria question	Diff	Lwr	Upr	p adj
less significant- extremely significant	-1.6951220	-3.19401917	-0.1962247	0.0197987
intermediate significant – extremely significant	-0.3062331	-0.95979944	0.3473333	0.6166306
very significant - extremely significant	-0.1951220	-0.75936652	0.3691226	0.8055053
intermediate significant - less significant	1.3888889	-0.11923240	2.8970102	0.0828356
very significant - less significant	1.5000000	0.02838431	2.9716157	0.0439255
very significant - intermediate significant	0.1111111	-0.47719908	0.6994213	0.9610314

There was a significant difference between the groups (less significant- extremely significant) with $p = 0.0197987$ and (very significant - less significant) with $p = 0.0439255$. The result is not representative because the group less significant is very small.

Answers distribution for criteria question comparing to Q4

	A	A%	B	B%	C	C%	D	D%	E	E%
extremely significant	1	2.44	5	12.20	3	7.32	8	19.51	24	58.54
less significant	2	50.00	0	0.00	1	25.00	0	0.00	1	25.00
intermediate significant	1	2.78	3	8.33	9	25.00	9	25.00	14	38.89
very significant	2	2.90	3	4.35	13	18.84	26	37.68	25	36.23

DISCUSSION

Based on the results, we can conclude:

- Respondents on CQ with answers (intermediate significant - extremely significant) are significantly different in responds on the following question “The economy significantly affects the increase in the amount of greenhouse gases in the atmosphere. (CO2)”
- Respondents on CQ with answers (intermediate significant – extremely significant) are significantly different in responds on the following question “The use of alternative energy sources reduces environmental pollution. (ALTERNATIVE SOURCES)”

CONCLUSION

1. For hypothesis H2, H3 results indicated that there is significant differences between criteria groups with analyses MANOVA and ANOVA.
2. For hypothesis H1 and H4 we get different results with MANOVA and ANOVA analysis, but the difference is in the respective group “less significant”, that group has a small number of answers, so the result is not representative

ACKNOWLEDGEMENTS

The authors acknowledge the financial support of the Ministry of Education, Science and Technological Development of the Republic of Serbia, within the project No. 451-03-68/2020-14/200156: “Innovative scientific and artistic research from the FTS (activity) domain”.

REFERENCES

- [1] Balat, M., An Overview of Biofuels and Policies in the European Union, Energy Sources, Part B: Economics, Planning, and Policy, No.2, pp.67 – 181, 2007.
- [2] Best, G., Alternative energy crops for agricultural machinery biofuels – focus on biodiesel, Agricultural Engineering International: the CIGR E-journal, Vol. 8, 2006.
- [3] Brkić, M., Skala, D., Mulić, R., Marić, M., Technology production of biodiesel - Biodiesel and ecological alternative to liquid fuel, Contemporary Agricultural Engineering, Vol.30, pp.73-105, 2005.
- [4] Ivana Dolga, Vladimir Dj. Djaković, LadinGostimirović, Nebojša M. Ralević, Analysis Of Awareness Of Electrical Energy Consumption In Companies And Households, The 25th International Symposium on Analytical and Environmental Problems, October 7-8, 2019, SZAB, University of Szeged, Department of Inorganic and Analytical Chemistry, H-6720 Szeged, Dugonicstér 13, Hungary, pp. 302-306, 2019/
- [5] LadinGostimirović, AleksandarKršić, Aleksandra Mihailović, Nebojša M. Ralević, Attitudes Towards Energy Consumption From The Perspective Of Employees In Republic Of Srpska, 145-150, IX International Conference Industrial Engineering and Environmental Protection 2019 (IIZS 2019) October 3rd-4th, 2019, Zrenjanin, Serbia
- [6] Martin Kaltschmitt, Wolfgang Streicher, Andreas Wiese (ed): Renewable energy. Technology, economics and environment, Springer, Berlin/Heidelberg. 2007.

- [7] Nebojša M. Ralević, Ivana Dolga, Aleksandra Mihailović, Vladimir Dj. Djaković, Goran B. Andjelić, Analysis of Employee's Awareness of Energy Costs, The 24th International Symposium on Analytical and Environmental Problems, October 8-9, 2018, SZAB, University of Szeged, Department of Inorganic and Analytical Chemistry, H-6720 Szeged, Dóm tér 7, Hungary, pp. 383-387, 2018.
- [8] Vanja Vukoslavčević, Ladin Gostimirović, Aleksandra Mihailović, Ljubo Nedović, Nebojša M. Ralević, Attitudes Towards Energy Consumption: Employee Perspective, 345-350, VIII International Conference Industrial Engineering and Environmental Protection 2018 (IIZS 2018) October 11-12th, 2018, Zrenjanin, Serbia, Technical faculty "Mihajlo Pupin", Zrenjanin, Serbia

LANDSCAPE CHANGE SURVEY IN THE GÖDÖLLŐ HILLS BASED ON HISTORICAL MAPS

Krisztina Demény¹

¹Óbuda University, Rejtő Sándor Faculty of Light industry and Environmental Protection Engineering, Institute of Environmental Engineering and Natural Science, Budapest, Hungary
e-mail: demeny.krisztina@rkk.uni-obuda.hu

Abstract: In Hungary, economic and social transformation after the political changeover played a major role in the evolution of the rapidly changing structure of the landscape. In order to reconstruct the earlier conditions, we need to familiarise ourselves with the history of the landscape. As the quality of the landscape has been deteriorating at a growing pace, we also need to examine the main parameters of the landscape components. Moreover, we need to devote special attention to the areas most sensitive from the perspective of nature conservation (e.g. the situation of wetlands and forest lands) to be able to monitor their alteration and mitigate the anthropogenic impact if possible. The main objective of this research work was focused on surveying earlier conditions of landscape by historical maps.

Key words: land use, land use change, historical maps.

INTRODUCTION

The area that my research has focused on is the Gödöllő Hills, a micro-region situated near the capital, in the metropolitan belt of the city. The proximity of the capital is both an advantage and a drawback for the Hills. Thanks to the favorable traffic system and its geographical situation, its population has been steadily growing. The development of the area has been determined not only by population growth, but also by industrial suburbanization [1, 2, 3].

However, all of the above may turn into a disadvantage: the growing number of inhabitants entails a heightened burden on the environment, one of the biggest stress factors for the region. Despite the trends of suburbanization, society has a growing need for a natural, “intact” environment, and ironically, in some cases, this desire seems to be the very motif of suburbanization. This is why research monitoring changes in landscape use is so important – research that simultaneously examines the extent of degradation and stability of the landscape. Regarding their physical geography, the Gödöllő Hills constitute an area of geomorphological transition, but due to their natural and landscape values their preservation is a key priority. Another reason why the specification of natural and quasi-natural areas is a quintessential task is that there are more and more factors leading to or projecting changes in this area.

The primary analysis of research findings concerning the presentation of changes in the landscape and in land cover is based on the examination of historical maps [4, 5, 6, 7, 8, 9, 10, 11], aerial photography [12, 13, 14, 15], as well as (GIS based) satellite images [16, 17, 18, 19]. The advantage of such approaches is that they make it possible to understand current events and to explore future possibilities. They can provide a basis for exploring the differences and similarities or the stability and changes between two or more points in time, even in terms of land use categories. They may also help to resolve disputed land ownership issues. This study applies the latter direction, i.e. out of the different approaches; I have chosen the method that utilizes historical maps.

MATERIAL AND METHODS

Location of the area under examination

According to the micro-region typology of Marosi & Somogyi (1990), as well as Dövényi (2010), the Gödöllő Hills are part of the macro-region called North Hungarian Mountains. Within that, they are located in the northern part of the group of micro-regions called Gödöllő–Monor Hills in the meso-region of the Cserhát. The Gödöllő Hills (stretching over 550 km²) are situated between 130 and 344 m above sea level, and gradually become lower towards the southeast [20]. Their location, geological

and climatic conditions make them a transitory zone between the North Hungarian Mountains and the Great Hungarian Plain. Their independent hills are wedged between the latter two macro-regions.

Land cover survey

I examined the changes in the landscape use of the Gödöllő Hills on the basis of literary sources and military survey maps (I-III, 1763–1885) in order to identify the earlier structure of the landscape. Using GIS tools and the ArcView 3.2 software, I digitalized the maps, identified the typical land use types, and prepared a comparative analysis between adjacent survey dates, displaying my findings on a map. I used Microsoft Excel to prepare a mathematical statistical analysis: I calculated the distribution of the individual land use types and expressed the difference between the various periods in percentage.

I prepared the area of land cover maps using the following sources:

1. 1st (1763–1787) Military Survey Map (Scale = 1:28,800) (Arcanum Ltd.),
2. 2nd (1806–1869) Military Survey Map (Scale = 1:28,800) (Arcanum Ltd.),
3. 3rd (1869–1885) Military Survey Map (Scale = 1:25,000) (Arcanum Ltd.).

I distinguished seven typical land use forms: built-up/residential areas (artificial surfaces: built-up areas, farm buildings and industrial buildings, traffic routes); forests (scrublands and bushes); wetlands (surface waters, reedy marshlands); meadows and pastures; hobby plots and orchards; and vineyards.

RESULTS AND DISCUSSION

At the end of the 1700s, at the time of the First Military Survey, the area examined was sparsely populated: the ratio of built-up/residential areas was a mere 0.62% (Table 1.). After the 150-year Ottoman occupation, nearly half of the settlements of the Gödöllő Hills were registered as uninhabited and abandoned. At the same time, Szada, Veresegyház, Mogyoród, Gödöllő, Pécel, Valkó and Úri emerged from the Ottoman rule as inhabited settlements. The population of the settlements began to rise again at the beginning of the 1700s [21]. In this period, the main land use form was meadow and pasture management, which was important for animal husbandry. Apart from that, forest lands also played a significant role: there were extensive and contiguous forests in the eastern part of the Hills (forests of Gödöllő and Isaszeg).

Table 1. Evolution of different land use types in Gödöllő Hills based on 1st Military Survey Map (1763-1787)

Land use type	Area (ha)	Area (%)
Built up area	312,81	0,62
Forest	19476,80	38,90
Wetland	3270,04	6,53
Pasture, meadow	23964,93	47,86
Arable land	1160,35	2,32
Orchard	343,96	0,69
Vineyard	1541,01	3,08

Between the First (1763–1787) and Second (1806–1869) Military Surveys, the most remarkable change took place in the proportion of arable lands (it rose from 2.32% to 19.97%) (Fig. 1). Grasslands were broken especially in the northern and southern parts of the area, most likely parallel to the population increase. The breaking of the grasslands led to the decline of animal husbandry. There was a negative change in the proportion of forest lands: by the mid-1800s, their ratio dropped from 39% to 32%. It was especially between Gödöllő, Isaszeg and Pécel that forests were cut down, for instance, at the site of the Battle of Isaszeg. There were efforts of reforestation as well, especially

to capture the sand and to line roads and estates with trees [21]. No significant change occurred regarding vineyards and orchards. Nearly all of the settlements of the micro-region had their own vineyards, which were considered to be the main source of livelihood in many places.

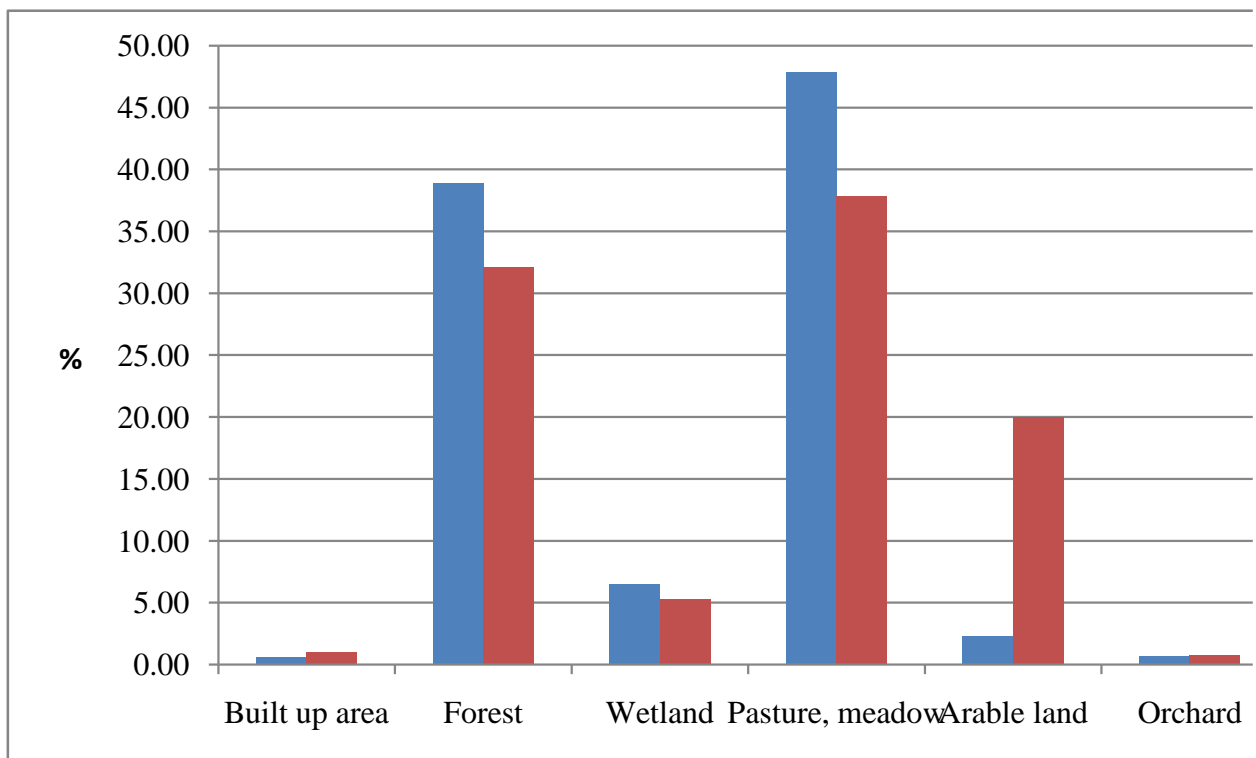

Fig. 1. Land use change in Gödöllő Hills between 1st (1763-1787) and 2nd Military Survey map (1852-1869)

By the end of the 1800s, the most characteristic land use form was the cultivation of the arable lands, which accounted for nearly half of the area examined (46.6%) (Fig.2.).

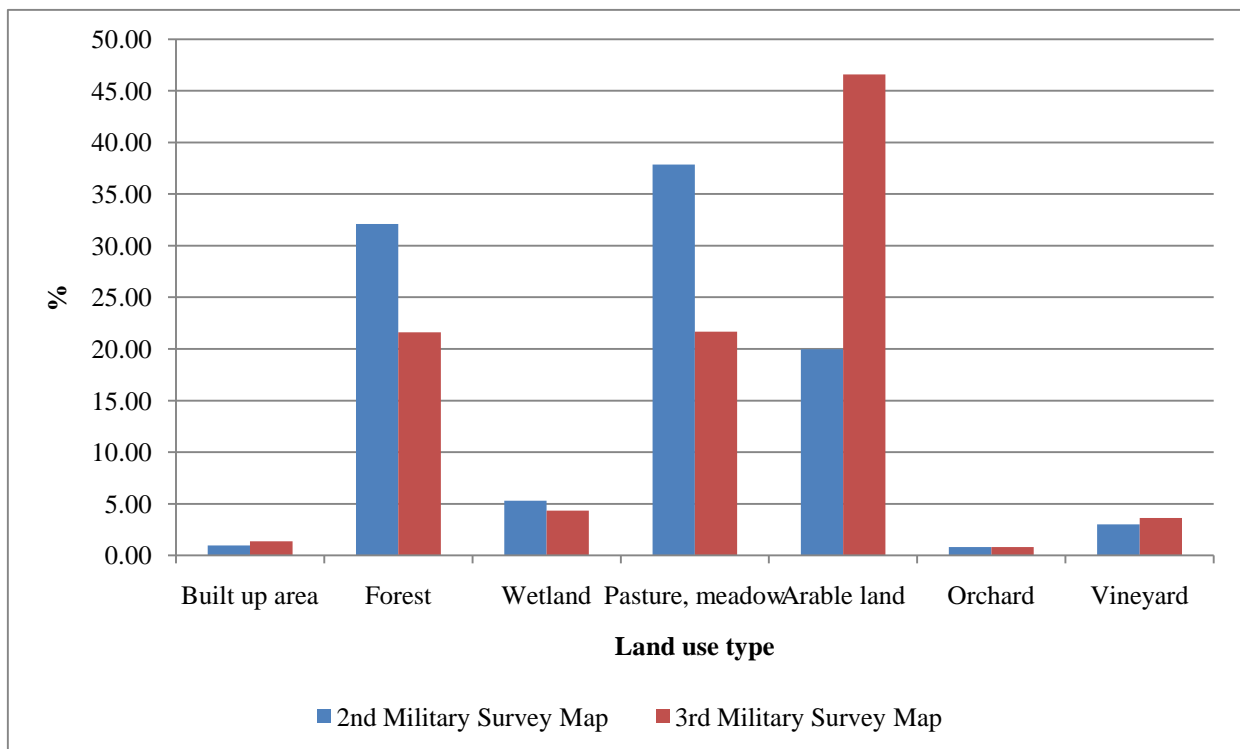

Fig. 2. Land use change in Gödöllő Hills between 2nd (1852-1869) and 3rd Military Survey map (1872-1885)

The trends described above continued in this period as well. The proportion of meadows, pastures and forest lands decreased, and grasslands continued to be broken for farming. Deforestation was also pursued. It was mostly the forests of Gödöllő and Isaszeg that were cut down, and the previously extensive forests became fragmented. This is clearly indicated by the number of polygons of the forest lands. There were 142 polygons on the map of the Second Military Survey versus 329 on the third military map. There were minor changes in the other land use forms; viticulture and fruit production continued to have a decisive role in the life of the settlements.

CONCLUSION

Based on the historical (military) maps, it can be affirmed that significant changes have taken place, especially with respect to society's landscape-forming effect. This claim is also supported by Frisnyák's (2008) [22] research (about the 18th–19th centuries in the Gödöllő Hills), who said that subsequent generations have created a cultural landscape in these hills.

There are three categories that can be distinguished according to the changing trends. The first category includes land use forms where we can see a clear increase, such as in the case of built-up areas: at the end of the 18th century, urban development was 0.62%, which leaped to 15.11% by the end of the 20th century. Growth was permanent, with no setbacks in any of the periods. The settlements of this micro-region began to be repopulated at the beginning of the 1700s. The economic development and repopulation of the area was greatly enhanced – in addition to the returning inhabitants – by the Slovaks coming from Upper Hungary [22]. At the time of the “new beginning”, there were only a couple of hundreds of people living in a settlement, whereas these towns – especially the ones in the metropolitan belt of the capital – have tens of thousands of inhabitants today. Over the past two centuries, essentially, the number of settlements has not changed. These towns have been constantly around, with a few minor exceptions (certain names have been modified, settlements have been consolidated, or parts of a settlement have become independent). The growth in the number of inhabitants also affects certain aspects of nature conservation as the latter is closely interrelated with the expansion of settlement and traffic infrastructure (construction of real estate, public buildings, industrial areas, railway lines and motorways). This further reinforces anthropogenic influence, and

consequently leads to the reduction and fragmentation of undisturbed natural areas, diminishing the quality of the remaining areas.

The second category contains wetlands, meadows and pastures, and vineyards. These land use forms were characterized by a steady decrease due to the growing need for land (parallel to the trends described above). With the exception of vineyards, this led to a reduction in the size of lands that would have been potentially valuable from the perspective of nature conservation. The shrinking of the size of lands covered by water is a phenomenon whose relevance is not restricted to the territory of the Gödöllő Hills – it is typical of other areas in Hungary as well [23, 24]. The increasing importance of agriculture and settlements has played a major role in that.

The third category includes those land use forms where there were changing, yet opposite trends in the period examined, in the case of forests and arable lands. The forest lands of Hungary – and of the Gödöllő Hills – have become larger over the past 90 years [25]. However, there is a significant difference between the proportions of forest cover in the country and in this micro-region: the forest cover of the Gödöllő Hills is nearly twice as high (approx. 21%) as the national average and is nearly 10% higher than the average of the North Hungarian Mountains [25, 26].

By now, vineyards represent the smallest land ratio, having decreased from 3.08% at the end of the 18th century to 0.44%. The history of this micro-region used to be hallmarked by the wine-growing sector. Up until the end of the 19th century, some settlements even used to make their own wine (Galgóczy 1877b). The expansion of orchards and vineyards was greatly enhanced by the popularity of hobby plots and holiday homes in the 1970s and 1980s.

REFERENCES

- [1] Demény K., A Gödöllői-dombvidék szuburbanizációjának jellemzése. *Tájökológiai Lapok*, 6 (3): 343–349., 2008.
- [2] Koós B., Adalékok a gazdasági szuburbanizáció kérdésköréhez. *Tér és Társadalom* 18 (1): 59–71, 2004.
- [3] Koós, B., Tóth, K., Lakóhelyi és gazdasági szuburbanizáció a közép-magyarországi régióban. In: *A társadalmi földrajz világa: Szegedi Tudományegyetem Gazdasági- és Társadalomföldrajzi Tanszék, Szeged*, pp. 333–342, 2007.
- [4] Santos, M.J., Thorne, J. H., Christensen, J. & Frank. Z., An historical land conservation analysis in the San Francisco Bay Area, USA: 1850–2010. *Landscape and Urban Planning*, 127, 114-123, 2014.
- [5] Swetnam, R. D., Rural land use in England and Wales between 1930 and 1998: Mapping trajectories of change with a high resolution spatio-temporal. *Landscape and Urban Planning*, 81, 91-103, 2007.
- [6] Pătru-Stupariua, I., Stupariub, M-S., Cuculicia, R. & Huzuia, A. (2012) Understanding landscape change using historical maps. Case study Sinaia, Romania. *Journal of Maps*, 7, 206-220, doi:10.4113/jom.2011.1151.
- [7] Popelková, R. & Mulková, M. (2012). Landscape changes mapping: central part of Ostrava-Karviná Mining District, Czech Republic. *Journal of Maps*, 8, 363-375, doi: 10.4113/jom.2011.1165.
- [8] San-Antonio-Gómez, C., Velilla, C., Manzano-Agugliaro, F., Urban and landscape changes through historical maps: The Real Sitio of Aranjuez (1775–2005), a case study. *Computers, Environment and Urban Systems*, 44, 47-58, 2014.
- [9] Skokanová, H., Havlíček, M., Borovec, R., Demek, J., Eremiášová, R., Chrudina, Z., Mackovčín, P., Rysková, R., Slavík P., Stránská T. & Svoboda J., Development of land use and main land use change processes in the period 1836–2006: case study in the Czech Republic. *Journal of Maps*, 8, 88-96, doi: 10.1080/17445647.2012.668768, 2012.
- [10] Tóth, A., Centeri, Cs. Tájváltozás vizsgálat Galgahévíz településen és környékén. *Tájökológiai Lapok*, 6 (1-2) 165-180, 2008.
- [11] Uj, B., Nagy, A., Saláta, D., Laborezi, A., Malatinszky, Á., Bakó, G., Danyik, T., Tóth, A., S. Falusi, E., Gyuricza, Cs., Póti, P. & Penksza, K., Wetland habitats of the Kis-Sárrét 1860–2008 (Körös-Maros National Park, Hungary). *Journal of Maps*, 12, 211-221, 2015.

- [12] Pauleit, S., Ennos, R., Golding, Y., Modelling the environmental impacts of urban land use and land cover change - a study in Merseyside, UK. *Landscape and Urban Planning*, 71, 295-310, 2005.
- [13] Mendoza, J. E., Etter, A., Multitemporal analysis (1940–1996) of land cover changes in the southwestern Bogotá highplain (Colombia). *Landscape and Urban Planning*, 59, 147-158, 2002.
- [14] Befort, W. A., Luloff A. E., Morrone, M., Rural land use and demographic change in a rapidly urbanizing environment. *Landscape and Urban Planning*, 16, 345-356, 1988.
- [15] Vona, M., Helfrich, T. Centeri, Cs., A Galgahévízi láprét felszínborítási viszonyainak változása légifotó elemzések alapján. *Tájökológiai Lapok*, 4 (2). 407-417, 2006.
- [16] Stefanski, J., Chaskovskyy, O., Waske, B., Mapping and monitoring of land use changes in post-Soviet western Ukraine using remote sensing data. *Applied Geography*, 55, 155-164, 2014.
- [17] Maimaitijiang, Maitiniyazi., Ghulam, A., Sandoval, J.S. Onésimo, Maimaitiyiming, Matthew, Drivers of land cover and land use changes in St. Louis metropolitan area over the past 40 years characterized by remote sensing and census population data. *International Journal of Applied Earth Observation and Geoinformation*, 35, 161-174, 2015.
- [18] Romero-Calcerrada, R., Perry, G. L.W., The role of land abandonment in landscape dynamics in the SPA 'Encinares del río Alberche y Cofio, Central Spain, 1984–1999. *Landscape and Urban Planning*, 66, 217-232, 2004.
- [19] Peterson, U., Aunap, R., Changes in agricultural land use in Estonia in the 1990s detected with multitemporal Landsat MSS imagery. *Landscape and Urban Planning*, 41, 193-201, 1998.
- [20] Marosi, S., Somogyi, S., Magyarország kistájainak katasztere II. MTA Földrajztudományi Kutató Intézet, Budapest. pp. 802–806, 1990.
- [21] Galgóczy, K., Pest-Pilis-Solt-Kiskun megye monográfiája. Történelmi, Föld-és Természettudományi, Közhasznú, Társadalmi, Nemzetgazdasági, Régi és Újkori Leírás. Második rész: A megye jelene általában. Kiadja: Weizsmann Testvérek, Budapest, 1877.
- [22] Frisnyák, S., Adalékok a Gödöllői-dombság történeti földrajzához (Tájhasználat a 18–19. században). Herman Ottó Múzeum Évkönyve, Miskolc. 47: 265–294, 2008.
- [23] Tóth, A., Centeri, Cs., Tájváltozás vizsgálat Galgahévíz településen és környékén. *Tájökológiai Lapok*, 6. (1–2): 165–180, 2008/
- [24] Szabó, B., Cneteri, Cs., Vona, M., Turai legelő Természetvédelmi Terület és környezetének tájváltozás vizsgálata katonai térképek alapján. *Tájökológiai Lapok*, 9 (1): 1–11, 2011.
- [25] Kovácsévics, P.(edit.), Magyar erdők. A magyar erdőgazdálkodás. Vidékfejlesztési Minisztérium és a NÉBIH Erdészeti Igazgatóság, 2014.
- [26] Fejes, L., Resztyánszkiné Jackó, V., Az erdőgazdálkodás jellemzői. *Statisztikai Tükör*, 95: 1–6, 2013/

Session 7.

Occupational Safety

FIRE IN INDUSTRIAL FACILITIES FROM THE ASPECTS OF FACILITY SAFETY AND EMPLOYEES HEALTH

Goran Bošković¹, Dejan Ubavin², Milana Ilić Mićunović², Zoran Čepić²

¹University of Kragujevac, Faculty of Mechanical and Civil Engineering, Kraljevo, Serbia

²University of Novi Sad, Faculty of Technical Sciences, Novi Sad, Serbia

e-mail: boskovic.g@mfkv.kg.ac.rs

Abstract: This paper presents an overview of industrial fire research with an emphasis on the three branches of industry: the wood-processing, textile and waste processing. The paper also presents the most common causes that can cause fires in industrial facilities. Also, a proposal of measures by which the fire protection of industrial facilities can be improved and thus reduce the risk of fires or explosions is given.

Key words: industrial fire, fire protection, explosion, waste

INTRODUCTION

Fire protection in industrial facilities is a complex problem, because in addition to the problem of burning of the materials, there is also the possibility of explosions, which especially violates human safety and the impact of fire on the environment. The activity of an industrial facility also raises a special issue of fire protection because it is not possible to extinguish fires of all types of combustible substances with the same type of extinguishing devices. What makes industrial fires characteristic is the great material damage that they can cause, as well as the large emission of harmful gases that adversely affect the environment. Considering that there is a large number of machines, means of transport, combustible substances (raw materials, lubricants, paper ...) in industrial facilities, the possibility of a fire is very certain. The most common causes of fires in industrial plants are:

1. Flammable dust - is characteristic of food, wood processing, pharmaceutical, textile and metal processing industries,
2. Heating and sparking during welding and grinding - typical for the metal processing industry,
3. Improper handling of flammable liquids and gases - these fires, which often occur in chemical plants, and can be catastrophic. One of the common sources of ignition in liquids is static electricity that can occur during fuel spills,
4. Machinery and equipment - faulty equipment and machinery are also causes of industrial fires. Static electricity that occurs in moving parts is a common cause of fire.
5. Faulty electrical installations - Faulty installations cause sparks, overheating or electric arcs, which can be a common cause of fire.

OVERVIEW OF THE MOST COMMON FIRES IN INDUSTRIAL FACILITIES

Fires in the wood processing industry

In the wood processing industry, the greatest risk for the outbreak of fire represents wood dust. Wood dust is a by-product that is created during wood processing, and because the dust particles are barely visible to the naked eye, it represents a great threat to fires and explosions as well as to the health of employees. Explosions and fires caused by igniting a mixture of air and wood dust (dust clouds) are common in wood processing plants. In the paper published by Krentowski, 2015 [1], the explosion of an industrial facility (hall) for the production of plywood and board material caused by self-ignition of a mixture of wood dust and air was analyzed. (Fig.1). The main reason for the occurrence of an explosion is the inadequate ventilation of the machinery used in the process of forming the chipboard. Due to the accumulation of dust in the part of the building (corridor) there was the creation of highly flammable mixture of wood dust and air, whose self-ignition occurred damage that has spread to other parts of the building. Explosion produced an increased air pressure and the shock wave due to an object which is made of prefabricated reinforced-concrete structures have suffered significant damage. In addition to the mentioned explosion, due to the creation of a high temperature which damaged the parts of the structure, additional damage was caused by

the cooling of the elements of the mentioned structure during the fire extinguishing. The deficiency of adequate human oversight of industry control systems has further increased the extent of damage and financial losses.

A similar danger is present in the production of renewable energy sources generated by the processing of biomass - briquettes and pellets. The paper done by Ennis (2016) [2] analyzes the main threats in this type of production, where the leading one is the heat generated due to the storage of wood chips, which is the main raw material for fuel production, as well as the hazards that can occur during transport. The paper also presents measures that can prevent the outbreak of fires and explosions, as well as recommendations based on standards in this area.

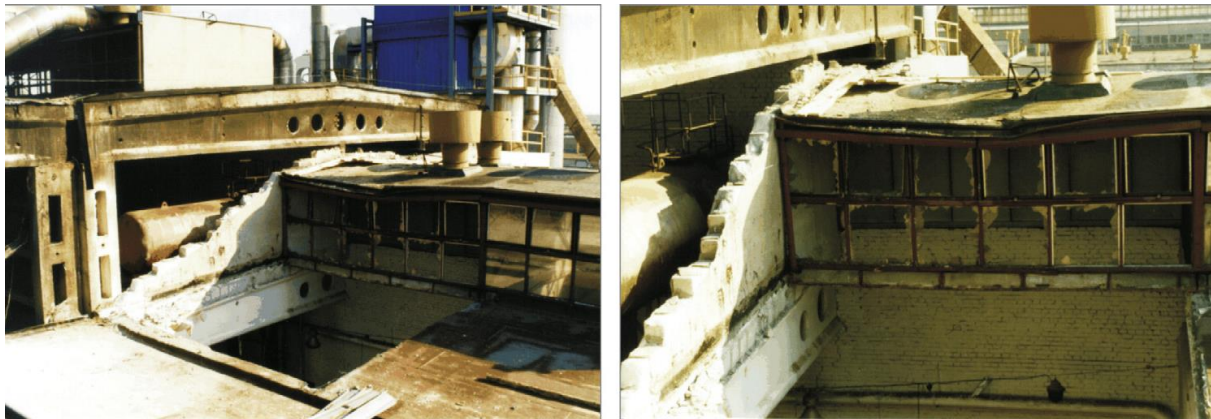

Fig. 1. Appearance of the wood processing industry after the fire and explosion

Fires in the textile industry

Textile production as one of the main branches of industry carries a high risk of fires and explosions. In recent years, there have been more and more accidents in which a large number of employees are injured, especially in Asian countries where the textile industry has experienced the greatest expansion. The textile processing technology itself carries a high risk of creating dust that can be highly flammable, especially in the processing of wool, cotton and other textile fibers in spinning and weaving operations.. In the paper published by Ponnusamy et. all (2019) [3] were analyzed all of the possible conditions that may cause a fire or explosion in the textile industry. It is stated that improper safety measures at work and fire protection can cause great material damage, and in the worst case, the loss of many human lives. (Fig.2). In the paper done by Lina et. all (2011) [4] using the Fire Dynamics Simulator software (FDS) a simulation of a fire was made in a three-storey building with an area of about 12000 m², which is a facility in which textile raw materials are stored and in which further production into the finished product is performed. The analysis of the obtained results revealed interesting facts that can serve as a basis for further research and development of protection rules in the textile industry.



Fig.2 Textile industry facility after fire

In the paper published by Marmo et. all [5] a scenario and results are reconstructed of papers dealing with the subject of 4 fires which occurred in the textile industry with characteristic data related to materials and conditions in which processing was performed. The paper done by Piccinini (2008) [6] analyzes the explosion that occurred in a wool processing factory in Italy. The explosion is a consequence of the ignition of a cloud of dust particles of wool particles, which was most likely initiated by a spark from the lighting system. A detailed analysis revealed that the explosion occurred by burning several layers of dust, the spark caused the dust clouds to ignite, and after that deflagration occurred, which caused an explosion inside the factory.

Fires in the recycling industry

As the awareness of the reuse of material changed, so the recycling industry has progressed and expanded the range of materials that can be processed. Fires in facilities for processing and storage are important economic, social and environmental challenges. Lately, the more frequent recycling of electronic waste (computers, white goods, batteries ...) that represents a high risk and a big waste is imperative to provide adequate fire protection during storage and processing of the same. In paper done by Nigl et. all (2019) [7], a comprehensive analysis of 285 fires in recycling facilities that occurred in Austria over a decade was conducted. As for the places where fires most often occur, in waste processing plants it is in the case of crushing machines, because it is never possible to predict in advance whether there are, for example, old pressurized bottles in recycled metal waste that can initiate a fire or explosion. Understanding the causes of fire in waste management, disposal and recycling, as well as the shortcomings in terms of people's knowledge of this area, which must be constantly upgraded, and mentioned paper emphasizes this.

Research and simulations of fires in the recycling facility that caused serious damage to the warehouse and the recycling facility itself, were conducted within the chapter published by Romano (2019) [8]. Due to the lack of adequate active and passive measures to protect buildings from fire and poor operational warehouse management, it was not possible to prevent the formation of fire. In this regard, it is necessary to establish new criteria for fire prevention in plants of this type. An overview of the characteristic large industrial fires is given in the project report don by Ingason et. all [9]. Deeper analysis of specific fire led to the confirmation of certain data for the mathematical model for calculating the fire spread between buildings affected by the fire. The biggest problem when assessing the risk and danger of fire is the determination of input parameters in the calculation model, and one of the most important is the rate of heat release.

Study published by Ministry of the Environment, Energy and the Sea in France (2016) [10] is based on an analysis of 1100 accidents that occur in the waste management activities and took place over a period of 10 years. Within the aforementioned study identified different causes of causing fire in plants for waste recycling, and some of them are self-ignition temperature, welding places as sources of heat, friction, faulty electrical installations and others.

MEASURES FOR REDUCING RISK OF FIRE OUTBREAKS IN INDUSTRIAL FACILITIES

The main goal when designing an industrial plant is to enable the proper functioning of the production process without great danger to human life and health, as well as the protection of the environment and the facility itself from destruction. Certain laws are defined measures and procedures for fire protection that must be respected.

In industries such as wood processing, the following procedures must be followed:

- Provide adequate ventilation and drainage of sawdust and dust generated during wood processing in the area of the machines themselves,
- Further drainage and storage of sawdust outside the building with the help of cyclones or silos for sawdust,
- Regularly perform preventive inspection of machines and equipment as well as electrical installations due to the appearance of static electricity and sparks that can be a source of ignition,
- Install early fire alarm systems and automatic fire extinguishing systems of the sprinkler system type (Fig.3).

In industries such as textiles, the following procedures must be followed:

- Provide adequate ventilation of production facilities,

- Regularly maintain the hygiene of the floor of the building due to the deposition of textile dust,
- Prevent unnecessary accumulation of raw materials,,
- Regularly perform preventive inspection of machines and equipment as well as electrical installations due to the appearance of static electricity and sparks that can be a source of ignition,.
- Install early fire alarm systems and automatic fire extinguishing systems of the sprinkler system type (Fig.3).

Due to the specifics of the types of raw materials that are processed within the recycling industry, the guidelines that should be followed are:

- When storage of waste materials that are prone to self-heating, carried out checking temperature and humidity, since it can cause spontaneous combustion,
- Install ventilation systems that reduce the risk of fire by removing various gases and vapors,
- If possible, perform sorting and sorting of waste,
- When recycling metal, pay attention to waste in the form of vessels or pressure bottles, which can cause fires and explosions,
- Install early fire alarm systems and automatic fire extinguishing systems of the sprinkler system type (Fig.3).



Fig.3 Fire detection (alarm system) and sprinkler fire extinguishing system

CONCLUSION

Accidents that occur due to poor fire protection measures can cause great material damage to industrial facilities, and in some cases such events end in casualties. The paper deals with three branches of the processing industry where fires and explosions often occur - wood-processing, textile and recycling industries. What is common for the wood-processing and textile industry is the fact that in both production processes there is a large amount of dust that can create a very flammable and explosive mixture with air. For the recycling industry, it is important to mention that due to the large number of flammable substances that are processed in the process of waste processing, there is a high risk of fire, which is due to self-heating of waste or waste with sufficient and very small ignition source to cause potential fire. The last chapter also provides guidelines - measures that can reduce the risk and possibility of fires in these three industries.

ACKNOWLEDGMENTS

This paper has been supported by the Ministry of Education, Science and Technological Development through the projects no. 451-03-68/2020-14/200156 and 451-03-68/2020-14/200108. This support is gratefully acknowledged.

REFERENCES

- [1] Krentowski, J., Disaster of an industrial hall caused by an explosion of wood dust and fire, *Engineering Failure Analysis*, No.56, pp.403-411, 2015.
- [2] Ennis, T., Fire and Explosion Hazards in the Biomass Industries, *IchemeE (Institution of Chemical Engineers) Symposium Series*, No.161, pp.1-9, 2016., Available at www.icheme.org/media/11801/hazards-26-paper-64-fire-and-explosion-hazards-in-the-biomass-industries.pdf
- [3] Ponnusamy, V., Paulraj, P., Palanisamy, S., Kanchana, S.,: Fire safety in textile industries - A Review, *Industria Textila*; Vol.70, No.6, pp.523-526, 2019.
- [4] Lina, C., Wub, M., Tsaic, S.: A Case Study on a Fire Disaster in a Textile Factory, *Applied Mechanics and Materials*, Vol.763, pp.134-139, 2015.
- [5] Marmo, L., Ferri, A., Danzi, E.: Dust explosion hazard in the textile industry, *Journal of Loss Prevention in the Process Industries*, Vol.62, pp.1-11, 2019.
- [6] Piccinini, N.: Dust explosion in a wool factory: Origin, dynamics and consequences, *Fire Safety Journal*, Vol.43, pp.189-204, 2008.
- [7] Nigl, T., Rübenauber, W., Pomberger, R.: Cause-Oriented Investigation of the Fire Incidents in Austrian Waste Management Systems, *Detritus*, pp.1-8, 2019., Article in press.
- [8] Romano, G., Romano, A.: Fire investigation in an Italian waste treatment plant: lessons learned and future development, *Safety and Security Engineering*, Vol.189, pp.113-119, 2019.
- [9] Ingason Tuovinen, H. and Lönnermark, A.: Industrial fires - An Overview, *SP Technical Research Institute of Sweden*, 2010, Available at www.diva-portal.org/smash/get/diva2:962537/FULLTEXT01.pdf
- [10] Overview of accident statistics on waste management facilities, *Ministry of the Environment, Energy and the Sea, France*, 2016, Available at <https://www.aria.developpement-durable.gouv.fr/wp-content/uploads/2017/06/2016-10-11-SY-AccidentologieDechetsVersionSimplifiee-PA-EN-Vfin.pdf>

CONTRIBUTION TO THE SAFETY ANALYSIS DURING OPERATION WITH TRUCK-MOUNTED CRANE

Goran Bošković^{1*}, Dejan Ubavin², Dragan Adamović², Zoran Čepić²

¹University of Kragujevac, Faculty of Mechanical and Civil Engineering, Kraljevo, Serbia

²University of Novi Sad, Faculty of Technical Sciences, Novi Sad, Serbia

*e-mail: boskovic.g@mfkv.kg.ac.rs

Abstract: This paper presents an analysis of the causes of the most common injuries when working with crane machines. The paper also presents the statistics of injuries at work when using cranes and presents measures that can reduce injuries at work. Transport of cargo and materials is unimaginable without the use of cranes and various transport systems. The technologies used today in the construction and manufacturing of cranes, as well as certain safety and sensor systems, have significantly improved their safety and surpassed the ability of people to safely operate them. Despite all these sophisticated solutions, accidents often occur on construction sites, where in most cases the human factor is mentioned as the reason.

Key words: crane machines, injuries, safety at work

INTRODUCTION

Cranes (cranes) over many years of application in various branches of industry have become the most dominant transport devices for handling of cargo in all forms (powders, liquids, solids, gases ...). The roughest division of cranes by type and area of industry in which it is applied is shown on Fig. 1. The accelerated development of the machine, construction, transport and process industries has forced the construction and production of dedicated cranes that will be used in the mentioned areas (bridge crane, tower-construction crane, portal crane, etc.) [1].

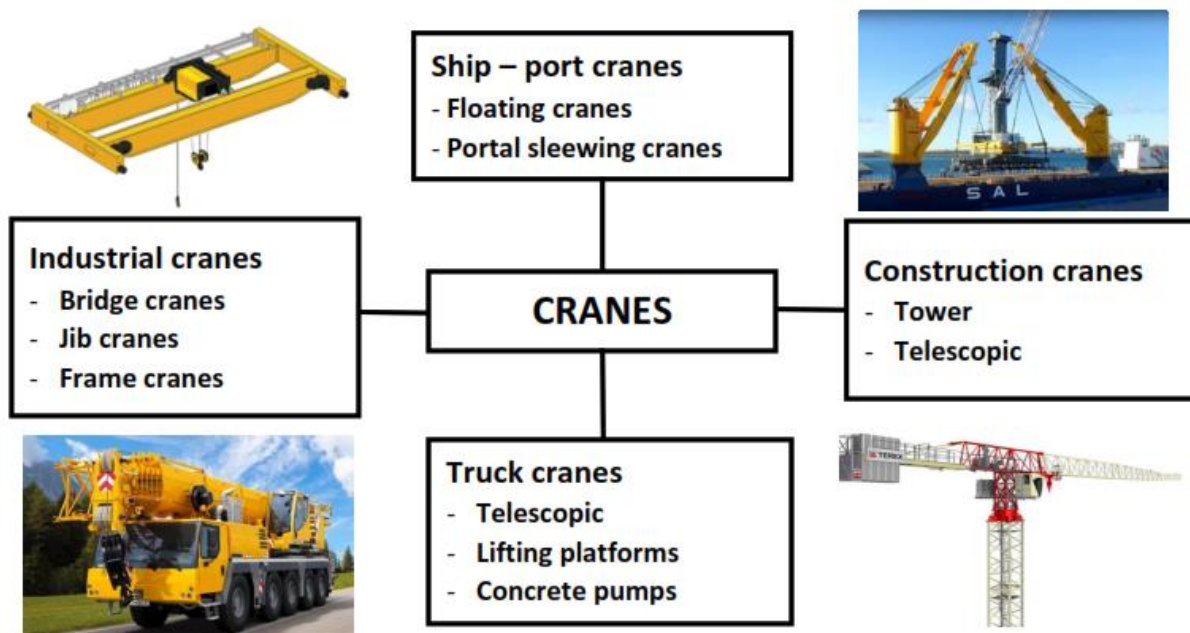

Fig. 1. General division of cranes

The rapid expansion of the construction industry after the 1950s imposed the need for the development and production of transport devices and machines that would significantly facilitate the process of construction and maintenance of construction, housing and communal infrastructure, as well as handling and transport of various loads in conditions of limited maneuvering space and lifting height [2, 3]. As a characteristic representative of cranes that have found the most common application in the mentioned activities and processes, truck cranes are distinguished. Since the appearance of the first

type of crane produced by the Swedish company HIAB in 1947, which was a hydraulic crane mounted on a truck, to this day these cranes have undergone major design changes and today represent complex systems that can meet many requirements in terms of their application.

As characteristic areas for the application of these cranes, the following stand out:

- application in the construction industry,
- transport and handling in the metal, process and wood processing industries,
- maintenance of communal and traffic infrastructure, greenery and parks,,
- use for police and military purposes,
- use in evacuation, rescue and firefighting.

POSSIBLE PROBLEMS DURING THE HANDLING OF TRUCK-MOUNTED CRANE

Truck - mounted crane, as transport device for moving heavier loads during their work, carry a number of dangers, both for operators and for workers who are in the immediate vicinity of the crane. Due to the pronounced mobility - the ability to quickly change locations and the ability to lift loads (up to 1200 tons) and reach the working device (up to 100 meters), which significantly increases the maneuvering space, this type of crane raises a significant question about the safety of operators and all workers involved in the transport process of cargo. Dangers (threats) that can occur when working with truck - mounted cranes are:

- the risk of loss of stability (overturning) of crane,
- risk of electric shock upon contact with the high voltage network,
- hazards from external negative influences (noise, vibrations, temperature, humidity),
- the risk of their own effort (physical and mental) operator during operation
- danger of traffic accidents (due to vehicle dimensions).

Loss of stability of the truck-mounted crane is a very complex and important problem that can ultimately cause the crane itself to overturn (Figure 2a), and most often occurs due to:

- exceeding the carrying capacity of the crane.
- improper installation of stabilizers,
- strong gusts of wind,
- unstable ground on which the crane rests,
- poor linkage (suspension) of the cargo.

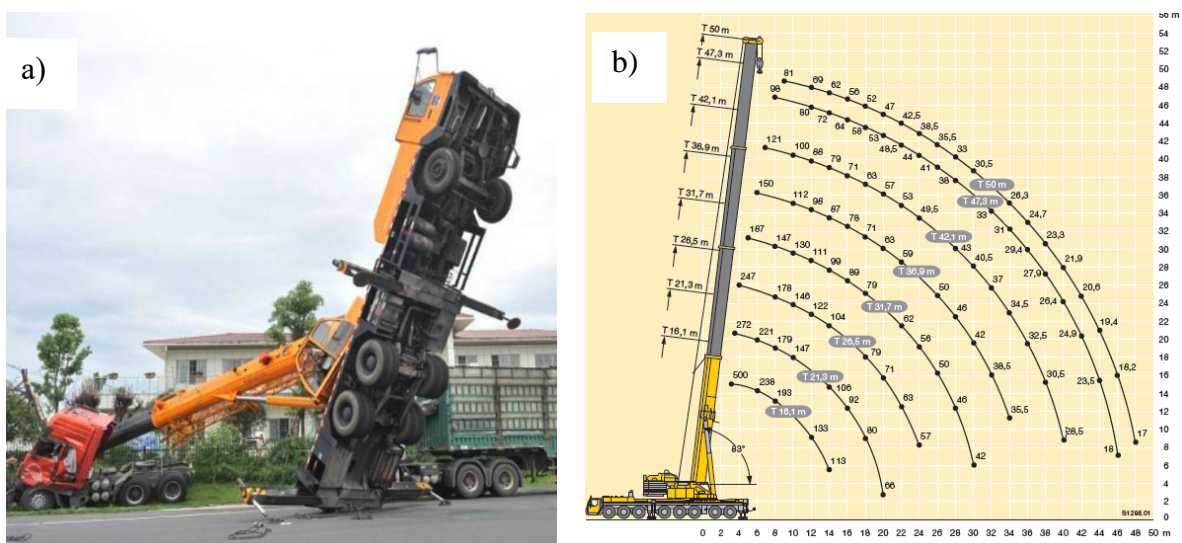

Fig. 2. a) An example of a crane overturning due to overload, b) Truck-mounted crane load diagram

Exceeding the load capacity of the crane itself is the most common cause of accidents and accidents on construction sites and in most cases is due to ignorance of the load capacity parameters of the

crane, as reduced use of appropriate load diagrams (Figure 2b) which are part of the technical documentation the load can be lifted by the crane depending on the angle of the boom and the length (place) where the load is suspended. The crane operator must be familiar with all important parameters such as: crane load capacity, reach, boom turning radius, maximum boom reach angle.

Increasing the stability of the crane from overturning is achieved by using appropriate telescopic stabilizers that counteract the moment of force from the weight of the crane and the load that is suspended.

Wind is a major threat to the boom because of the wind velocity profile changes with increasing altitude, or close to the ground in the form of a weak breeze while at heights of 30 meters or higher speed can be significantly higher. The wind can thus reduce the capacity of the crane, and at the same time be an additional component of the moment of force, which can lead to a breakdown and overturning of the crane itself.

Regardless of the type and type of crane, their use must comply with significant measures and procedures related to safety at work due to the specific operations that take place during their use.

STATISTICS ON ACCIDENTS WITH TRUCK-MOUNTED CRANES

According to the statistics of International Labour Organization (ILO), the highest percentage of accidents with cranes as much as 72% is related to mobile cranes, which is shown in the diagram (Fig. 3) [4, 5]. The graph is given for the European Union, North America and other countries where statistics is conducted. The types of cranes covered by this statistic are car cranes, construction cranes, bridge cranes, port cranes as well as lifting platforms. As is obvious, the largest number of accidents with cranes occurs in North America. The most common causes of these accidents with the mentioned types of cranes are: crane overturning 45%, crane construction failure 9% (most often due to crane contact with high voltage electrical installations), traffic accidents 7% and load fall from height due to poor suspension 3%.

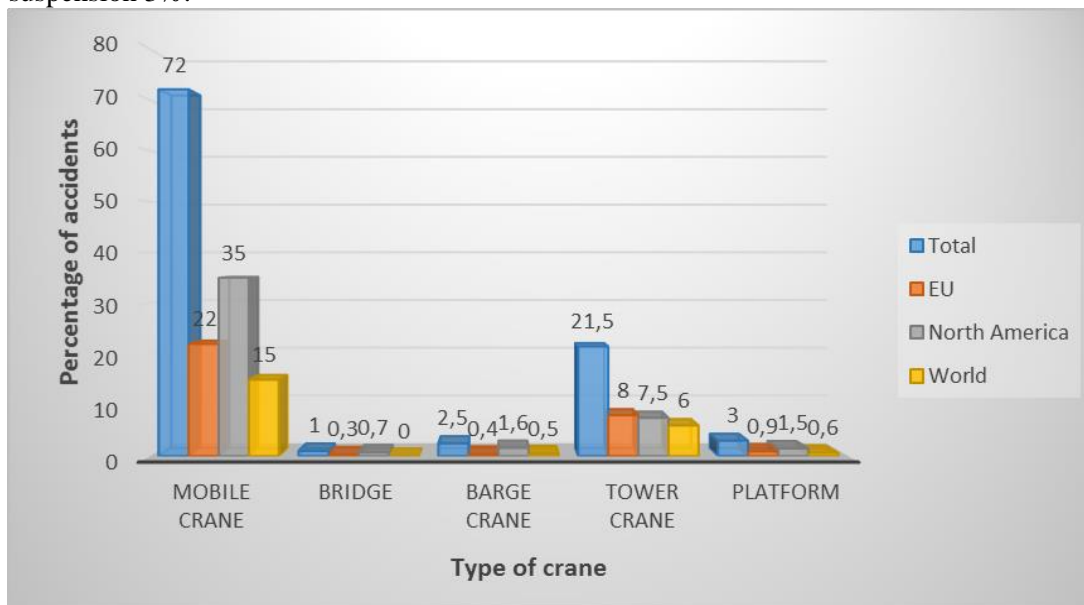

Fig. 3. Graphic representation of accidents with cranes by type in relation to the location where they are located

It is important to mention the data that were created on the basis of the analysis of 1000 accidents in the last 20 years in which the final outcome was the overturning of the crane and which were caused by:

- in 15% cases were traffic accidents,
- in 39% of cases turning of the boom with the load with poorly placed stabilizers,
- in 15% of cases lifting loads without installed stabilizers,
- in 14% of cases lifting load that is not in accordance with the crane load diagram,
- in 7% of cases the stabilizers are incorrectly turned or placed,

- in 10% of cases accidents occur due to other activities.

According to the statistics of International Labour Organization (ILO):

- in 6% of truck-mounted crane accidents it ends in death,
- in 44% of accidents with truck-mounted cranes there are injuries to workers or operators,
- in 50% of accidents only material damage occurs.

In almost 90% of accidents, the reason is in the human factor, that is the crane operator [6].

MEASURES TO IMPROVE SAFETY AT WORK WITH TRUCK-MOUNTED CRANES

Truck-mounted cranes represent transport devices or machines with increased hazards at work, so the basic step in improving safety is to check the correctness of the crane and conduct preventive and periodic inspections. Application and implementation of regulations in the field of safety at work with cranes, refers to the creation of safe and healthy conditions for work with cranes, which aims to reduce injuries at work and occupational diseases during their use. In this regard, it is necessary to constantly work on improving and enhancing the safe operation of cranes through the full application of regulations in the field of safety of machines with joint activities of employers, employees and professionals in the field of safety at work, all with the aim of improving safety, raising awareness in this area as well as education and improvement of knowledge and skills when working with cranes. In addition to all the above, the application and implementation of appropriate regulations governing safety at work with cranes, significantly affects the development and improvement of the culture of prevention when working with cranes [7]. As an important factor in the field of safety at work, it must have an education system through which, by improving the knowledge, competencies and expertise of employees, awareness of the importance of safety and health of oneself and others is developed..

In the territory of the European Union, good practice in safety at work in crane management has been noticed in countries that often invest large funds in education and raising awareness that safe work is what each of the employed individuals deserves.

CONCLUSIONS

Accidents that occur when using truck-mounted cranes can cause great material damage, and even the accident can be fatal. The importance of safety at work nowadays is underestimated by many, but the fact is that a safe work environment is not only important from the aspect of health, but it also has economic significance, which is important for employees as well as for the company and society as a whole. It is important to emphasize that in addition to the stated benefits that are realized by applying the regulations related to safety at work, safe work significantly affects the motivation of employees and thus affects the quality of work. This confirms that Western countries are progressing faster than smaller countries due to the fact that they are developing prevention mechanisms and applying appropriate regulations and regulations related to safety and health at work.

ACKNOWLEDGEMENT

This paper has been supported by the Ministry of Education, Science and Technological Development through the projects no. 451-03-68/2020-14/200156: "Innovative scientific and artistic research from the FTS domain" and 451-03-68/2020-14/200108. This support is gratefully acknowledged.

REFERENCES

- [1] Ostrić D. "Cranes", Faculty of Mechanical Engineering Belgrade, Belgrade 1992.
- [2] Tošić S. "Transport devices", Faculty of Mechanical Engineering Belgrade, Belgrade 1992.
- [3] Bošković G., Marković G., Savković M., Zdravković N.: "Review of the Dynamic and Mathematical Models of Portal Slewing Cranes", IMK-14 – Research & Development in Heavy Machinery, Vol.22, No.4, 2016, EN115-120
- [4] <https://www.ilo.org/>

- [5] Stanković D.: “A Contribution to the Improvement of Conditions for the Safe Operation of Cranes”, IMK-14 – Research & Development in Heavy Machinery, Vol.22, No.2, 2016, EN61-68
- [6] Milazzo M.F., Ancione G., Spasojevic Brkic V., Vališ D.: “Investigation of crane operation safety by analysing main accident causes”, Chapter in book: Risk, Reliability and Safety: Innovating Theory and Practice, CRC Press, London (2016)
- [7] SRPS EN ISO 12100:2014 Bezbednost mašina - Opšti principi za projektovanje - Ocena rizika i smanjenje rizika.

AN APPROACH FORWARD TO DIGITALIZATION OF WORKPLACE RISK ASSESSMENT AND MONITORING

Mirjana Misita¹, Vesna Spasojević-Brkić¹, Maritna Perišić¹,
Marija Milanović¹, Ankica Borota-Tišma²

¹University of Belgrade, Faculty of Mechanical Engineering, Belgrade, Serbia

²Belgrade Business and Arts Academy of Applied Studies, Belgrade, Serbia

e-mail: mmisita@mas.bg.ac.rs

Abstract. This paper presents an approach to the digitalization of the workplace risk assessment and monitoring process. Workplace risk was assessed using the “5x5” method. Workplace are spatially distributed in the observed factory. The summary risk assessment is presented visually and the high-risk workplace is marked. The map is made dynamically so that the job estimates on the diagram changes if there is a change in the input data for any of the identified sources of risk.

Key words: workplace, risk assessment, risk monitoring.

INTRODUCTION

In the scientific and professional literature, the problem of automatic monitoring of danger and hazard in the workplace is a very current topic [3],[5],[9],[10]. However, with the development of information technologies, the model of automatic monitoring of danger and hazards in the workplace can be significantly improved. Numerous papers in scientific and professional literature testify that. Workers employed in manufacturing companies are particularly exposed to health dangers and hazards [15]. In construction as well, and therefore in the literature [4] it can be found papers of the necessity of development of the real-time safety risk assessment methodology for indentation dynamic evaluation of worker safety states on construction site.

Mayer et al. [8] as result of trans-national project for assessment and management of risk for engineered systems and geohazards conclude that appropriate simulation procedures are indispensable and gives necessary information for risk evaluation, successful risk management and communication.

With the development of information technology and the creation of the I4.0 environment, numerous papers indicate the need to develop methodologies for risk assessment online [14], [2], [8], [1].

The aim of this research is to examine the possibilities digitization of monitoring of danger and hazards in the workplace by implementing modern information technologies in order to increase the quality of the process of monitoring and risk assessment as well as increasing the safety of workers in the workplace.

METHOD OF WORKPLACE RISK ASSESMENT AND MONITORING

Workplace danger and hazard risk assessment is carried out using Kenny method or “5x5” matrix method. The methodology is based on expert identification of danger and hazard at each workplace in the observed factory. Factory INSA ad. - industry of watches, water meters and other measuring instruments was chosen as an example of application of methodologies. During the identification and assessment of dangers and hazards at the workplace and in the work environment, 85 workplaces were analyzed in the observed company. For the purpose of presenting the approach of the automated procedure of workplace risk assessment and monitoring, 10 jobs were selected. Those jobs are: president, storekeeper, foreman in the organizational unit machining, automatic lathe controller, metal lathe, auxiliary worker, grinder, technologist in surface protection, galvanizer, painter. All selected jobs were marked and coded consecutively as previously mentioned – WP – Workplace, and then entered their location on the spatial plan of the factory [6], Fig. 1.

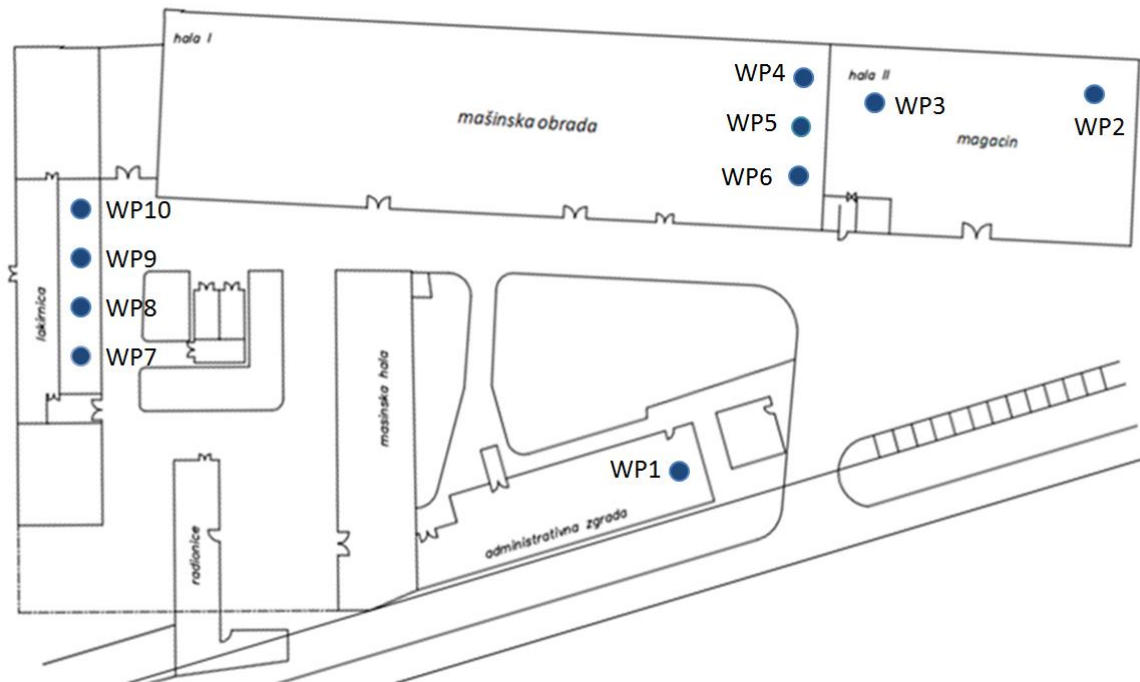

Fig. 1. Workplace spatial layout

The next step is the application of the 5x5 methodology for the identification of danger and hazard in selected workplaces. Table 1 lists and numbers the different sources of risk identified for each workplace.

Table 1. Risk numeration by workplace

WP1	WP2	WP3	WP4	WP5	WP6	WP7	WP8	WP9	WP10
1.1.1.	2.1.1.	3.1.1.	4.1.1.	5.1.1.	6.1.1.	7.1.1.	8.1.1.	9.1.1.	10.1.1.
1.1.2.	2.1.2.	3.1.2.	4.1.2.	5.1.2.	6.1.2.	7.2.2.	8.1.2.	9.1.2.	10.1.2.
1.2.1.	2.2.1.	3.1.3.	4.1.3.	5.1.3.	6.1.3.	7.2.3.	8.1.3.	9.1.3.	10.1.3.
1.2.2.	2.2.2.	3.2.1.	4.1.4.	5.1.4.	6.1.4.	7.2.4.	8.2.1.	9.1.4.	10.1.4.
1.2.3.	2.2.3.	3.2.2.	4.1.5.	5.1.5.	6.1.5.	7.2.5.	8.2.2.	9.2.1.	10.2.1.
1.2.4.	2.2.4.	3.2.3.	4.1.6.	5.1.6.	6.1.6.	7.2.1.	8.2.3.	9.2.2.	10.2.2.
1.2.5.	2.2.5.	3.2.4.	4.1.7.	5.1.7.	6.1.7.	7.2.2.	8.2.4.	9.2.3.	10.2.3.
	2.2.6.	3.2.5.	4.1.8.	5.1.8.	6.1.8.	7.2.3.	8.2.5.	9.2.4.	10.2.4.
		3.2.6.	4.2.1.	5.2.1.	6.2.1.	7.2.4.	8.2.6.	9.2.5.	10.2.5.
		3.2.7.	4.2.2.	5.2.2.	6.2.2.	7.2.5.	8.2.7.	9.2.6.	10.2.6.
		3.2.8.	4.2.3.	5.2.3.	6.2.3.	7.2.6.	8.2.8.	9.2.7.	10.2.7.
			4.2.4.	5.2.4.	6.2.4.	7.2.7.		9.2.8.	10.2.8.
			4.2.5.	5.2.5.	6.2.5.	7.2.8.		9.2.9.	10.2.9.
			4.2.6.	5.2.6.	6.2.6.				
			4.2.7.	5.2.7.	6.2.7.				
			4.2.8.	5.2.8.	6.2.8.				
			4.2.9.	5.2.9.	6.2.9.				

The following is a description of the risk assessment for workplace number 9, WP8 – galvanizer. The list of tools used by the worker in this workplace is listed first, followed by the list of protective equipment required in this workplace.

Description of galvanizing tools [7]:

- Within the galvanization department, the following equipment is present:
- Nickel plating line
- Copper cyanide and high-luster plating line
- Brass line
- Cadmium plating line
- Zinc plating line
- Brass etching line
- Line for anodizing and passivation of aluminum
- Container for removing galvanic coats

Description of equipment for personal protection [5]:

- Work suit or acid-resistant clothing
- Rubber boots or ribbed rubber-sole shoes
- Work gloves
- Safety goggles with side protection
- Protective mask over mouth and nose if needed
- Protective cap if needed

Further, the source of risk for this workplace was identified. Since the workplace is designated as WP9, all risk sources are numbered 9.1.X for danger and 9.2.X for hazard.

Recognition of risk and possible hazard in the workplace and environment -WP9

Danger recognition (9.1) [7]:

9.1.1. Danger of falling due to slipping on wet floor surfaces

9.1.2. Danger of being hit by a transportation vehicle (forklift).

9.1.3. Risk of direct contact with energized electrical components and equipment.

9.1.4. Risk of indirect contact with live electrical parts (if a fault between a live part and an exposed-conductive-part occurs).

Hazard recognition (9.2) [7]:

9.2.1. Chemical hazard caused by inhalation of various vapors, dust and fumes that occur during the work process in the galvanization department or during other technological processes that are performed near the workplace.

9.2.2. Chemical hazards that occur during work by direct contact with chemicals used in the process.

9.2.3. Physical hazards caused by noise.

9.2.4. Harmful effects of microclimate (temperature, air humidity and air flow).

9.2.5. Inadequate/Insufficient lighting conditions in the workplace.

9.2.6. Non-physiological body position (frequent standing).

9.2.7. Efforts in performing certain tasks causing psychological strain (stress, monotony, etc.).

9.2.8. Hazard related to work management (overtime work, working in shifts, night work, etc.).

9.2.9. Other possible hazards such as use of inadequate repromaterials, use of inadequate tools, instruments, change of workplace due to production process requirements.

Furthermore, for identified sources of risk, an assessment was conducted according to the “5x5” methodology.

Table 2. Risk assessment in terms of hazard and danger for galvanizer workplace [7]

Label	Hazard or danger description	Severity of injury or illness	Probability of occurrence	Risk level
9.1.1	Danger of falling due to slipping on wet floor surfaces	Moderate	Likely	Medium
9.1.2	Danger of being hit by a transportation vehicle (forklift)	Fatal	Unlikely	Medium
9.1.3	Risk of direct contact with energized electrical components and equipment	Moderate	Likely	Medium

Table 2. Risk assessment in terms of hazard and danger for galvanizer workplace [7] (continued)

9.1.4	Risk of indirect contact with live electrical parts (if a fault between a live part and an exposed-conductive-part occurs)	Moderate	Likely	Medium
9.2.1	Chemical hazard caused by inhalation of various vapors, dust and fumes that occur during the work process in the galvanization department or during other technological processes that are performed near the workplace	Significant	Very Likely	High
9.2.2	Chemical hazards that occur during work by direct contact with chemicals used in the process	Moderate	Very Likely	High
9.2.3	Physical hazards caused by noise	Minor	Likely	Medium
9.2.4	Harmful effects of microclimate (temperature, air humidity and air flow)	Moderate	Very Likely	High
9.2.5	Inadequate/Insufficient lighting conditions in the workplace	Negligible	Likely	Low
9.2.6	Non-physiological body position (frequent standing)	Negligible	Very Likely	Low
9.2.7	Efforts in performing certain tasks causing psychological strain (stress, monotony, etc.)	Negligible	Likely	Low
9.2.8	Hazard related to work management (overtime work, working in shifts, night work, etc.)	Minor	Likely	Medium
9.2.9	Other possible hazards such as use of inadequate repromaterials, use of inadequate tools, instruments, change of workplace due to production process requirements	Minor	Very Likely	Medium

According to above risk assessment it could be concluded that galvanizer is a high-risk workplace. Similarly, a risk assessment was conducted for other workplaces. All sources of risk (127 in total) for the observed 10 workplaces, and their dangers and hazards estimates were entered into the database, Table 2. Conditional formatting, the classification of risk sources with the terms 'LOW', 'MEDIUM' and 'HIGH' in appropriate format.

Table 3. Workplace risk assessment

98	WP8	8.2.5.	Insignificant (no sick leave)	1	4	Likely	4	LOW
99	WP8	8.2.6.	Insignificant (no sick leave)	1	3	Possible	3	LOW
100	WP8	8.2.7.	Insignificant (no sick leave)	1	3	Possible	3	LOW
101	WP8	8.2.8.	Insignificant (no sick leave)	1	3	Possible	3	LOW
102	WP9	9.1.1.	Medium (sick leave over 3 working days)	3	3	Possible	9	MEDIUM
103	WP9	9.1.2.	Severe (long-term illness)	4	2	Rare	8	LOW
104	WP9	9.1.3.	Medium (sick leave over 3 working days)	3	3	Possible	9	MEDIUM
105	WP9	9.1.4.	Medium (sick leave over 3 working days)	3	3	Possible	9	MEDIUM
106	WP9	9.2.1.	Severe (long-term illness)	4	4	Likely	16	HIGH
107	WP9	9.2.2.	Medium (sick leave over 3 working days)	3	Rare Unlikely Possible		12	MEDIUM
108	WP9	9.2.3.	Easy (pain up to 3 working days)	2	Likely		6	LOW
109	WP9	9.2.4.	Medium (sick leave over 3 working days)	3	Almost certain		12	MEDIUM
110	WP9	9.2.5.	Insignificant (no sick leave)	1	3	Possible	3	LOW
111	WP9	9.2.6.	Insignificant (no sick leave)	1	4	Likely	4	LOW
112	WP9	9.2.7.	Insignificant (no sick leave)	1	3	Possible	3	LOW
113	WP9	9.2.8.	Easy (pain up to 3 working days)	2	3	Possible	6	LOW
114	WP9	9.2.9.	Easy (pain up to 3 working days)	2	4	Likely	8	LOW

Furthermore, data preparation was performed (Table 2), in which the coordinates of workplaces of the spatial distribution of the factory are given. And then the coordinates of the workplaces are linked to the table in Figure 1, by the the workplace risk assessment. Given that there are several sources of risk in one workplace, it was taken to alert the grades with highest value according to the “5x5” methodology, as the max RNP (calculated in Table 2).

Table 4. Data preparation table for online workplace risk assessment

data preparation				
x	y	wp	Description	Max
2,95	1,50	WP1	president	9
4,65	3,80	WP2	storekeeper	9
3,75	3,75	WP3	auxiliary worker	12
3,46	3,90	WP4	controller	12
3,45	3,60	WP5	metal lathe	9
3,44	3,30	WP6	auxiliary worker	9
0,5	2,20	WP7	grinder	12
0,5	2,50	WP8	technologist	12
0,5	2,80	WP9	galvanizer	16
0,5	3,10	WP10	painter	16

Figure 2, gives the final of the estimates on the spatial layout of the factory, which is used to monitor workplace risks. Workplace 9 and workplace 10 are the workplaces with high risks, and workplaces 3,4,7,8 are workplaces with medium risk, while workplaces 1,2,5,6 are workplace with low risk.

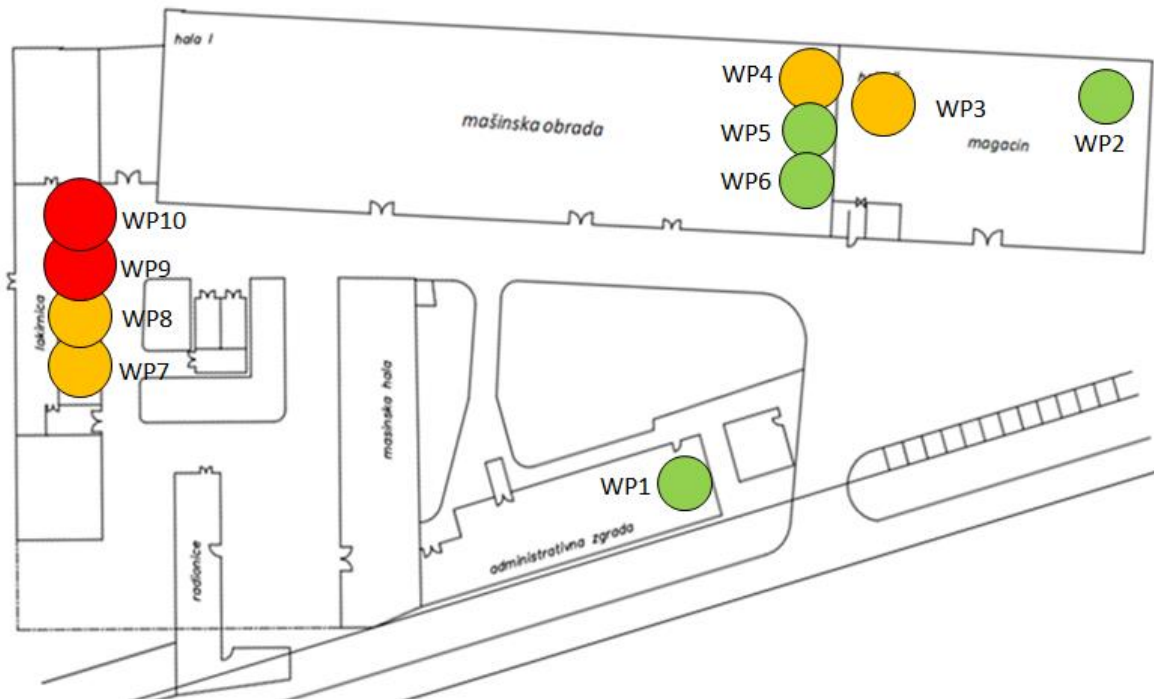

Fig. 2. Workplace risk monitoring

In this way, risk managers can easily identify high-risk workplaces and plan priority activities events and protect employees in the workplace. Also, the software application makes it possible to show separately the workplaces with the highest risk of dangers to the health of workers.

CONCLUSION

The conducted research aims to increase the quality of the workplace risk assessment procedure as well as to more efficiently implement the procedure of protection of workers from unwanted events. Also, the proposed method of workplace risk assessment enables online monitoring of workplace risks, as well as visual representation and activation of alarm signals in order to prevent unwanted and dangerous events in the workplace, applicable for any any business-production company.

The research points to easier monitoring of workplace risk by using a database that automatically displays workplace risk assessment (low, moderate, high) as well as risk visualization by spatial layout, but the limitation of the model is the entering of input data for identified risks. Namely, the identification of risk sources for each job should be done by a professional risk assessor (this assessment is usually done on an annual basis), while the monitoring of certain risk sources can be carried out by trained staff, or automatically - through cyber physical systems for certain measurable risk sources.

However, further research should be focused on resolving the issues of entering input data (ie considering the possibility of implementing sensors for monitor parameters that affect risks at the workplace), development of expert knowledge base, data storage in the cloud, online access for the all relevant users, group decision-making in the case of multiple risk assessors and similar issues.

ACKNOWLEDGEMENT

This paper is supported by grants from the Ministry of Education, Science and Technological Development, grants from project E!13300 and contract 451-03-68/2020-14/200105 (subproject TR 35017).

REFERENCES

- [1] Aven, T., Risk assessment and risk management: Review of recent advances on their foundation, *European Journal of Operational Research*, Vol. 253(1), pp. 1-13, 2016.
- [2] Gašova, M., Gašo, M., Štefanik, A., Advanced industrial tools of ergonomics based on Industry 4.0 concept, *Procedia Engineering*, Vol.192, pp. 219-234, 2017.
- [3] Hahm, M., Lee, J., Lee, M., & Byeon, S.-H. (2016). Health risk assessment of occupational exposure to styrene depending on the type of industry: Data from the Workplace Environmental Monitoring Program in Korea. *Human & Ecological Risk Assessment*, 22(6), 1312–1322.
- [4] Hanchen, J., Peng, L., Qixiang, F., Maoshan Q., Real-Time Safety Risk Assessment Based on a Real-Time Location System for Hydropower Construction Sites, *Scientific World Journal Hindawi Publishing Corporation*, Vol.2014, Article ID 235970, pp.1-14, 2014.
- [5] Imangazin, M., Almatova, B. and Allanova, R. (2016) 'Identification and Risk Assessment of Hazard Occurrence at the Aksu Ferroalloys Plant During 2007-2012', *Metallurgist*, 59(11/12), pp. 1152–1156.
- [6] Insa a.d., Documentation about factory - Serbian manufacturer of clocks & other measurement instruments, 2020.
- [7] Insa a.d., Risk Assessment on Workplace and in a Working Environment, 2019.
- [8] Mayer, R., Plank, C., Bohner, A., Kollarits, S., Corsini, A., Ronchetti, F. at all, MONITOR: Hazard monitoring for risk assessment and risk communication, *Georisk: Assessment and Management of Risk for Engineered Systems and Geohazards*, Vol. 2, pp. 195-222, 2008.
- [9] Moon, H.I., Shin, S., & Byeon, S.H. (2015). Exposure Monitoring and Health Risk Assessment of 1-Bromopropane as a Cleaning Solvent in the Workplace. *Human & Ecological Risk Assessment*, 21(3), 744–752.
- [10] Rajpradeesh, T., Venkumar, P., Hariraja, T., Nagarjun, J., & Manikandan, V. (2019). Hazard Identification on Cabtrim in Manufacturing Industry. *AIP Conference Proceedings*, 2128(1), 030004-1-030004-111.
- [11] Rout, B.K., Sikdar, B.K., Hazard Identification, Risk Assessment, and Control Measures as an Effective Tool of Occupational Health Assessment of Hazardous Process in an Iron Ore Pelletizing Industry, *Indian J Occup Environ Med.*, Vol. 21(2), pp. 56–76, 2017.

- [12] Shamsan A., Qasem, A.G., Development of Scoring Methodology for Ergonomic Risk Assessment in the Workplace, Proceedings of the 5th NA International Conference on Industrial Engineering and Operations Management, Detroit, Michigan, USA, August 10 - 14, ID 475. 2020.
- [13] Toffel, M. W., & Birkner, L. R. (2002). Estimating and Controlling Workplace Risk: An Approach for Occupational Hygiene and Safety Professionals. *Applied Occupational & Environmental Hygiene*, 17(7), 477–485.
- [14] Tupa, J., Simota J., Aspects of risk management implementation for Industry 4.0, *Procedia Manufacturing*, Vol.11, pp. 1223 – 1230, 2017.
- [15] Zaki, N.E.A.M, Rahman, M.N.A., Kamarudzaman, M., Ergonomic Risk Assessment Among Production Operators at Food Processing Industries: A Review, *Human Factors and Ergonomics Journal*, Vol.5(1), pp. 99 – 102, 2020.

GEOMETRIC CHARACTERISTICS OF PM PARTICLES TESTED WITH JMICROVISION SOFTWARE

Milana Ilić Mićunović¹, Zoran Čepić¹, Boris Agarski¹, Zorica Mirosavljević¹,
Željko Santoši¹

¹University of Novi Sad, Faculty of Technical Sciences, Novi Sad, Serbia

e-mail: milanai@uns.ac.rs

Abstract: Particulate matter (PM) the sum of all solid and liquid particles suspended in air, and one of the major problem of today. PM particles are often very hazardous and can cause serious damage to human health as well as other living beings, but also can cause damage to artificial systems. Proper sampling and measurement of all PM particle parameters is vital for their proper characterization. It is important to know their chemical as well as their physical characteristics.

In this study we sampled PM particle, using personal sampler. The particles was collected on a filter and then scanned with scanning electron microscopy (SEM). SEM micrographs are processed by the image analysis method with JMicroVision software. Proper settings and threshold limits are crucial for proper characterization of filter sample.

Key words: image processing, particles, JMicroVision software

INTRODUCTION

Air pollutants can be in form of gas or as aerosols, which include dust, fog, smog, smoke and fumes. Particles can be of natural and anthropogenic origin, and can be categorized as primary and secondary. Primary particles are released directly from natural and/or artificial sources, while secondary particles are formed by complex chemical reactions in the atmosphere [1].

Unlike most other pollutants that are classified on the basis of chemical composition, the most common division of particles is based on their size. This physical characteristic is important from the point of view of chemistry and physics, as well as health effects. According to the sizes of aerodynamic diameters, the particles are divided into the following fractions (Figure 1) [2]:

- Ultrafine fraction:
 - PM0.1 - particles smaller than 0.1 μm .
- Fine fractions:
 - PM1 - particles smaller than 1 μm .
 - PM2.5 - about 60% PM10, dimensions less than 2.5 μm
- Coarse fraction:
 - PM10 - particles smaller than 10 μm

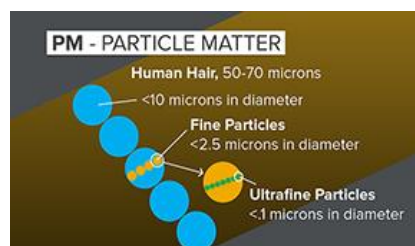

Fig. 1. Particulate matter (PM) size [3]

People are exposed to PM particles in the living and working environment. Inhalation of PM particles poses a risk to health that depends on their physical and chemical characteristics. To complete evaluation of particle exposure, it is very important to determine particles size and shape, as well as their chemical characteristics [4].

In this study we sampled PM particle, using personal sampler. The particles are collected on a filter and then we scanned particle size and shape with scanning electron microscopy (SEM). SEM micrographs are processed by the image analysis method.

The goal of this work is to define thresholds and problems of JMicroVision image processing software in the case of geometry determination of the particles collected on the filter.

IMAGE PROCESSING

The goal of image analysis is to provide a quantitative content description of the image and/or shape recognition, which is useful in the case that morphological characteristics of the object are related to its properties. The area of interest is visualized using a screen, and the system allows to select test area. With this system, it is possible to select the objects, as well as to separate, erase or merge adjacent particles. These systems allow image correction or the use of classification methods, such as image intensification by determining the shade of gray to obtain the best possible contrast.

Image analysis, as a method used to measure particle size, provides [5]:

- Satisfactory measurement accuracy;
- Fast calculations and automated analysis;
- Measurement of non-spherical particles over the longest and shortest diameters of projected area, or over the equivalent spherical diameter.

According to ISO 13322 (2014), the primary measurement includes the projected area of each particle expressed in pixels, followed by the longest and shortest diameter of each particle, also expressed in pixels. This method makes it easier to define the shape factors of particles with the highest discrimination. For these reasons, the recommended primary values would include: the area of each object, the longest and shortest dimension of each particle [6].

Problems that can occur during the quantitative characterization of particle shapes from micrographs can be attributed to the following factors [7]:

- Slowness of the particle collection process;
- Large amount of data obtained after particle collection;
- Diversity and complexity of particle shapes;
- Difficulties in defining factors suitable for modeling;
- Lack of classified methods for particle shape characterization;
- Need for a large sample, in order to achieve good statistical reliability of form information.

Reliance on standards in this area is of great importance for the proper implementation of the image analysis procedure and interpretation of results.

Determination of particle geometry by JMicroVision software

Determination of particle geometry is performed with the aim of their quantitative characterization. After processing the image using software, a set of geometric parameters is obtained that describe the size and shape of the particle. Using JMicroVision software, the characteristics of PM particles were determined by the following parameters:

Length is defined as the maximum distance (L) between any two points on the volume of the particle along the axis of orientation of the object and is parallel to the longest axis (Figure 2a). Length is most often expressed in μm .

Width represents the maximum distance (W) between any two points of particle perimeter along the axis of $+90^\circ$ object orientation and parallel to the shortest axis (Figure 2a). Width is most commonly expressed in μm [8, 9].

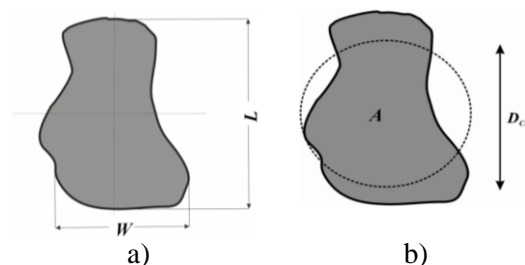

Fig.2. Size descriptors: a) Length (L) and width (W) of particles; b) Equivalent Circle Diameter [10]

Equivalent Circle Diameter is obtained by converting a 3D particle captured in a 2D image, into a circle equivalent to the surface of a 2D image (Figure 2b). The diameter of obtained circle is called the diameter of equivalent circle and is most often denoted by D_{CE} [11,12]. If we know area of particle A , the diameter of the equivalent circle can be calculated according to equation 1.1. The diameter of the equivalent circle is usually expressed in μm .

$$D_{CE} = \sqrt{\frac{4A}{\pi}} \quad (1.1)$$

Convexity CVX is a measure of particle surface roughness and is defined as the ratio of the volume of the convex hull and the volume of the 2D projection of the particle (Figure 3a). Convex hull of a set of points is determinate as the smallest convex polygon that contains all points. Convexity is calculated according to equation 1.2. It is dimensionless and can have values from 0 to 1. With rougher/more irregular the particle surface, volume of particle projection is higher, and the convexity is lower [13]. Smooth shapes have a convexity near 1, since the convex hull of the circle (ellipse) coincides with the contour. Irregularly shaped particles have a convexity less than 1, with increasing of shape irregularities, the closer the convexity is to zero.

$$CVX = \frac{P_{CH}}{P} \quad (1.2)$$

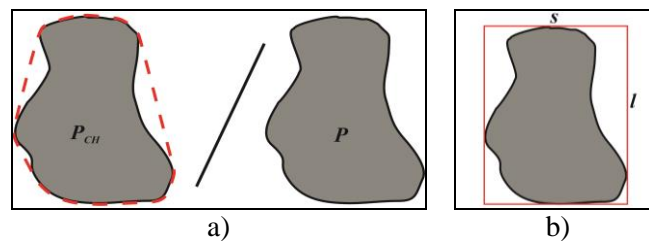

Fig. 3. Shape descriptors: a) convexity of particle; b) elongation of particle [10]

Elongation El is calculated according 1.3 where l is the length of the minimum boundary rectangle that includes the 2D projection of the particle, and s is the length of the shorter side (width) of the minimum boundary rectangle (Figure 3b). It is dimensionless and also can have values from 0 to 1 [13]. Shapes symmetrical in all axes, such as a circle or a square have an elongation value equal to 0, while asymmetrical shapes (elongated) have an elongation value closer to 1.

$$El = 1 - \frac{s}{l} \quad (1.3)$$

Compactness CP is defined as the ratio of the particle surface area (A) and the surface area of the circle (A_c) with the same volume (Figure 4a). Compactness is calculated according to equation 1.4 [14]. It is dimensionless and, with values from 0 to 1, more compact shapes have values close to 1.

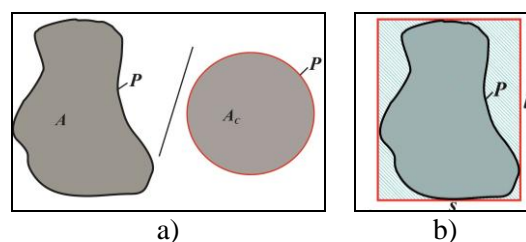

Fig. 4. Shape descriptors: a) compactness of particle; b) rectangularity of particle [10]

$$CP = \frac{A}{A_c} \quad (1.4)$$

Rectangularity RT is defined as the ratio of the volume of the 2D particle projection (P) and the volume of the minimum boundary rectangle, with length l and width s (Figure 4b), according to equation 1.5 [14]. Rectangle is a dimensionless. Values close to 1 indicate angular particles, while rounded particles have a value closer to 0.

$$RT = \frac{P}{2l + 2s} \quad (1.5)$$

Total irregularity of the particle shape depends on shape and the roughness of the particle that can vary independently. Surface roughness occurs in a certain range of scales (relative to particle size) and includes roughness based on the volume (texture) and based on the surface (morphology) of the particle. Shape parameters are generally sensitive to some of the following specific morphological properties [11, 15]:

Morphological roughness: compactness quantify the spatial distribution of the 2D particle projection surface. The surfaces of the 2D projection of the particle are compared with the surfaces of the boundary reference shapes, whether it is a boundary circle or a convex hull.

Textural roughness: convexity and rectangularity are a measure of textural roughness based on the perimeter of the object, again in relation to the boundary reference shape.

Form: elongation is focused on the relative difference between two particle dimensions, although the parameters differ how the particle dimensions are defined.

RESULTS AND TRESHOLDS SETTINGS

In order to obtain more information about the geometric characteristics of the particle and to select representative parameters, the SEM micrograph examination was performed in the image processing software JMicroVision.

In our case study we made a lot of images (micrographs) to cover as much of the filter surface. Reason for that is to reduce the risk of erroneous results. The same processes are applied to each image: (i) calibration (ii) normalized contrast improvement, (ii) application of filters to reduce background noise and (iii) limit settings to extract particles from the background. The basic stages of the particle image analysis process are shown in Figure 5.

Particle characterization by image analysis is a very reliable technique with many advantages. However, when accurate particle dimensions are required, the adjustment threshold becomes critical.

When measuring particle morphology, the recognition software must accurately identify where the particle boundaries are. When the threshold is set, pixels with brightness values outside that range are assigned to the background, after which the edges of the particles are defined. Various techniques have been developed for automatic threshold selection over shades of gray, however there is no universal threshold selection procedure that guarantees applicability to all images.

For this reason, for each micrograph, the threshold setting is set manually. One of the disadvantages of manually adjusting the threshold is subjectivity, so that the settings for each image are repeated several times. In this way, through a larger number of measurements, the possibility of error is reduced.

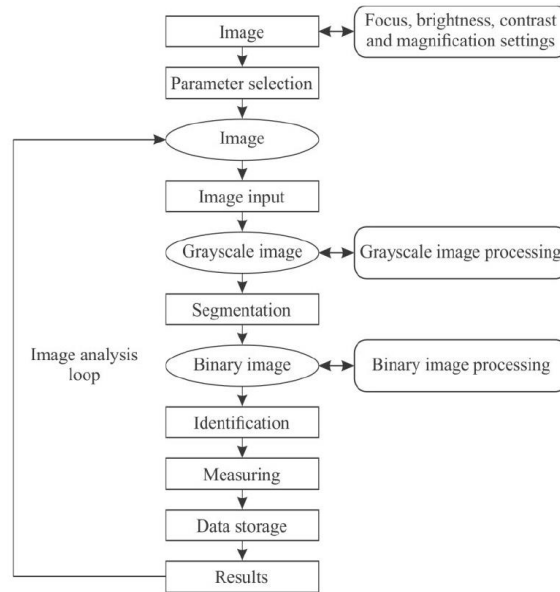

Fig. 5. Image analysis procedure flow chart

First settings is spatial calibration performed on the known length on SEM micrographs, by entering in the calibration menu a known distance (in micrometers).

This is followed by object extraction (*General description* > *Object extraction* > *Color or gray intensity threshold*). First of all, the surface of the image on which the particles are examined should be chosen, so that the accompanying information would not affect the results. The all-edge option allows the software to exclude particles on the edge from the calculation, in case they are not captured completely on the micrograph. Then the threshold intensity limit is set (Figure 6a), to a satisfactory level of selection (using the cursor, the color is added to the particle with the Add option. (Figure 6b).

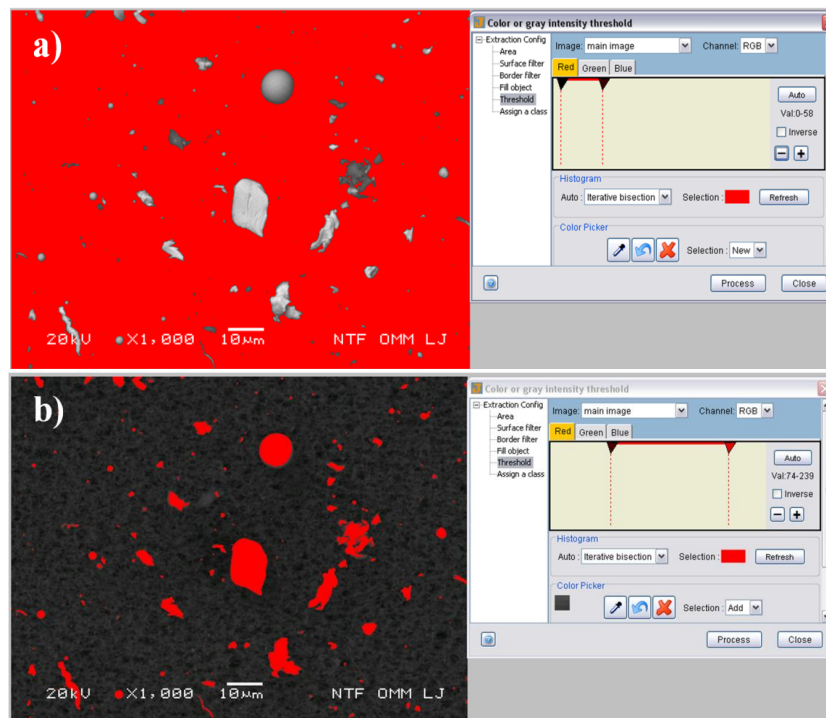

Fig. 6. Parameter settings in JMicroVision software: a) threshold settings; b) particle selection

JMicroVision, through the Image Factory option, provides the possibility of classical, nonlinear and gradient filtering. Classical or linear filtering, also known as the mathematical operation of convolution, involves multiplying a group of pixels of an input image with a series of pixels in a

convolutional kernel. The output value produced in a spatial convolutional operation is the weight average of each input pixel and adjacent pixels in the convolutional core. Linear filtering includes a large number of filters for fine processing, sharpening, reduction of background noise and edge filters (uniform, triangular, Gaussian, Wiener, etc.). Nonlinear filtering is based on the logical separation of filters into a series of relatively simple operations (median, minimum, maximum, and Kuwahara filter). Gradient filtering refers to the detection of edges by calculating the magnitude of the image gradient vector in two orthogonal directions.

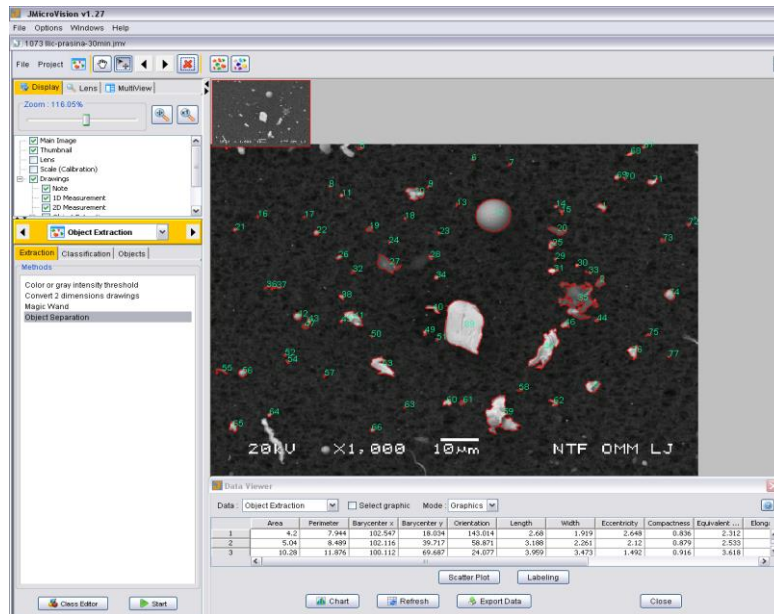

Fig. 7. Results in JMicroVision software

After setting all the necessary parameters in the software, the results are quantitative data that define the particle size - area, perimeter, equivalent circle diameter, length and width, as well as parameters that define the particle shape - elongation, compactness, rectangle, solidity, convexity and ellipticity (Figure 7).

CONCLUSION

Particle investigation method based on image analysis is not common and strongly depends on the way that sample is prepared for measurement, as well as on knowledge related to the samples basic physical and chemical properties. Proper adjustment of sensitive parameters during image processing is another major problem. On the one hand, a large number of image process particles are required for a statistically significant sample, and on the other hand, the thresholds setting and applied filter very much depends on the sample itself and the position of the particle. In this paper, some of the settings on the JMicroVision image processing software are presented, and a semi-automatic sample analysis is adopted.

REFERENCES

- [1] EPA Indoor Air Quality, EPA's Report on the Environment (ROE), United States Environmental Protection Agency, U.S., 2017.
- [2] ISO 7708 : Air quality - Particle size fraction definitions for health-related sampling, International Organization for Standardization, 1995.
- [3] Department of Environmental Conservation, New York:
<https://www.dec.ny.gov/chemical/8539.html> (accessed 10/9/2020)
- [4] Qian, S., Jiang, M., Liu, Y.: Inertial migration of aerosol particles in three-dimensional microfluidic channels, *Particuology*, 2020.

- [5] Mazzoli, A., Favoni, O.: Particle size, size distribution and morphological evaluation of airborne dust particles of diverse woods by Scanning Electron Microscopy and image processing program, *Powder Technology*, Vol. 225, pp. 65–71., 2012,
- [6] ISO 13322-1: Particle size analysis -- Image analysis methods -- Part 1: Static image analysis methods, International Standardization Organization, 2014.
- [7] Lin, C.L., Miller, J.D.: 3D characterization and analysis of particle shape using X-ray microtomography (XMT), *Powder Technology*, Vol. 154, pp. 61–69., 2005.
- [8] Olson E.: Particle shape factors and their use in image analysis – part 1: theory, *Journal of GxP Compliance*, Vol. 15, No 3, pp. 85-96., 2011.
- [9] Wu J., Peng Z.: Investigation of the geometries and surface topographies of UHMWPE wear particles, *Tribology International*, 2013, Vol. 66, pp. 208–218.
- [10] Ilić Mićunović, M.: Model za evaluaciju rezultata merenja karakteristika praškastih materija zasnovan na elektronskoj mikroskopiji, doktorska disertacija Novi Sad, Fakultet tehničkih nauka u Novom Sadu, 2018.
- [11] Liu, E.J., Cashman, K.V., Rust, A.C.: Optimising shape analysis to quantify volcanic ash morphology, *GeoResJ*, Vol. 8, pp. 14–30., 2015.
- [12] Bagheri, G.H., Bonadonna, C., Manzella, I., Vonlanthen, P.: On the characterization of size and shape of irregular particles, *Powder Technology*, Vol. 270, Part A, pp. 141–153., 2015.
- [13] Heilbronner, R., Barrett, S.: *Image analysis in earth sciences: microstructure and textures of earth materials*, Springer, 2014, ISBN 978-3-642-10343-8.
- [14] Jordan, S.C., Dürig, T., Cas, R.A.F., Zimanowski, B.: Processes controlling the shape of ash particles: Results of statistical IPA, *Journal of Volcanology and Geothermal Research*, Vol. 288, pp. 19-27., 2014.
- [15] Leibrandt, S., Le Pennec, J.L.: Towards fast and routine analyses of volcanic ash morphometry for eruption surveillance applications, *Journal of Volcanology and Geothermal Research*, Vol. 297, pp. 11-27., 2015.

THE EFFECTS OF ECONOMIC TRENDS AND SAFETY REGULATIONS ON OCCUPATIONAL INJURIES

Goran Janačković¹, Ivan Radojković², Amelija Đorđević¹,
Jasmina Radosavljević¹, Dejan Vasović¹

¹University of Niš, Faculty of Occupational Safety, Niš, Serbia

²Dunav Voluntary Pension Fund Management Company, Serbia

e-mail: goran.janackovic@zrfak.ni.ac.rs

Abstract: For the purposes of this paper, data on the economic activity of EU countries, the number of employees and accidents were used. These values are analysed in the context of recent economic crises that have occurred worldwide, and the effects of these crises on representative safety performance indicators. Relative change of indicators in relation to previous year was analysed. The effects of risk regulations were also taken into consideration. The complexity of the safety system causes the connection between economic activities, and the number of injuries at work and fatalities is not as simple as it may seem at first glance. It is caused by complex connections among the different actors in the safety system.

Key words: occupational injuries, safety regulations, safety system

INTRODUCTION

The development of civilization has been supported by various technological innovations. We are witnessing constant improvement of industrial facilities. These innovations have led to a remarkable increase in production volume and quality of final products. Also, people are increasingly excluded from the production processes and involved in the monitoring and control processes. It was necessary to introduce innovative solutions in technological processes that significantly improved productivity and other parameters of the production process, and completely new energy sources.

Economic aspects, efficiency and effectiveness, increase in the production volume and cheaper final products in economies of scale, with rational use of available energy represent only one side of industrial development. Industrial development must be accompanied by appropriate research into the adverse effects of new technologies on employees and the environment. The level of protection of workers becomes very important for social acceptability of further development. Even in the developed countries, the number of injuries at work and occupational diseases can be very high.

A large number of employees with occupational diseases and injuries can be a significant burden for any society. Therefore, the consequences on human health and adequate safety measures must be analysed at all stages of the development of new technologies. Only in this way the introduction of new technologies can be considered as an improvement of society comparable to previous industrial revolutions, because it should be more oriented towards sustainable development of civilization and improving the environment, significantly degraded by irrational use of natural resources which has accelerated the development of civilization during the previous industrial revolutions.

MATERIAL AND METHODS

Development of safety approaches

There is growing concern about adverse effects of various innovations on humans and the environment (pollution, health and psychological problems, the impact on tissues and processes in living beings) [1]. People are particularly concerned about the fact that less and less attention is paid to health issues during the research of new technologies, especially when the development cycle is so small (1.5 to 2 years), and it is not possible to identify convincing results about any long-term side effects. Typical example is the 5G technology and adverse health effects, where insufficient research about the impact leads to human concerns and various incomplete analyses and theories [2].

The development of the safety system is also important [3]. Only when the safety system stakeholders began to look forward to remove the causes of injuries and occupational diseases, it began to

contribute to rapid improvement of working conditions. Workers' mistakes have ceased to be the only cause of injuries and deaths, incidents have been identified, inspections have been introduced and working conditions monitored. The introduction of the safety management system was the next big step, which improved working conditions, especially in large and complex organizational systems. Its integration leads to more efficient use of available organizational resources, and standardization achieves the establishment of systems with characteristics comparable to other systems, which provides simpler benchmarking performance and identification of key indicators for improving the existing system [4, 5]. Thus defined integrated systems enable simpler exchange of experiences and cooperation in the organization and between connected organizations, so that similar successful solutions can be applied in practice [6].

Safety performance and regulations

The analysis of the success of the protection system as a complex socio-technical system can be considered using direct and indirect indicators [7, 8]. One of basic direct indicators is the number of injuries or fatalities [9, 10]. Direct indicators describe the outcomes, i.e. the results of the system's success, while indirect indicators describe the quality of certain organizational activities that prevent the occurrence of adverse events or outcomes. In this paper, representative direct indicators available in the Eurostat database and statistical methods of analysis of available data are applied.

Safety was considered as additional cost, and lack of funds was the main excuse to avoid applying certain safety measures. Economic aspects are very important in business, especially with small and medium enterprises that have limited resources at their disposal. Thus, indirectly, economic cycles and crises can significantly affect safety performance, expressed through the number of work-related injuries and deaths [11, 12, 13]. The total number of workers, activity in certain industries, as well as investments in production and safety system can be analysed in the context of organizational system change.

RESULTS

The economic aspects of analysed countries were considered for the period 2007-2019. A particularly critical period for a large number of EU countries was 2008-2009, while the consequences in some small countries were felt until 2011. The year 2012 was also problematic. In Serbia, 2014 was particularly critical due to floods. The GDP trends in the EU and Serbia for the period 2007 to 2019 are shown in Table 1. As starting year, the 2007 was taken, just before the financial crisis. The table shows the relative trends of GDP for each year compared to the previous year.

Table 1. GDP trends in the EU28 and Serbia (according to Eurostat)

	2007	2008	2009	2010	2011	2012	2013	2014	2015	2016	2017	2018	2019
EU28	26,230	0.1%	-4.6%	1.9%	1.6%	-0.7%	0.1%	1.5%	2.0%	1.7%	2.4%	1.7%	1.2%
RS	4,130	6.1%	-2.3%	1.2%	2.8%	-0.2%	3.4%	-1.1%	2.2%	3.9%	2.7%	4.8%	4.6%

The situation on world markets has significantly influenced the changing trends in all countries, regardless of their development. Particularly large variations were in the new EU members. Economic trends significantly affected economic activity and engaged labour force. Relative change in the number of employees in the EU28, based on data available in the Eurostat database and the data presented by the Statistical office of the Republic of Serbia, is shown in Table 2. The data were available for the period 2008 to 2019.

In many economies, this affected change in the number of injuries (Table 3), as well as fatalities (Table 4). In highly developed countries (HDC), the variations were generally smaller, while in medium income countries these variations were larger.

Table 2. Relative change in the number of employees in the EU and Serbia (according to Eurostat and the Statistical office of the Republic of Serbia)

	2008	2009	2010	2011	2012	2013	2014	2015	2016	2017	2018	2019
EU28	230997.33	-1.77%	-0.79%	0.05%	-0.11%	-0.22%	1.06%	1.11%	1.27%	1.56%	1.35%	1.03%
RS	2821.72	-7.27%	-8.42%	-9.58%	-1.11%	2.59%	16.43%	0.58%	5.64%	2.77%	1.37%	2.40%

Table 3. Relative change in the number of injuries (4 days or over) in the EU28 countries (according to Eurostat)

	2009	2010	2011	2012	2013	2014	2015	2016	2017
EU28	1890	0.4%	-1.4%	-8.3%	-1.0%	-2.3%	-1.1%	0.2%	1.2%
BE	2038.44	1.6%	21.8%	-12.9%	-2.3%	-19.7%	-11.9%	29.9%	-1.3%
BG	86.15	-1.1%	-0.7%	0.3%	-6.1%	3.5%	0.4%	-8.2%	3.9%
CZ	1469.84	-11.5%	-25.3%	-3.1%	-4.8%	1.2%	5.1%	-3.8%	-3.6%
DK	2135.56	10.0%	-4.7%	-2.7%	-3.8%	-5.3%	-9.8%	1.4%	-11.0%
DE	2088.88	6.6%	6.4%	-7.0%	-1.1%	-2.5%	-1.3%	-0.8%	-1.0%
EE	1045.47	18.2%	-12.9%	-6.6%	8.9%	3.9%	5.8%	0.5%	-13.2%
IE	582.31	62.8%	0.7%	-15.2%	28.0%	3.5%	-13.8%	-16.8%	45.1%
EL	642.71	-17.5%	-2.2%	-11.5%	-2.7%	-66.0%	58.7%	-5.1%	3.2%
ES	3867.27	-8.0%	-3.8%	-15.6%	0.7%	10.7%	-2.2%	1.9%	1.8%
FR	2848.13	15.1%	39.7%	-33.4%	3.8%	7.0%	3.1%	-2.3%	-3.0%
HR	901	-5.3%	18.7%	-17.4%	3.8%	4.4%	9.1%	-0.5%	6.1%
IT	2332.79	-4.5%	-10.1%	-16.1%	1.7%	-5.4%	-6.4%	-2.5%	-1.4%
CY	765.96	-1.1%	13.3%	-12.1%	-24.3%	52.3%	-19.9%	2.8%	4.8%
LV	126.97	9.6%	40.6%	-0.5%	15.4%	-0.8%	11.3%	-4.9%	4.5%
LT	210.32	-0.5%	12.4%	19.1%	-7.3%	14.3%	5.8%	6.0%	13.3%
LU	2314.31	2.6%	0.9%	-3.0%	6.1%	-7.3%	-1.4%	11.3%	-15.1%
HU	505.85	8.0%	-2.8%	0.6%	-8.8%	12.7%	3.7%	26.9%	-11.4%
MT	2172.98	-4.2%	-11.2%	8.7%	-6.0%	-1.3%	-10.1%	-10.0%	-29.8%
NL	2192.86	7.7%	-4.0%	17.4%	-14.5%	-38.8%	-10.9%	5.1%	11.3%
AT	2254.24	-4.9%	-8.5%	-3.0%	-3.3%	-1.9%	-3.1%	20.1%	-1.4%
PL	1040.43	-33.3%	-16.3%	4.5%	-10.9%	-2.9%	1.9%	0.5%	-3.6%
PT	3535.41	-4.4%	4.6%	0.7%	1.6%	-1.0%	2.7%	-2.4%	-0.7%
RO	47.93	41.5%	10.2%	-3.0%	5.8%	-2.5%	14.7%	1.8%	5.1%
SI	1805.59	9.9%	1.1%	-10.9%	-10.8%	2.0%	1.9%	-6.2%	5.1%
SK	447.08	16.4%	-14.5%	-5.3%	1.3%	-2.8%	26.7%	1.4%	-0.5%
FI	2074.78	3.3%	15.7%	-12.7%	2.9%	-6.6%	-5.7%	-5.3%	2.5%
SE	826.87	7.5%	-1.6%	3.1%	-2.9%	-13.2%	1.2%	3.6%	-2.7%
UK	1067.41	-3.4%	-1.0%	-12.4%	10.6%	2.6%	-9.6%	-5.8%	-2.7%

Table 4. Relative change in the number of fatalities in the EU28 according to Eurostat (average value)

	2009	2010	2011	2012	2013	2014	2015	2016	2017
EU28	2.56	3.9%	-4.5%	-4.7%	-6.6%	3.1%	2.6%	-10.0%	-1.4%

Figure 1 shows the number of fatal injuries in the EU, based on Eurostat data for individual countries in 2017. The Netherlands has very low number of injuries per 100,000 employees. The Scandinavian countries, the United Kingdom and Germany also have fewer injuries per 100,000 employees compared to the other EU countries. The data for the Kosovo and Metohija, according to the Resolution SC UN 1244, are not included into the statistics for Serbia.

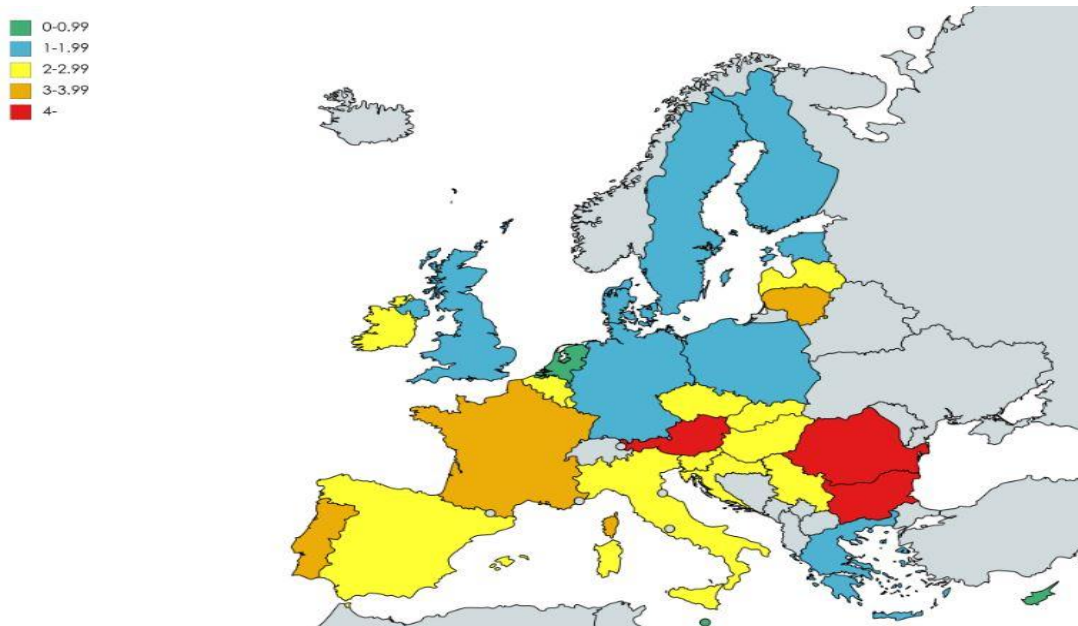

Fig. 1. Fatal injuries in Europe in 2017 (the mapchart based on Eurostat database); Kosovo and Metohija are presented according to the Resolution SC UN 1244

The inequality in the number of injuries and fatalities is noticeable, so it is necessary to make additional efforts to find the cause.

DISCUSSION

During the analysis of direct indicators describing the efficiency of the safety system at the country level, one should keep in mind the size of the country and the specifics of industrial development. Although the most developed countries usually have heavy industry as a basis, modern trends are increasingly directed towards service sector, while multinational corporations locate industrial facilities in countries with location and resource advantages. This can reduce the number of fatal injuries in their home countries.

Economic slowdown can indirectly affect the deterioration in the safety system, as it can lead to a decrease in the allocation of funds available for protection, and thus an increase in the number of injuries or occupational diseases [11]. On the other hand, the decline in industrial activity caused by the economic crisis may seemingly mask the absolute increase in the number of injuries. Therefore, the analysis cannot be simple, and requires additional performance indicators.

The most developed economies are usually characterized by a reduction in the number of injuries at work due to increased investment in the safety system, increased automation of industrial systems and greater system standardization. Starting from the economic crisis of 2008, more and more authors point out the correlation between the economic cycle and occupation accidents, whereby in certain countries the reduction of economic activity significantly leads to a reduction in the occurrence of accidents, which emphasizes that the number of incidents is in correlation with changes in the number of employees [11, 14]. This supports the view that the increase in the number of workers in certain key sectors with the highest number of injuries and deaths has not been accompanied by corresponding improvement in the safety system.

The development of the safety system can be monitored on the basis of changes in economic activity. If the activities are caused by changes in economic activity, which is characteristic of less developed countries, the increase in economic activity is not accompanied by a corresponding improvement in the safety system. This would overturn the development to the detriment of protection. This is not characteristic of HDCs, in which a strict legislative system and strong professional associations do not allow the development of the economy not to be accompanied by the improvement of the safety system.

In [15], the authors emphasize the importance of regulation on the outcomes of the safety system. Professional associations and insurance associations are in most developed countries a source of methods for risk assessment and identification of potential dangers. The legislative systems represent specificity in the governance system. As pointed out in [15], the coordination of different actors in the safety management system and their complementarity significantly affects the specifics of the safety system at national level. In this case, countries with longer tradition of safety legislation have an advantage compared to the other countries.

CONCLUSION

Economies based on the service sector are more susceptible to greater variations in the number of employees, which causes the variations in the number of injuries at work and occupational diseases. Traditionally, developed economies have better withstood economic shocks, due to greater diversification of the economy and the possibility of easier access to larger markets. If the number of injuries and fatalities is directly proportional to the number of employees, it means that there are no significant changes in the safety system. This means that the increase in the number of workers is not accompanied by the improvement of the safety system, which causes an increase in the number of negative outcomes. Strict legislation and adherence to work procedures affect good results in the safety system. The complexity of the safety system causes that the connection between economic activities and the number of injuries at work and fatalities is not as simple as it may seem at first glance. It is caused by complex connections in the safety system and the influence of organizational and economic factors on that system.

ACKNOWLEDGMENT

The research is done under the auspices of the Ministry of Education and Science, Republic of Serbia.

REFERENCES

- [1] Similä, J., Pollution regulation and its effects on technological innovations, *Journal of Environmental Law*, vol. 14, no. 2, pp. 143-160, 2002.
- [2] Kostoff, R.N., Heroux, P., Aschner, M., Tsatsakis, A., Adverse health effects of 5G mobile networking technology under real-life conditions, *Toxicology Letters*, vol. 323, pp. 35-40, 2020.
- [3] Janačković, G., Evaluation of safety approaches in small and medium enterprises by means of Analytic Network Process, in *Proc. of the 1st V. Multidisciplinary conference QUAESTI, Zilina, Slovakia, 16-20. December*, pp. 29-35, 2013.
- [4] Janačković, G., Factors influencing efficient integration of safety systems, in *Proc. of the V. conference Human and social sciences at the common conference, Slovakia, 13-17, 2013*.
- [5] Janačković, G., Stojiljković, E., Grozdanović, M., Selection of key indicators for the improvement of occupational safety system in electricity distribution companies, *Safety Science*, vol. 125, pp. 1-7, 2020.
- [6] Janačković, G., Vasović, D., Mušicki, S., Ranking key performance indicators of collaboration in integrated safety systems, in *Proc. of the IV International Symposium Engineering Management and Competitiveness (EMC 2014), Zrenjanin*, pp. 466-471, 2014.
- [7] Walker, G.H., Stanton, N.A., Salmon, P.M., Jenkins, D.P., A review of sociotechnical systems theory: A classic concept for new command and control paradigms, *Theoretical issues in ergonomics science*, Vol. 9, No.6, pp. 479-499, 2008.
- [8] Janackovic, G., Savic, S., Stankovic, M., Selection and ranking of occupational safety indicators based on fuzzy AHP: case study in road construction companies, *The South African journal of industrial engineering*, col. 24, no. 3, pp. 175-189, 2013.
- [9] Benavides, F.G., Benach, J., Martinez, J.M., Gonzalez, S., Description of fatal occupational injury rates in five selected European Union countries: Austria, Finland, France, Spain and Sweden, *Safety science*, vol. 43, pp. 497-502, 2005.

- [10] Broszkiewicz, R., Affluence, occupational safety and ergonomics: are they interdependent, *International journal of occupational safety and ergonomics*, vol. 22, no. 4, pp. 577-579, 2016.
- [11] Barth, A., Winker, R., Ponocny-Seliger, E., Sögner, L., Economic growth and the incidence of occupational injuries in Austria, *Wiener Klinische Wochenschrift*, vol. 119, no. 5-6, pp. 158-163, 2007.
- [12] Kahraman, E., Akay, Ö., Kılıç, A.M., Investigation into the relationship between fatal work accidents, national income, and employment rate in developed and developing countries, *Journal of occupational health*, vol. 61, pp. 213-218, 2018.
- [13] Mouza, A.M., Targoutzidis, A., The effect of the economic cycle on workplace accidents in six european countries, *Ege Academic Review*, vol. 10, no. 1, pp. 1-13, 2010.
- [14] Fernández-Muñiz, B., Montes-Peón, J.M., Vázquez-Ordás, C.J., Occupational accidents and the economic cycle in Spain 1994–2014, *Safety science*, vol. 106, pp. 273-284, 2018.
- [15] Rothstein H., Demeritt D., Paul R., Beaussier A.-L., Wesseling M., Howard M., de Haan M., Borraz O., Huber M. and Boudier F., Varieties of risk regulation in Europe: coordination, complementarity and occupational safety in capitalist welfare states, *Socio-Economic Review*, Vol. 17, No. 4, 993-1020, 2019.

PRELIMINARY DESIGN CALCULATIONS OF A SMALL WIND GENERATOR FOR THE SURROUNDINGS OF TOWN OF ZRENJANIN

Dimitar Petrov¹

¹Technical University of Sofia – branch Plovdiv, Faculty of Mechanical Engineering,
Plovdiv, Bulgaria

e-mail: dimgog@tu-plovdiv.bg

Abstract: Example calculations of a small wind turbine for selected electricity needs is presented. Based on some data about the wind conditions for the surrounding of the town of Zrenjanin and the required energy consumption for an individual consumer, the required electric power output of the wind generator, the average wind speed at the turbine level, the radius of the propeller and the rated speed of rotation are determined. The results of determining some basic parameters of the wind generator blade are also given. Some characteristics of the wind generator are presented.

Key words: wind turbine, wind energy, design calculations, tip speed ratio

INTRODUCTION

The unstable fuel prices and of the energy resources in general, the problems related to the environmental pollution such as the release of harmful or toxic gases, the greenhouse effect, the total thermal pollution, etc. suggest the search for alternative "green" energy sources. Efforts to generate green energy may include a system of measures to use "free" energy sources, such as wind energy and solar energy by each individual consumer. The use of wind energy has been around for thousands of years, but it is currently very topical.

In Serbia, there has been an increasing interest in the use of this type of energy in recent years, which is why the amount of scientific publications on the issue is increasing.

The present work is an attempt to make a modest contribution to its enrichment together with the references to other sources of technical literature.

METHOD OF THE CONSTRUCTIVE CALCULATIONS - AN EXAMPLE SEQUENCE

Assessment of energy needs

According to power wind generators can be divided into [1]: micro (50-250 W); small (250 W-1 kW); domestic (1-50 kW); medium (50-750 kW) and large (> 750 kW). Small-power wind generators do not, in principle, serve as a single source of energy, but rather to support energy needs, for example in single-family homes. Energy-intensive needs such as heating, cooking, hot water, production activities are provided by other sources - electricity, gas, timber and / or solar energy. Only the most basic for a comfortable and normal life of household appliances, such as lighting, TV, refrigerator, computer, etc., are powered by a wind generator. The power supply from a wind generator is shown in Figure 1.

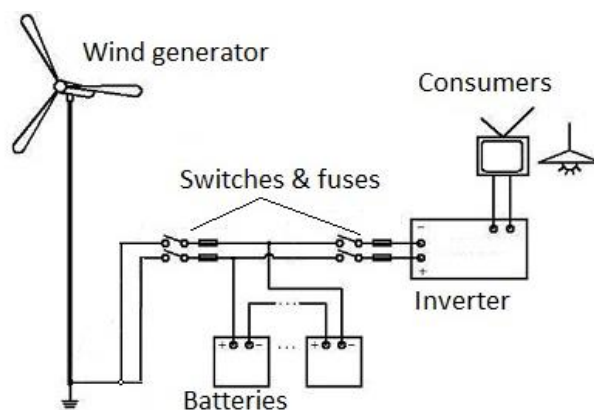

Fig. 1. Wind turbine system

When there is sufficient wind flow, rechargeable batteries are charged (for example, 12 V, 60 Ah capacity connected in parallel). With consumers connected (TV, lamps, etc.), the DC 12 V voltage from the batteries is converted to AC 220 V via an inverter. As a first step in the preliminary calculations, an approximate estimate is made of the required power P and energy E , which should be met by the wind generator system [2]. Table 1 shows an example distribution of power and power consumption by electricity consumers over a period of one week.

Table 1. Distribution of power and power consumption by electricity consumers in a home.

AC Consumers	Power	Hours per	Days of work	Energy
	P_i , [W]	day, h_i , [h]	in a week, n_i	E_{w_i} , [Wh]
LED Lighting – bath	8	1,0	7,0	56
LED Lighting – Kitchen	15	2,5	7,0	262,5
LED Lighting – Bedroom	9	1,5	7,0	94,5
LED Lighting – Living room	32	4,0	7,0	896
TV	50	3,0	7,0	1050
Refrigerator	20	24,0	7,0	3360
Washing machine	500	1,5	2,0	1500
Laptop	20	4,0	7,0	560
Total	$P = 654$			$E_{WEEK} = 7779$

The maximal instantaneous power of the consumers is:

$$P = \sum P_i = 8 + 15 + 9 + 32 + 50 + 20 + 500 + 20 = 654 \text{ W} \quad (1)$$

The energy that consumers need in a week is:

$$E_{WEEK} = \sum P_i h_i n_i = 8 \times 1 \times 7 + 15 \times 2,5 \times 7 + \dots + 500 \times 1,5 \times 2 + 20 \times 4 \times 7 = 7779 \text{ Wh} \quad (2)$$

Some of the calculations below are given according to the methodology used in the EnergyBudgetWorksheet.xls file, which can be downloaded from [2]. The $E_{W,GEN}$ energy produced by the wind turbine for one week when using the AC users, due to the conversion efficiency from the wind turbine to the users is greater than E_{WEEK} and is calculated by the formula (k_E - loss factor; $k_E = 1.3$ for AC users; $k_E = 1.2$ for DC users):

$$E_{W,GEN} = k_E \times E_{WEEK} = 1.3 \times E_{WEEK} = 1.3 \times 7779 = 10113 \text{ Wh} \quad (3)$$

Then in one day the wind generator must provide:

$$E_{D,GEN} = E_{W,GEN} / 7 = 10113 / 7 \approx 1445 \text{ Wh} \quad (4)$$

At this point, it is advisable to calculate the required number of $N_{R,BAT}$ rechargeable batteries:

$$N_{R,BAT} = INT\{[(E_{D,GEN}) \times (N_{D,AUTO})] / [(V_{NOM}) \times (D_{P,D}) \times (C_{NOM,B})] + 1\} \quad (5)$$

, where $N_{D,AUTO}$ - number of days of autonomous operation of the system ($N_{D,AUTO} = 3.5$ days recommended), V_{NOM} - nominal voltage of the batteries and inverter used in the system (let $V_{NOM} = 12$ V), $D_{P,D}$ - permissible degree of discharge of the batteries (let $D_{P,D} = 75\% = 0.75$), $C_{NOM,B}$ - nominal capacity of the batteries (let $C_{NOM,B} = 125$ Ah, see [3]), INT - INTEGER function giving the largest integer less than the value of the argument. Then:

$$N_{R,BAT} = INT\{[(1445) \times (3,5)] / [(12) \times (0,75) \times (125)] + 1\} = 5 \quad (6)$$

Determination of the required rated power of the wind generator

Here, the required power of the wind generator must be matched to the specific wind energy resource at the location where it will be installed. It is recommended that a so-called wind audit be prepared [5], taking into account such factors as the altitude of the wind generator, the density of the wind, the wind speed, the micro-relief of the surroundings, the geographical location (by the sea, in the mountains, etc.), influence of surface roughness [6]. Summarized the wind resource statistics for the area may also be used for an estimate. It is best to have specific measured values of wind speed and air density at the location of the wind turbine installation and the intended altitude of the wind turbine. The formula (7) from [12] for determining wind power could also be used to determine the average wind speed at the intended installation site .

$$W = (1/2) \times \rho \times A \times v^3 \quad (7)$$

where: ρ - wind density (It depends on barometric pressure and temperature. As the altitude and temperature increase, the air density decreases. In [9], the necessary dependencies are given by which it can be calculated ρ depending on the temperature and barometric pressure), A is the swept area of the blade, and v is the wind speed.

According to sources [4], [5], [6] in the vicinity of town of Zrenjanin (elevation above sea level 76 m) in Vojvodina, at an altitude of 100 m, the average annual wind speed is about 5 ÷ 6 m/s and the average wind power flow is about 180 W/m² (250 according [6]). Let accept the value of average wind power flow at elevation of 100 m to be $P_p = 180 \text{ W/m}^2$. The density ρ of air at total elevation $z = 176 \text{ m}$ could be calculated [13] by formula (8):

$$\rho = \rho_0 \left(1 + \frac{cz}{T_0} \right)^{-\left(\frac{g}{cR} + 1 \right)} \quad (8)$$

Where: $\rho_0 = 1,204 \text{ kg/m}^3$ [8] is air density at sea level and $p = 100 \text{ kPa}$ at 20 °C; $z = 176 \text{ m}$ – altitude; $c = dT/dz = 0,006$ [9],[10],[11] - temperature gradient with respect to altitude; R - the gas constant [7] and $R = 287 \text{ J/kg-K}$ for air; $g = 9,81 \text{ m/s}^2$; and. Then:

$$\rho = 1,204 \times \left(1 + \frac{0.006 \times 176}{293.15} \right)^{-\left(\frac{9.81}{0.006 \times 287} + 1 \right)} = 1,174, \text{ kg/m}^3 \quad (9)$$

Thus, for the average wind speed for the Zrenjanin region at an altitude of 100 m, we obtain:

$$v_0 = \sqrt[3]{\frac{2(W/A)}{\rho}} = \sqrt[3]{\frac{2(P_p)}{\rho}} = \sqrt[3]{\frac{2 \times (180)}{1.174}} = 6.74 \text{ m/s} \quad (10)$$

Since the wind generator is most likely to be located at an altitude h other than the height above the earth $h_0 = 100 \text{ m}$ for which there are data on wind characteristics, the law of changing the wind speed in altitude could be used [14], [15]:

$$\frac{v}{v_0} = \left(\frac{h}{h_0} \right)^a \quad (11)$$

where: v_0 and h_0 are the known values of wind speed in m/s and given height above earth in m; h - planned generator height above earth in m (let $h = 10 \text{ m}$ for a small house or villa); v - demanded wind speed at new height (m/s); a is an empirical exponent: $a = 0,1$ for wide flat or water surfaces

surroundings, $a = 0,2$ in the presence of separate high groups of facilities in the vicinity, $a = 0,4$ in the city center of tall buildings [15]. For Zrenjanin vicinities $a = 0,1$. Then from (11):

$$v = v_0 \left(\frac{h}{h_0} \right)^a = 6.74 \times \left(\frac{10}{100} \right)^{0.1} = 5.357 \text{ m/s} \quad (12)$$

Assuming the useful part of the winds [16] is the one with speeds in the useful range of 4.5 to 11.5 m/s, then for an average wind speed of 5 m/s, the percentage of time during which the winds have not too little speed or neither too big is about 70% [16] of total time during a day:

$$(Time\ Useful) = (Total\ Time) \times (Percent\ of\ Useful\ Time) = (24) \times (0.7) = 16.8 \text{ hours} \quad (13)$$

Then, for those 16.80 hours, more than $E_{D,GEN} = 1444,7$ Wh must be generated, i.e. it should be looked for a wind generator with an approximate rated power greater than:

$$P = E_{D,GEN} / (Time\ Useful) = 1444,7 / 16,8 = 86,5 \text{ W} \quad (14)$$

So, it could be accepted rated power of 100 W for this wind generator.

$$P = 100 \text{ W} \quad (15)$$

Tip speed ratio, output power, radius of the rotor of a wind generator

In order to determine these parameters, it must be made clear in advance about the choice of type of wind generator, the rated rotational speed of the power generator, and so-called tip speed ratio $TSR = \lambda$. Generally wind generators are divided into vertical axial and horizontal axial ones. Those with a vertical axis have the advantage that they do not need to be directed in the wind direction, but in principle have a lower efficiency. That is why horizontal axes are now used, which are fast-moving (with one, two and three blades) and slow-moving (with more blades). The tip speed ratio λ is a basic parameter of the rotor of a wind generator that depends on its design (mainly the number of blades B of the blade) and is equal to the ratio of the peripheral speed of the blade end to the wind speed [17].

$$\lambda = \frac{\omega R}{v} \quad (16)$$

, where ω is the angular velocity of the blade in rad/s, R - radius of the blade (of the swept area) in m, v - wind speed in m/s. Empirical data for the optimal value of tip speed ratio λ_{opt} are given in a number of sources [17], [18]. For example, in [17], these values are recommended - for a rotor with 1 blade $\lambda_{opt} = 9$; with 2 blades - $\lambda_{opt} = 7$; with 3 blades - $\lambda_{opt} = 5$; with 6 blades - $\lambda_{opt} = 3$; with 12 blades - $\lambda_{opt} = 1,2$. In [7] is recommended that a wind turbine with three blades would have an optimal tip speed ratio calculated by formula:

$$\lambda_{opt} = (1,25 \dots 1,30) (4\pi/3) \approx (1.275) \times (4 \times \pi / 3) = 5,341 \quad (17)$$

To determine the required radius of the rotor, the equation for calculating the power output of the wind generator can be used [7]:

$$P = (1/2) \rho_{10} (\pi R^2) v^3 C_P \eta_G \eta_M \quad (18)$$

, where P is the output power in W of wind rotor (here $P = 100$ W); ρ_{10} - air density at 10 m above earth surface ($\rho_{10} = 1.188 \text{ kg/m}^3$ see formula (9)); (πR^2) - swept blade area (m^2); v - wind speed in m/s at 10 m above earth surface (here $v = 5,357 \text{ m/s}$); C_P - power coefficient (wind energy utilization

coefficient). The maximum theoretical C_P value is 0.593. For the best high-speed wheels: $C_P = 0.42 \sim 0.46$. For multi-blade slow-speed wind wheels: $C_P = 0.27 \sim 0.35$. Let $C_P = 0.42$; η_M - efficiency of the mechanical and gear-motor matching gear - multiplier (if used $\eta_M = 0.7 \sim 0.9$; if not used it $\eta_M = 1$) Let $\eta_M = 0.9$; η_G is the efficiency of the generator (automobile - 0.6, of permanent magnets - 0.8) (here the generator [19] is of permanent magnets and $\eta_G = 0.8$). Then from (18) it follows:

$$R = \sqrt{(2P)/(\rho_{10} \cdot \pi \cdot v^3 \cdot C_P \cdot \eta_G \cdot \eta_M)} = \sqrt{(2 \times 100)/(1.188 \times \pi \times 5.357^3 \times 0.42 \times 0.8 \times 0.9)} = 1.074 \text{ m} \quad (19)$$

From (16) for the rated rotational speed at $v = 5,357 \text{ m/s}$ it is obtained:

$$\omega = (\lambda_{opt} \cdot v)/R = (5.341 \times 5.357)/1.074 = 26.65 \text{ rad / s} \quad (20)$$

DETERMINATION OF SOME AERODYNAMIC AND POWER CHARACTERISTICS.

The blade profiling involves determining the distribution of the angles of cross-sections placement, the distribution of the lengths of the chords of the sections, and also determining the power coefficient (coefficient of wind energy utilization) C_P for a particular operating mode - wind speed, tip speed ratio λ and rotation speed. Choosing a wing profile is also part of this process. The main dependencies and sequence of calculations are as given in [20] and are shown in short as follows:

- the blade is represented as a finite number of sections, spaced equally across the span;
- the TSR is determined for each section as a function of the current radius r :

$$\lambda_r = (\omega r)/v \quad (21)$$

- the optimum relative wind angles $\varphi_{r,opt}$ of apparent wind (wind angles) are calculated (this is the flow angle which the effective flow velocity of a given section of the blade makes with the plane of rotation of that blade). These angles are determined according to [20,21] by formula (22) to achieve the maximum value of the power factor (Fig.2)

$$\varphi_{r,opt} = (2/3) \tan^{-1}(1/\lambda_r) \quad (22)$$

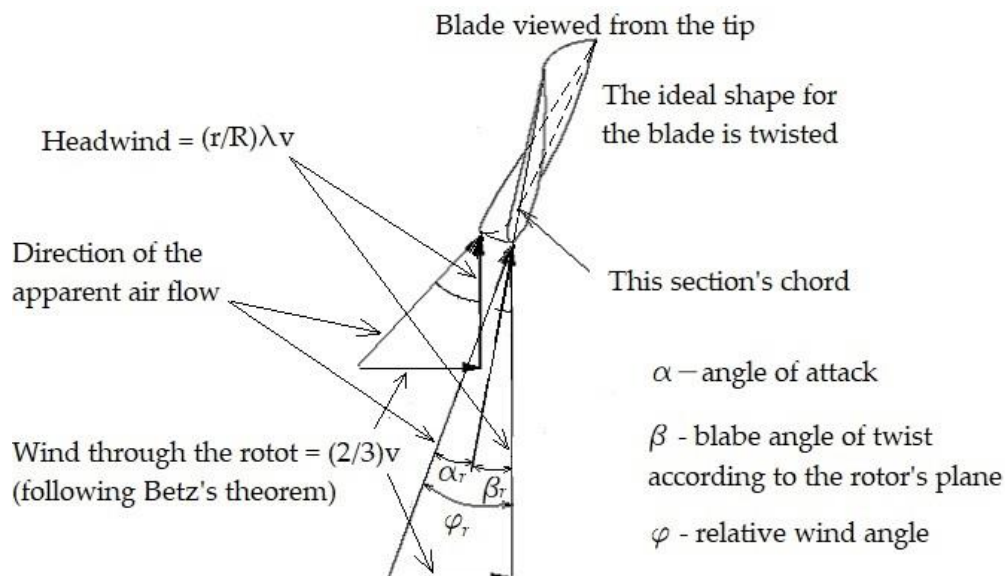

Fig. 2. Section angles – angle of attack, blade angle, relative wind angle.

- the tip loss factor is calculated for each considered section of the blade;

$$F_r = (2/\pi) \cos^{-1} \left\{ \exp \left[\frac{-(B/2)[1-r/R]}{(r/R) \sin \varphi_{r,opt}} \right] \right\} \quad (23)$$

This factor takes into account the change in the aerodynamic characteristics of the sections along the length of the blade. For approximate simplified calculations, $F_r = 1$ for $(r/R) < 0.97$ and $F_r = 0$ for $(r/R) \geq 0.97$ could be assumed.

- the distribution of the lengths of the chords along the length of the blade are determined, i.e. as a function of the radius r , by means of (24):

$$b_r = [8 \cdot \pi \cdot r \cdot F_r \cdot \sin \varphi_{r,opt} \cdot (\cos \varphi_{r,opt} - \lambda_r \cdot \sin \varphi_{r,opt})] / [B \cdot C_{yKmax} \cdot (\sin \varphi_{r,opt} + \lambda_r \cdot \cos \varphi_{r,opt})] \quad (24)$$

More roughly the the distribution of the lengths of the chords along the length of the blade could be determined by (25):

$$b_r = [16 \cdot \pi \cdot R \cdot (R/r)] / [9 \cdot \lambda^2 \cdot B] \quad (25)$$

- the distribution of the angles (so called blade angle) of twist of the chords along the length of the blade are determined by means of (26):

$$\beta_r = \varphi_{r,opt} - \alpha_{opt} \quad (26)$$

- the power coefficient is determined using a sum approximating the integral

$$C_p = \frac{8}{\lambda^2} \int_{\lambda_h}^{\lambda} F_r \sin^2 \varphi_{r,opt} (\cos \varphi_{r,opt} - \lambda_r \sin \varphi_{r,opt}) (\sin \varphi_{r,opt} + \lambda_r \cos \varphi_{r,opt}) \left(1 - \frac{1}{\operatorname{tg} \varphi_{r,opt} \cdot K_{max}} \right) \lambda_r^2 d\lambda_r$$

by means of (27):

$$C_p = \sum \left[\left(\frac{8(\lambda_r)^2 \cdot \Delta \lambda_r}{\lambda^2} \right) F_r \sin^2 \varphi_{r,opt} (\cos \varphi_{r,opt} - \lambda_r \sin \varphi_{r,opt}) (\sin \varphi_{r,opt} + \lambda_r \cos \varphi_{r,opt}) \left(1 - \frac{1}{\operatorname{tg} \varphi_{r,opt} \cdot K_{max}} \right) \right] \quad (27)$$

The calculation of the values of above parameters is performed for the profiled part of the blade along its length from $r/R = 0.2$ (accepted here) to $r/R = 1$. Here λ_h (in the integral showed above) denotes the tip speed ratio in the section closest to the hub of the turbine rotor. In formula (26) α_{opt} denotes the optimal angle of attack of the correspond section of the blade. When designing the blade, this angle must correspond to the most advantageous, i.e. at maximum aerodynamic quality K_{max} (ratio of lift coefficient to drag coefficient) for the relevant profile. In formula (24) the coefficient C_{yKmax} denotes the lift coefficient at which maximum aerodynamic quality is ensured. The most frequently used profiles are from the NACA 44XX, NACA 230XX, NACA 63-2XX series.

At the determined wind speed, turbine speed and propeller radius, sample calculations were performed to design the blade. The profile NACA 4412 was chosen for the profile with the following characteristics (Figure 3) – Reynolds number $R = 280000$, lift coefficient $C_y = 1.05$ at maximum quality K_{max} , maximum aerodynamic quality $K_{max} = 42$ and angle of attack at maximum quality $\alpha_{opt} = 6^\circ$ [22]. The distribution of chords is calculated by dependence (24). Figure 4 and Figure 5 present the results of the calculation of the angles of placement of the chords of the cross sections of the wind turbine blade and the lengths of the chords of the respective sections along the length of the blade, which was done using Microsoft Excel software.

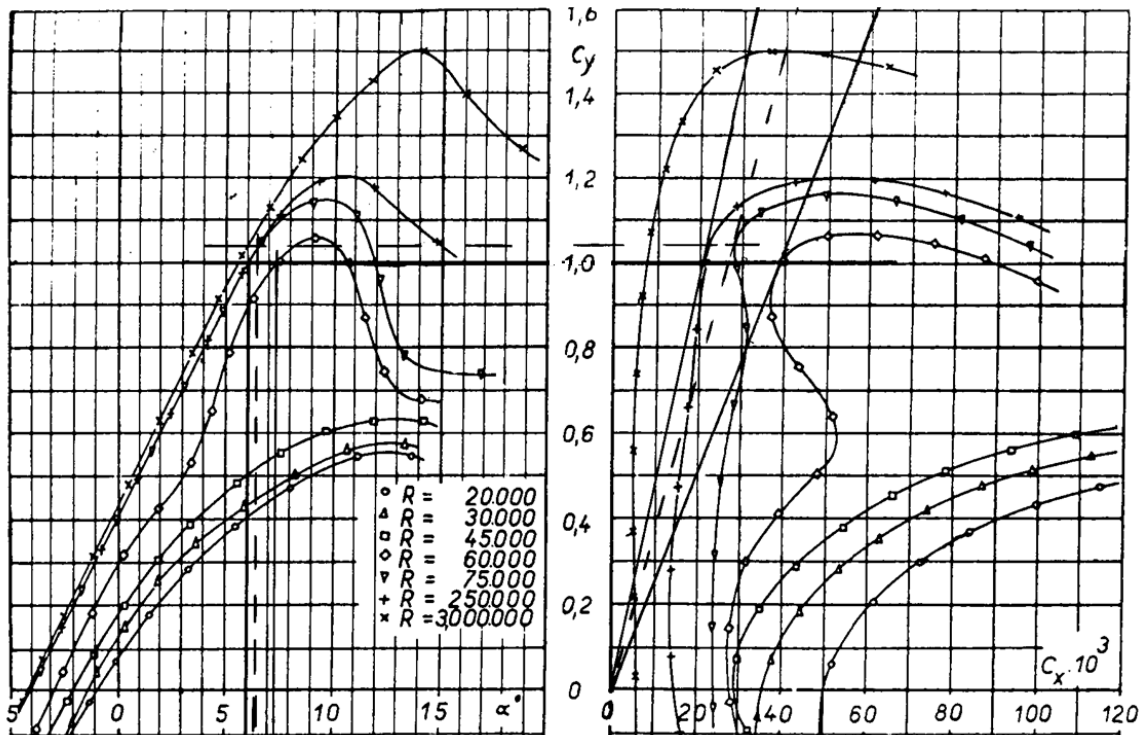

Fig. 3. Graphs - aerodynamics characteristics of airfoil NACA 4412 [22].

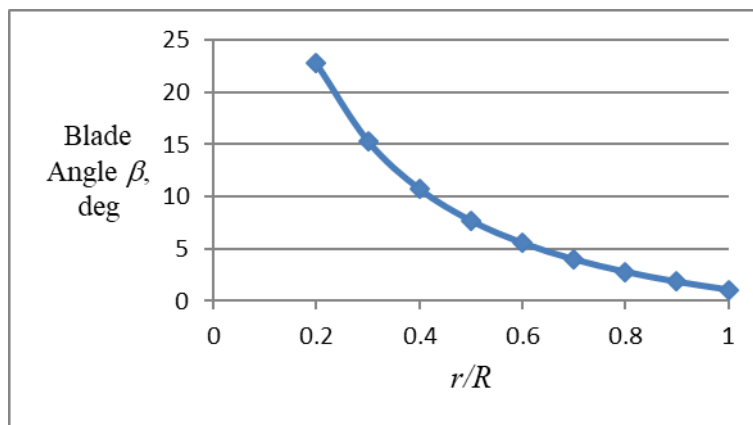

Fig. 4. Blade angle distribution of twist of blade sections profile of designed wind turbine rotor along the length of the blade.

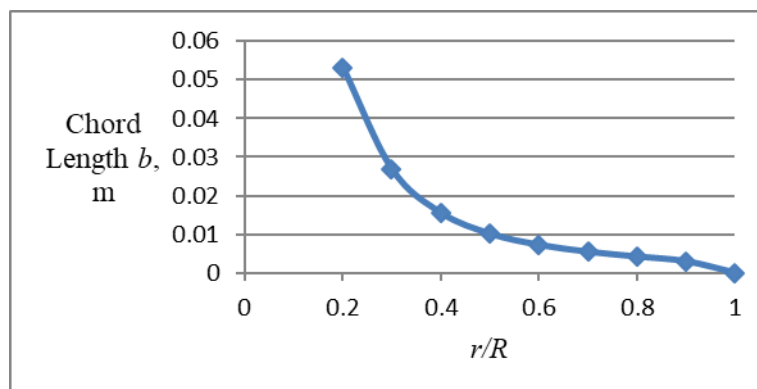

Fig. 5. Chord length distribution of blade sections of designed wind turbine rotor along the length of the blade.

Figure 6 shows the graph of the change of the power factor of the wind turbine at different modes of operation of the generator and at wind speed $v = 5.357 \text{ m/s}$

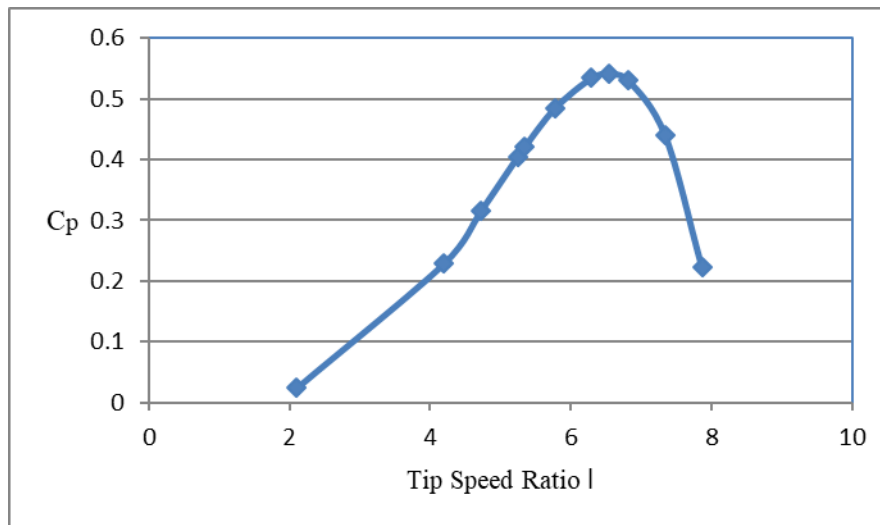

Fig. 6. Graph of the change of the power factor C_p of the wind turbine at different modes of operation of the electric generator and at wind speed $v = 5.357 \text{ m/s}$.

Figure 7 shows the change of the power of the designed wind propeller at different operating modes and wind speeds and comparison of powers at joint work with the alternator 145STK2M [23]. To match the operation of the wind turbine with the alternator, a multiplier with a gear ratio $i = 0.6211$ is placed between them.

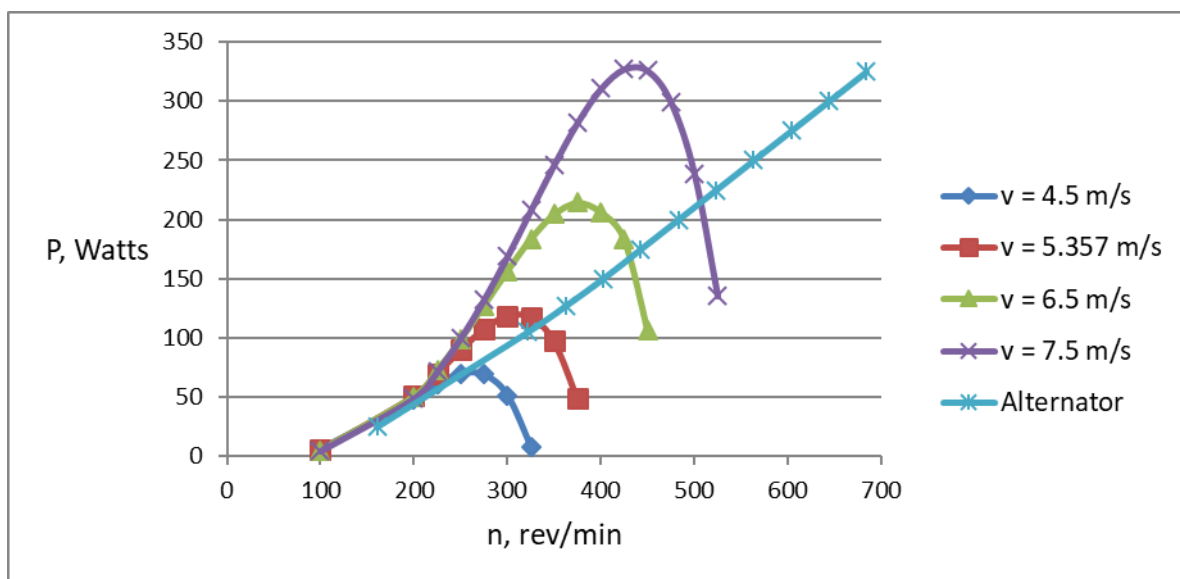

Fig. 7. Comparison of the wind turbine power at different wind speeds and in cooperation with the alternator GL - PMG - 1000 [23].

CONCLUSION

A sequence of structural calculations for low power wind turbine with fixed type blades on the wind propeller is presented. It is applicable for determining some basic parameters such as power output, wind turbine radius, number of blades, blade profiling, etc. and to match the operation of the propeller-multiplier-generator system.

REFERENCES

- [1] Петров Д., Пенчев С.: Последователност на предварителните конструкторски изчисления за ветрогенератор с малка мощност, Научни трудове на Съюза на Учените в България – Пловдив, Серия В Техника и технологии – Том VII, ISSN 1311 – 9419, стр.41-47, Пловдив, 2009 г.
- [2] Internet source: Бойко Е.В., Альтернативна енергия: Мощност ветроустановки, website: sam-stroy.info/vetryak/vetroust.htm.
- [3] Internet source: Продукти-Стартерни батерии-Търговски и тежкотоварни автомобили-SMF, website: <https://www.monbat.com/monbat/en/pages/premium-smf.html>
- [4] Katić V.A., Dumnić B.P., Katić N.A., Milićević D.M., Grabić S.U.: Potentials and market prospects of wind energy in Vojvodina, Thermal science, Year 2012, Vol.16, Suppl.1
- [5] Đorđević T., The possibilities for using wind energy in AP Vojvodina (North Serbia) – Defining the most favorable areas for the construction of windmill farms: A Review, DOI: 10.18421/GP20.01-05, ISSN 0354-8724 (hard copy) | ISSN 1820-7138 (online)
- [6] Stipić Z., Vidović S., Spasojević M.: Potentials of renewable energy sources in the republic of Serbia with a detailed review of the exploitation of geothermal resources in the autonomous province of Vojvodina, Available at website: https://geothermalcommunities.eu/assets/elearning/1.41.CLANAK%20KOMPLET_ENG.pdf
- [7] Wei Tong: Fundamentals of wind energy, Chapter 1, Wind Power Generation and Wind Turbine Design, WIT Transactions on State of the Art in Science and Engineering, Vol 44, © 2010 WIT Press, ISSN 1755-8336 (on-line)
- [8] Website: <https://en.wikipedia.org/wiki/Density>
- [9] Website: https://www.skybrary.aero/index.php/Density_Altitude
- [10] Website: https://en.wikipedia.org/wiki/Atmospheric_temperature/
- [11] Website: <https://vmh-bg.com/%D1%80%D0%B0%D0%B7%D0%BF%D1%80%D0%B5%D0%B4%D0%B5%D0%BB%D0%B5%D0%BD%D0%B8%D0%B5-%D0%BD%D0%B0-%D1%82%D0%B5%D0%BC%D0%BF%D0%B5%D1%80%D0%B0%D1%82%D1%83%D1%80%D0%B0%D1%82%D0%B0>
- [12] Фатеев Е.М.: Ветродвижатели и ветроустановки, ОГИЗ-СЕЛЪХОЗГИЗ, Москва, 1948 г., стр.15.
- [13] Wei Tong: Wind Power Generation and Wind Turbine Design, WIT Press ,25 Bridge Street, Billerica, MA 01821, USA, ISBN: 978-1-84564-205-1, 2010.
- [14] Иванов П.: Практическо използване на вятъра в България за производство на електроенергия, Available at website: http://www.energy21-bg.net/files/4_Ivanov_PracticalUse-BGWindEnergy.pdf
- [15] Somerton C. W.: course “Design of Alternative Energy Systems”, Wind Energy Calculations, Available at website: <http://www.egr.msu.edu/classes/me491/benard/WindCalc.pdf>
- [16] Бойко Е.В.: "Как соорудить самодельную ветроустановку", website: <http://sam-stroy.info/vetryak/veter.htm>
- [17] Бойко Е.В.: "Как соорудить самодельную ветроустановку", website: <http://sam-stroy.info/vetryak/vetrocoleso.htm>
- [18] Ульрих Хюттер: Философия конструирования ветроустановок, website: <http://www.vetryaky.ru/statya-haynera-dyornera/>
- [19] Website: <http://www.ginlong.com/wind-turbine-pmg-pma-permanent-magnet-generator-alternator-GL-PMG-1000.htm>
- [20] Serhat Duran.: Computer-Aided Design Of Horizontal-Axis Wind Turbine Blades, A Thesis Submitted To The Graduate School Of Natural And Applied Sciences Of Middle East Technical University In Partial Fulfillment Of The Requirements For The Degree Of Master Of Science In Mechanical Engineering, January 2005
- [21] Mario Alejandro Rosato: Small Wind Turbines for Electricity and Irrigation - Design and Construction, CRC Press - Taylor & Francis Group LLC, 2019, ISBN-13: 978-1-138-57022-1 (Hardback), ISBN-13: 978-1-138-57019-1 (Paperback)

- [22] Hugh Piggott: Small Wind Turbine Blade Design Notes, website:
<http://www.scoraigwind.com/wpNotes/bladeDesign.pdf> , 2020.
- [23] Website: <http://www.alxion.com/wp-content/uploads/2011/10/145ATK2M.pdf>

EUROPEAN ONGOING INITIATIVES FOR TRANSFORMING COVID-19 CRISIS INTO AN OPPORTUNITY FOR A SUSTAINABLE FUTURE

Kaja Primorac¹, Lucija Kolar², Anja Bubik³, Daniela Tulone⁴

¹weTHINK Institute - The Social Network for Strategy, Austria

²Complementarium, Institute for research of nature and development of environmental technologies Lopata, Slovenia

³Environmental Protection College Velenje, Slovenia

⁴ecoSurge <https://www.ecosurge.org/restartogether>, Italy

e-mail address: kaja.primorac@wethink.eu, lucija@complementarium.si,
anja.bubik@vsvo.si, contact@danielatulone.com

Abstract: The impact of the COVID-19 pandemic is unprecedented, with over a million deaths and several millions people affected by it worldwide causing a remarkable social, political and economic shock. We face historical challenges that cannot be addressed without a renewed effort for an active cooperation at governmental, business, institutional, and academic level. The challenges we face also demand a mindset shift that places people and cooperation values at the center of our aspirations. Yet, the crisis is also enriching humankind with an opportunity to redesign our ways, and build a more sustainable, resilient, and humane future. In this paper we present three initiatives and an academic good practice sharing similar focus by showing the evidence of the power of cooperation in building a better and more powerful, built together synergistic social community.

Key words: sustainability, 2030 Agenda, sustainable development goals (SDGs), initiatives, COVID-19, synergy

INTRODUCTION

In 2015 the United Nations' unanimously adopted 2030 Agenda for Sustainable Development recognised the importance of transforming societies through sustainable, resilient, and inclusive paths that encompass the interlinked and universal Sustainable Development Goals (SDGs) [1]. The 17 SDGs and its 169 targets aim to promote a global agenda for sustainable development to be achieved by 2030. The perfect storm of social, economic and health disasters caused by the COVID-19 pandemics, directly threatens the world's livelihood and wellbeing, and can, therefore, further delay the achievement of the United Nations Sustainable Development Goals (SDGs) [2].

The World Health Organization (WHO) officially declared COVID-19 a pandemic on March 11, 2020 [3], and by 15 May over 3.4 millions confirmed cases were reported [4]. Measures to recover from the present crisis are virtually certain to include long-term investments in health, energy, water, transport, and other critical infrastructure [5]. Climate-aware individuals and institutions recognize the present crisis as an opportunity - indeed an imperative - for resilient, carbon-neutral and equitable structural change. Certainly COVID-19 has dramatically reshaped the policy-making debate by: 1) bolstering public authority over private agency, 2) elevating collaborative planning over reliance on price signals, 3) expanding the scope of all-hazard resilience to emphasize pandemic risks, and 4) vastly increasing public awareness of the need for holistic resilience [6]. However, all this is not possible if there will not be an "overall mindset shift", in which the whole society will be included by starting to think more inclusively and less individually.

We are given the opportunity to learn from the current pandemic to redefine our objectives and strategies to effectively achieve them. The times we are currently facing demand new thought-patterns and values, rapid adaptation, and immediate action. We are given the opportunity to co-create our present and future. For effectively doing so, the main components of a new sustainable, social and resilient mindset must be determined, as working on the "mindset" open questions and disseminating the answers shall be the key to success. For that, all individual and collective aspects, essential for the re-launch, and the priorities must be thoroughly examined, and thoughtfully integrated in this so-called mindset shift.

We believe that co-creation initiatives and cross-sectoral cooperation play a key role in facing complex challenges of our world, and creating new business and social models that regard human beings and the environment as the primary resource for the societal re-launch. Circular economy, digitalization, technological and business innovation are essential components to realize the targets of sustainable transformation.

In this paper, different initiatives - launched during the pandemic and developed in different communities and countries (Austria, Italy and Slovenia) that share such perspective - are illustrated. They are not only an example of successful initiatives focused on the re-launch through the SDGs, but also provide evidence of the effectiveness of cross-initiatives and cross-sectoral collaborations, stemming from the field work.

In the following section the three initiatives, and a best practice developed at the Environmental Protection College in Velenje, are illustrated more in detail. More specifically, we present a global online think-tank called Restart Together, focused on business and digital innovation to support the re-launch of businesses (1), a think-tank, called weTHINK, focused on policy-making and strategy-development in Southeastern Europe (2), and a Slovenian interdisciplinary initiative, called Kooperativa to support local businesses (3). We conclude the paper by highlighting on-going collaborations among these initiatives and showing the evidence of the effectiveness of international cross-sectoral collaboration, which represents the core of the SDG 17 on partnerships for development.

EUROPEAN SUCCESS CASES ON COOPERATION TOWARDS AGENDA 2030

Global initiative of an Italian origin



Restart Together (www.ecosurge.org/restarttogether) is an initiative to support the relaunch of businesses in the pandemic through UN SDGs. It is promoted by ecoSurge (www.ecosurge.org), a global initiative that focuses on the design of innovative solutions to today's problems built on top of advanced digital technologies and innovative business models to move faster in the implementation of the UN SDGs.

Active international cooperation across businesses, institutions, academia, and no-profits is central to ecoSurge activities and regarded as an essential tool to tackle today's complex challenges and scale-up successful sustainable solutions. As the pandemic is deeply changing our society, the way of doing business and relating to each other as individuals and communities, it is very important to analyze the impact of those changes, learn from them, and work towards a mindset shift to efficiently redesign our future. We believe that diversities in background, viewpoint, and culture, can strengthen this process and help highlight pitfalls and opportunities more rapidly.

Restart Together is a project started during the Italian lockdown from the desire to transform the sanitary emergency into an opportunity to fix current limitations in our economic and social systems, and relaunch the sustainability transformation. It is a virtual think-tank, a network of professionals, entrepreneurs, researchers, SMEs, innovation labs sharing their expertise and insights, and fostering idea generation in line with the UN SDGs to support the relaunch of businesses. Restart Together offers an active forum to share insights on key aspects for the relaunch of businesses and sustainability, such as the mindset shift, the new role of digital technologies and circular economy, new businesses models and more effective leadership styles.

We are a community of professionals, entrepreneurs, innovators, researchers, SMEs, innovation labs from different countries and fields who believe in the power of innovation and active cooperation, which is the SDG17 target, and in the urgency to make our social, economic, and political systems

more sustainable, resilient, and human. In addition to that together with partners we organize activities such as webinars with success business cases to inspire and encourage entrepreneurs in this hard time. Participants benefit from joining an international dynamic and innovative ecosystem with professionals eager to collaborate and explore new business ideas (e.g., funding projects, joint products, scale-up of sustainable products/services or market expansion). Moreover, through Restart Together participants have the opportunity to expand their internal resources through an interdisciplinary network of first-class innovators, entrepreneurs, researchers engaged in sustainability from all over the world and learn from each others' experiences, success cases, and best practices. In addition, it offers participants the opportunity not only to connect but to grow through webinars and on-line workshops, which are organized with our partners.

A valuable partner is weThink that allows us to integrate our business and technological competences with a focus on policy-making and institutions in South-East Europe, and grow opportunities. With Ko-operativa we exchange specific knowledge, e.g. environmental sustainability, where, together with Environmental Protection College we try to educate and empower.

A common initiative of Southeastern European countries “weBuildBackSmart”, led by the Austrian think-tank weTHINK



It has now become obvious that to foster a durable and resilient economic recovery after the COVID-19 crisis, much more than a return to ‘business as usual’ is required. As global environmental emergencies, such as climate change and biodiversity loss, if remained unchecked, could cause social and economic damages far larger than those caused by COVID-19, the environmentally destructive investment patterns and activities must be avoided. To eliminate the reproduction of such societal behaviours, weTHINK has designed a BuildBackSmart initiative, encompassing three key principles for smart-community-building:

- **Sustainability** – connecting the economic, social and environmental dimensions, the sustainability paradigm should become the key ingredient of each policy-making process by 2030. The essence of the latter has also been captured in the European Green Deal with the overarching aim of making Europe climate neutral by 2050.
- **Digitalisation** – as the Digital Europe Vision 2025 strives to provide Europe’s people with competitive jobs, better health and better public services, the important objective of digitalisation is also assisting in fostering green growth, innovation and inclusion.
- **Inclusivity** – a cornerstone of every bottom-up initiative and an essential, but unfortunately many times left out, concept for a credible policy-making nowadays. It is undeniable that in order for policies to be effective and efficient, multiple voices of different groups of society must be reflected in the latter.

Yet, the initiative aims at more than getting economies and livelihoods quickly back on their feet. The main objectives of the initiative could be summed up as three individual, but mutually intertwined pillars:

1. **Building an inclusive multi-stakeholder community, by using an innovative strategy-making approach**, including all relevant stakeholders and considering every single opinion-maker participating (bottom-up approach), to be able to create a **strong network**, and later form consortiums and **respond to the new realities together**, by applying to the European Green Deal related funding within the Multiannual Financial Framework 2021-2027;
2. **Facilitating an in-depth dialogue** on the topics of sustainability, digitalization and smart solutions **with different types of relevant stakeholders** (NGOs, think tanks, academia, policy-makers, social partners, business sector, youth and other interested individuals) in

Southeastern Europe, **in order to make a needs assessment** regarding sustainable development in the region;

3. **Prepare a Strategic Roadmap**, which will offer directions for the smart recovery of SEE on all levels of society, as it will be co-created with all types of stakeholders from the region. The document will also serve as a **cornerstone guidelines for the national and European stakeholders to be able to allocate the funding opportunities** to the topics that will most efficiently contribute to enhancing sustainability in the region.

Local Slovene initiative “Ko-operativa”



Ko-operativa was established during the lockdown in the second half of March 2020, as an informal gathering of persons who share similar philosophy in order to help and work in the local environment of the municipality of Celje, Slovenia. We are an autonomous association of persons voluntarily connected with the intention of responding to our shared economic, social and cultural needs and efforts through a community and we govern democratically. We are looking for solutions to local challenges by connecting entrepreneurs and people in need. Our reactions are still, due to the Covid-19 situation (as mentioned) strongly connected to the public needs, e.g.: collecting computers for local schools, shields for protection and plastic bands for masks for Celje hospital etc. Among us, we have various experts working in the field of legal counseling, proposal writing, computer programming which all (voluntarily) contribute to the people interested through consulting.

In Ko-operativa we strive to connect businesses, individuals, initiatives, projects, and events. All these with the intention and under the common denominator of co-creation of new social models and actions for the common good. We see our role in creating new models of business and life, especially in cooperation with nature, in sustainable forms of operation, with the model of circular economy and self-sufficiency, using digitization and the spirit of solidarity. We believe in the principle from local to global and expanding horizons across borders. We are ready to share good practices and we are looking for partners locally and internationally. We would like to cooperate with various business entities, governmental and nongovernmental organizations.

One of our main objectives is to exchange good practices on both sides and put them into practice in accordance with the values and objectives described above. On this behalf we also built an electronic platform, www.ko-operativa.com, where anyone who would like to share an initiative, knowledge or business proposition is welcome to register and become a member of the Ko-operativa community. The membership is free of charge and it is also meant as a support especially for young entrepreneurs as it offers kind of a free marketing with publicly available information which is also mapped accordingly to the address of the organization. The web page is currently available only in Slovene language, but the English translation is in phase of preparation.

The long term goal of Ko-operativa is global connectivity and supporting similar initiatives for more resilient society. Although fostering resilience requires a holistic and integrated approach to the SDGs this new adversity presented in the form of COVID-19 has created a public emergency that requires swift responses and changes. In the process of implementing the SDGs [7], it is essential that we understand the interactions among targets that require valuable interdisciplinary information and also support from the wholesome society.

High education challenges found in sustainable initiatives

One of the social areas that faced the strongest challenges during the Covid-19 era, without being really prepared for it, is that of education [8]. All stakeholders involved in education processes were suddenly put in a position to change their rules of operation, teaching techniques and concepts or examination methods. They must adapt to new technologies and assimilate to strongly altered conditions. All these changes together with differences in accessible and available resources had led to

worldwide racial, gender, regional and financial discriminations, especially in less developed regions. But pandemic generated not only significant risks, crisis, or costs, but also lifelong learning opportunities for all. Especially in correlation with the 2030 Agenda, where higher education plays a key role as a means to achieving Goal 4 on education: inclusive, equitable and quality education for all [9, 10]. Two specific factors were assessed by Owens as essential if higher education is to play a revitalized role in the sustainable development framework: publicly funded research and regional higher education partnerships [9].

At the Environmental Protection College Velenje, Slovenia we are aware of diverse educational consequences of pandemic, therefore we must focus our activities on mitigating as many negative outcomes and impacts, recognized or just expected in our environment. We are willing to offer equal educational opportunities to each student and deliver the same education quality as before the time of the Covid-19 era. Our mission of providing well educated and highly qualified teaching and research staff, who can confront all challenges in the field of environmental protection and new eco-technologies, is now even more on trial. We are aware that this is the only way we can contribute to sustainable management of the environment and its natural resources in the future. We would like to achieve our educational and research goals by many activities, like approximating the international standards in this profession, and by using modern teaching methods, research findings and practical work. Inspired by the Agenda 2030 and its SDGs, we are planning to enrich and strengthen activities like discussions, round tables, team and field work, and projects in today's crisis. We will be involved in professional public initiatives and more actively participate in the events, organized by initiatives targeting raising sustainable awareness. During the coming year, we will perform the survey on how students are familiar with the Agenda 2030 and its SDGs. All with the aim to bring students closer to SDGs, and to promote the opportunities, which are given to them by Agenda 2030 in hand with the Covid-19 era.

Today, our goals are the same, but the challenges are bigger. Our environmental awareness is strong, but it needs to be continuously complemented and empowered by all the worldwide established sustainable goals and ideas. We believe that by doing so students will be equipped with enormous knowledge, skills and competencies within personal and social related perspectives.

The coronavirus pandemic has shown once more the need for a rapid and sustainable transformation of our productive systems to make them more resilient, adaptable, and more focused on people's needs. Only together we will be able to respond to today's challenges due to a more uncertain and vulnerable society.

The presented cases show the possibility for building strength in co-creation and re-building system changes by working together and applying for different European funds (e.g. Horizon Europe) - the new perspective - Multiannual Financial Framework 2021-2027 Besides that all listed cases are examples of excellent collaborative work which enables expansion of the network, immediate exchange of opinions and added value in the sense of achieving actual results in terms of activation and sustainable solutions.

CONCLUSION

We believe that the 2030 Agenda can provide a framework for recovery and help with accelerating the response to, and recovery from, the pandemic. Therefore, (inter)national networks, forged by globalization and strengthened by the technological advances, enable greater knowledge transfer, which emphasize the importance of maintaining these networks active to share good practices and experiences. The experiences from presented initiatives - Restart Together, Ko-Operativa, weBuildBackSmart and a good practice of Environmental Protection College - show that all societies are being faced with similar systemic problems and as well fears on how to overcome the situation in this era of Anthropocene. Moreover, they serve as examples of synergistic collaborations, in which the main protagonists are people and their need for active participation, addressing especially SDGs 16 and 17.

Zabaniotou [7] in her paper explores various frameworks that are contributing to the transdisciplinary meta-perspective of resilience. Moreover, it proposes a humanistic approach based on not only controlling strategies involving containment and social isolation, but also the ecological balance considering the human, societal, and ecological health as a system-wide emergent property.

Conceptual frameworks of resilience are discussed focusing on the role of leadership and empowerment. She also gives an in-depth review on types of resilience and intelligences, which are of major importance in this “new” society, full of unpredictable situations, even in our personal lives. The author considered societal and individuals’ resilience as functions of the social-ecological systems that is, a system of people and their environments with complex interactions [7]. All this shows that society needs alternatives in response to the current situation and it should be built on the process of collaboration and long-term sustainability. In another paper [6] the case of Japan is presented, and we found it as a good example of showing how situation can be improved by building national resilience plans and what are the good outcomes of it.

This was as well observed in cases of our collaboration where Slovene initiators connected with Italian initiative (and vice-versa) and already actively participated in the Austrian WeThink first workshop (on how to build a smart future for southeastern Europe) out of four planned. We are now together seeking new ways of collaboration and success stories as this is the only way for stronger and better synergies and joint positive results in COVID-19 era.

Global partnerships are critical to formulating and disseminating a global response. That is why goal 17 of the SDGs centres on strengthening global partnerships among national governments, the international community, civil society, the private sector and other stakeholders. The 2030 Agenda thus embodies the shared responsibility and global solidarity essential to making COVID-19 recovery a major step in the long journey back from planetary boundaries and towards sustainable and resilient communities.

Future studies should focus on COVID-19 social impacts, observing its trends and long-term effects on our society in everyday life. Proper mapping of existing initiatives and good practices should help improving the resilience of our socioeconomic systems and its relations to business and society leading to a more prosperous era.

REFERENCES

- [1] United Nations (UN), Written inputs to the UN high-level political forum on sustainable development (HLPF): Sustainable, resilient and inclusive societies, The path towards transformation, New York, pp. 9-18, 2018.
- [2] Zhou, C., Su, F., Pei, T., Zhang, A., Du, Y., Luo, B., ... Xiao, H., COVID-19: Challenges to GIS with big data, *Geography and Sustainability*, pp. 77-87, 2020.
- [3] Internet Source: World Health Organization (WHO), WHO Director-General’s Opening Remarks at the Media Briefing on COVID- 19 - 11 March 2020: <https://www.who.int/dg/speeches>.
- [4] Internet Source: World Health Organization (WHO), COVID-19 Situation Reports, 2020: <https://www.who.int/emergencies/diseases/novel-coronavirus-2019/situation-reports>.
- [5] Lu, J., A simple way to close the multi-trillion-dollar infrastructure financing gap, 15 April, the World Bank, 2020.
- [6] DeWit, A., Shaw, R., Djalante, R. An integrated approach to sustainable development, national resilience, and COVID-19 responses: The case of Japan, *International Journal of Disaster Risk Reduction*, pp. 1-6, 2020.
- [7] Zabaniotou, A., A systemic approach to resilience and ecological sustainability during the COVID-19 pandemic: Human, societal, and ecological health as a system-wide emergent property in the Anthropocene, *Global Transitions*, pp.116-1262, 2020.
- [8] Corlatean, T., Risks, discrimination, and opportunities for education during the times of COVID-19 pandemic, RAIS (Research Association for Interdisciplinary Studies) Conference Proceedings, pp. 37-46, 2020.
- [9] Owens, T.L., Higher education in the sustainable development goals framework, *Eur J Educ.*, pp. 1–7, 2017.
- [10] Internet Source: The 2030 Agenda for Sustainable Development, Sustainable Development Goals (SDGs), United Nations, New York, 2015: <https://sustainabledevelopment.un.org/?menu=1300>.